

Instructions - Radius Arm Bushings

N.B: This instruction sheet should be used in conjunction with the workshop manual and proper safety procedures followed.

Application: BMW - F20 Series
F30 Series
F80 Series

Contents: 2x bushings
2x offset steel tubes
1x grease

1. Raise vehicle and safely support. Remove front wheels.
2. Un bolt radius arm mounting bolt and ball joint and remove arms.
3. Press/push out worn bushings, careful to safely support and not damage the aluminium arms.
4. Press new bushings in arm - this is best achieved with soapy water.

**Note bushing flange thickness - the thinner flange is to accommodate the adjusting hex.
Press bushing in arm to best suit adjustment access on vehicle.**

5. Lubricate bushing ID and face with the supplied grease and push the supplied tubes in position.
6. Tighten all bolts and carry out wheel alignment - note image below for adjustment reference.
7. Re check after initial 100kms

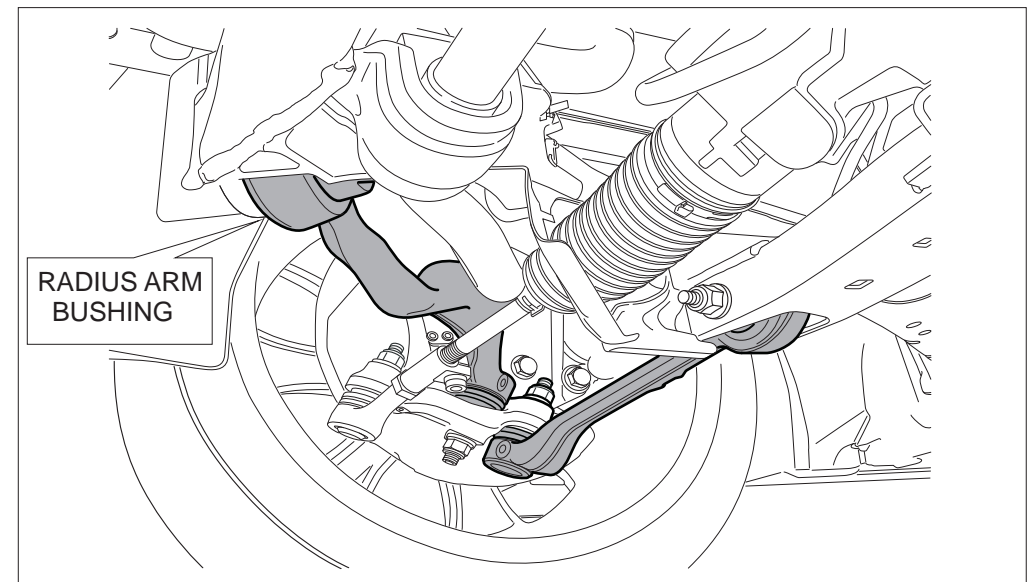
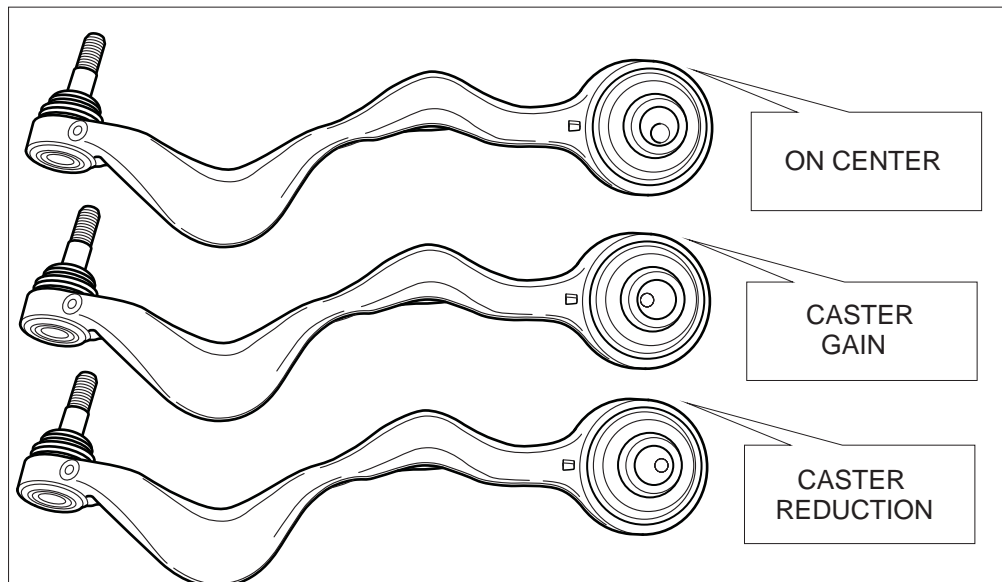

N.B: It is recommended that a licenced workshop or tradesperson carry out the above procedure and that workshop manual and relevant safety procedures are followed in addition to the above.