

Alloy Lateral Lock Kit

Alloy Lateral Locks are designed to centralize your swaybar during operation

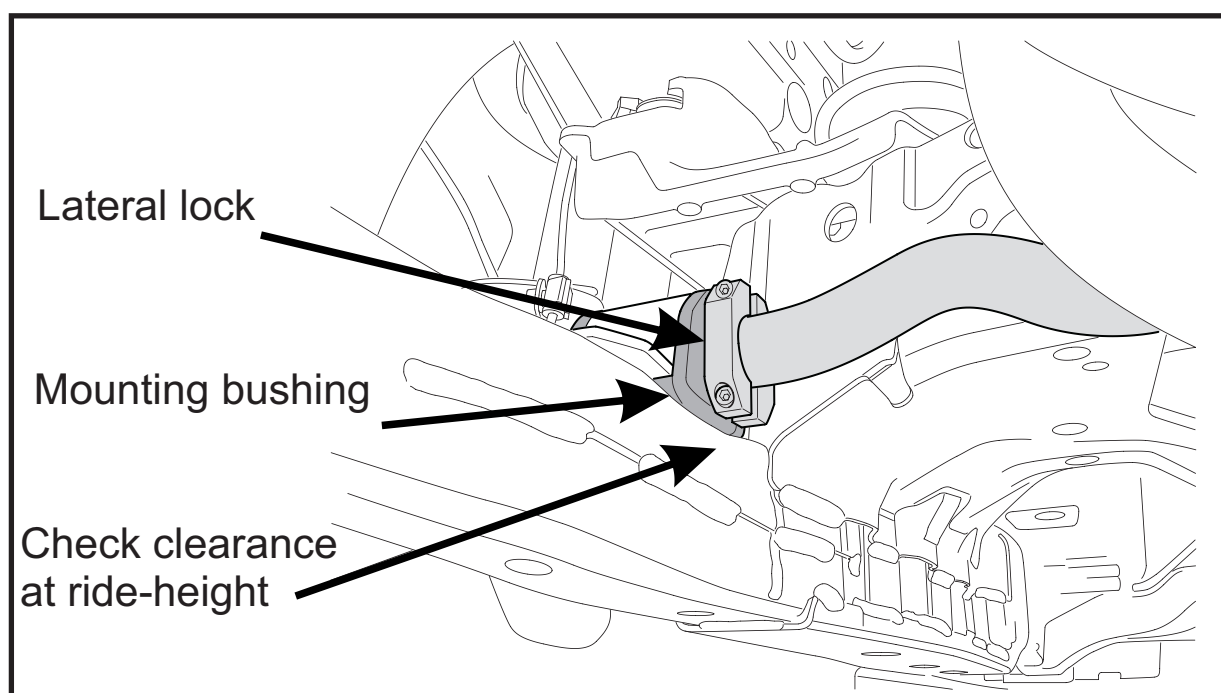

Confirm your Swaybar is central with links attached - this is best performed at ride-height.

Loosely bolt Lateral Locks next to the mounting bushing (leave approx 3-4mm gap). This can be either side of the mounting bushing but must maintain that both locks are fitted to identical positions LH and RH sides (both outside or both inside).

Check for clearance on full droop and full bump - the rotation of the lateral lock along the axis of the bar may foul other suspension components during rotation.

Tighten the Lateral Lock bolts down evenly and use mild force to secure. Careful to not over tighten.

Re-check Lateral Lock position after initial 100kms travelled.

GREASE FREE TECHNOLOGY



Introducing Grease Free Technology Bushings

Bushings supplied in this kit feature not only the latest synthetic elastomer bushing material technology but a high performing PTFE inner lining boasting an extraordinary low coefficient of friction. This inner lining eliminates the need to lubricate the bushing on installation and therefore makes these bushing 'grease free'!

Superior friction management

- reduces heat build up known to deform or degrade bushing over time
- dramatically reduces high frequency noises (squeaking)
- eliminates the need for maintenance/ greasing

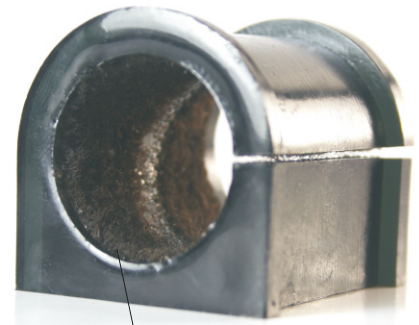

PTFE LINING

Installation tip

Ensure a clean mating surface when installing these bushings for optimum performance!

Frequently Asked Questions

What happens if I do apply grease to the lining?

Don't stress, simply wipe away as much of the lubricant from the surface as possible and install. Adding grease does not further improve the bushings function/ performance nor does traces of lubricant impede the function/ performance.

Do I need to grease other areas of the bushing?

Simply, no! Unless the kit is supplied with a grease packet and lubrication instructions, no other area of the bushing requires lubrication.

Do these bushings require maintenance?

Significant improvements in grease retention within bushing design has dramatically improved over recent years, however this new grease free technology does away with all lubricants and subsequent or periodical maintenance.

Is this technology available across the entire range?

For the most up to date offering of grease free technology bushings visit the website!

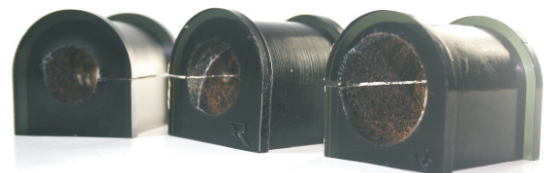
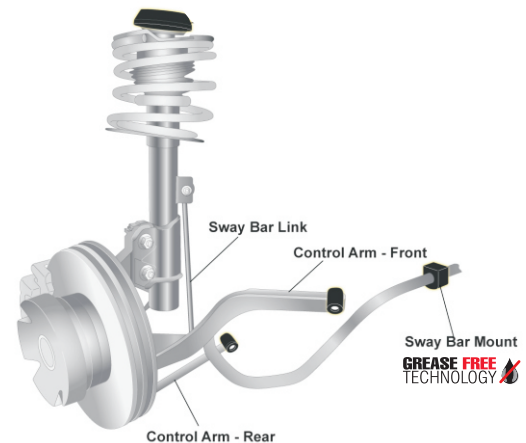

FRICION FREE | SILENT OPERATION | MAINTENANCE FREE

INSTALLATION GUIDE

Heavy Duty Front Swaybar

Application: - VW Golf Mk7
- AUDI Mk3

Contents: 2x mounting bushings
2x aluminium plates
2x steel brackets
4x M8 flange mounting bolts
4x flange nyloc nuts
1x 24mm adj. swaybar

Instructions

1. Raise vehicle evenly and safely support.
2. Disconnect the swaybar links.
3. Un-bolt the steering rack and swaybar mounting brackets from the sub-frame.
4. Support the sub-frame and start to un-bolt - lower the frame down enough to access and remove the swaybar.
5. Use supplied aluminium plate and steel saddle to mount the swaybar.

IMPORTANT - aluminium plate

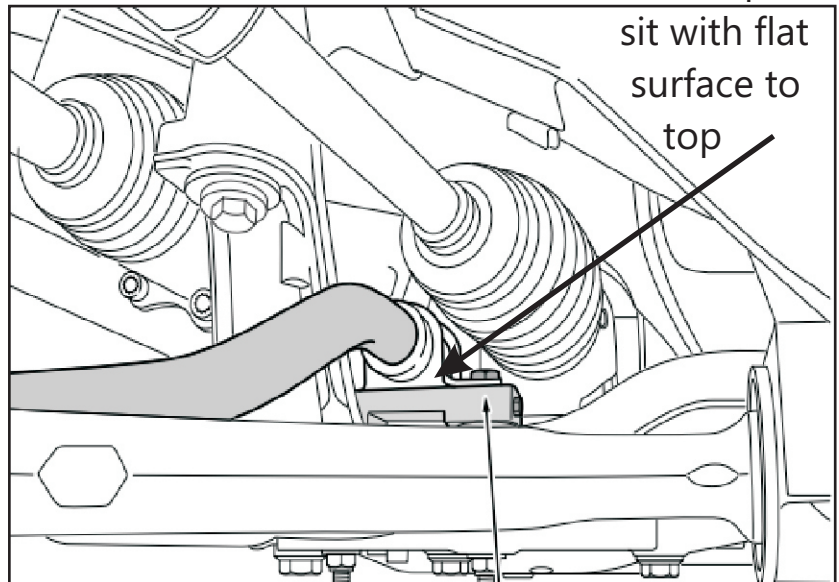

NOTE: Place aluminium plate as per top image. Place supplied bolts in position with bolt head up top

6. Confirm swaybar is central and fit up the supplied lateral locks.
7. Bolt up sub-frame and swaybar links and carry out a wheel alignment.
8. Re-check all bolts after 100kms travelled.



Warning: Please drive carefully while you accustom yourself to the changed vehicle behaviour.