

**UT1001 & UT2001**  
**UNIVERSAL T-PIPE KIT - ALL FULL SIZE**  
**PICKUP BEDS**

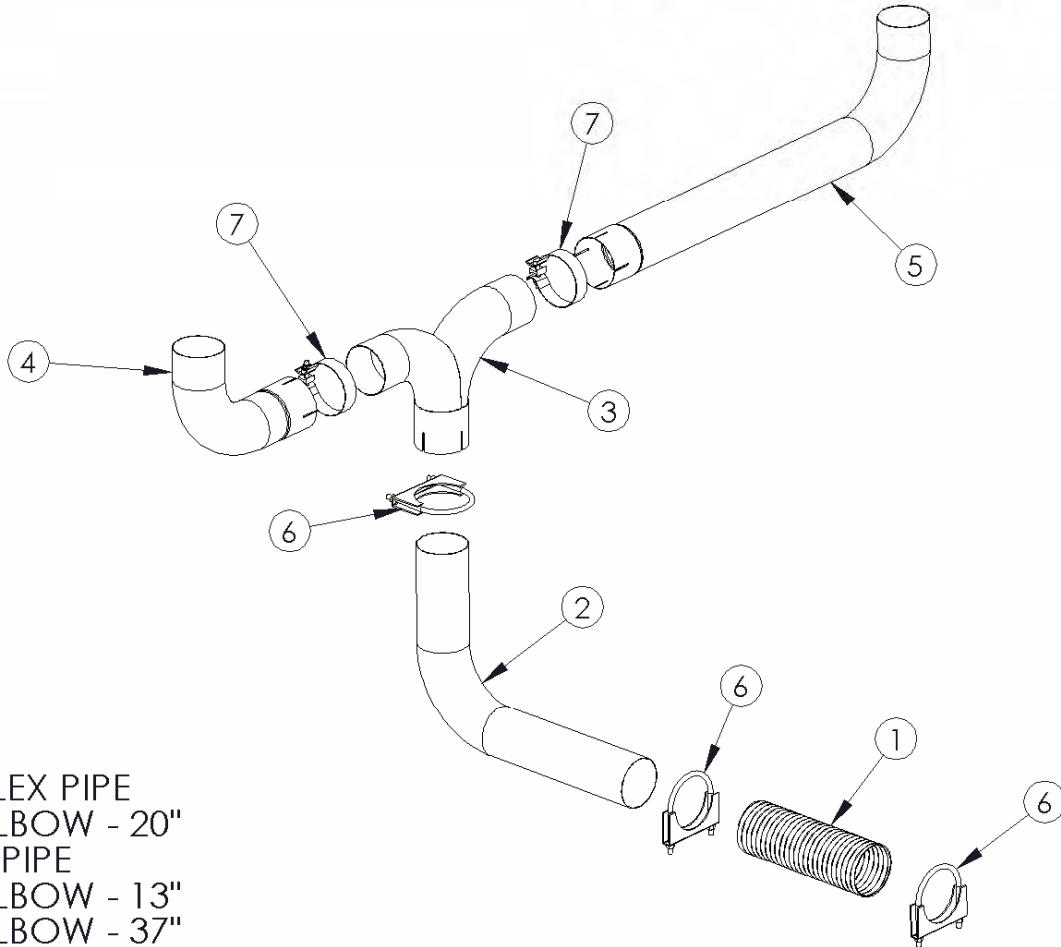

1. FLEX PIPE
2. ELBOW - 20"
3. T-PIPE
4. ELBOW - 13"
5. ELBOW - 37"
6. 4" CLAMP (3 PCS)
7. 4" BAND CLAMP (2 PCS)

NOTE: STACKS AND STACK MOUNTING BRACKETS SOLD SEPARATELY (NOT SHOWN)

**PLEASE READ BEFORE STARTING INSTALLATION**

**While MBRP Inc. has made every effort to ensure that all components of this system are of superior quality and properly packaged it is the installer's responsibility to ensure the following before removal of the factory exhaust:**

- that ALL components shown above are present.
- that ALL mating components fit together.
- that there are no damaged components.
- that the system you have purchased is appropriate for your vehicle year, model and configuration.
- that the system will not interfere with any modifications previously installed or planned.
- that you have read and understand these instructions.

If you have any questions or are uncertain about any aspect of the installation of this system to your vehicle please contact your dealer before commencing installation.

## Installation of MBRP Inc. "Smokers™"



Figure 1



Figure 2



Figure 3



Figure 4

1. Loosely assemble the in bed portion of the **T-Pipe Assembly (T-Pipe, 13" Elbow and 37" Elbow)**. Some models may require trimming of the **T-Pipe** in order to accommodate the width of the truck bed and the **Stacks** that have been purchased. Be sure to place the clamps over the pieces before they are assembled.
2. Place the **Stacks** onto the **T-Pipe Assembly** and place into the desired position in the truck bed. The **37" Elbow** should be on the driver side so that the **T-Pipe** passes through the bed floor towards the passenger side. **Refer to Figure 1.**
3. Place the **Stack Mounting Brackets** between each **Stack** and the front of the truck bed so that the **Stacks** are properly spaced from the front of the truck bed. Center the **Stack Mounting Brackets** on the **Stacks** and mark the front of the truck bed in the center of the slotted holes in the **Stack Mounting Brackets**. Center punch the marks and drill holes to accommodate a **3/8" Bolt** (included with the **Stack Mounting Brackets**). **Refer to Figure 2.**
4. Loosely attach the **Stack Mounting Brackets** to the front of the truck bed using the **3/8"** hardware supplied. Set the **Stacks** up in the bed and loosely attach them to the **Stack Mounting Brackets**. Make sure the **Stacks** are in the desired position and the **T-Pipe Assembly** is level.
5. Mark the bed floor where the **T-Pipe** is resting. MBRP Inc. recommends tracing around where the **T-Pipe** meets the bed floor. **Refer to Figure 3.** Remove the **Stacks** and **T-Pipe Assembly** from the bed of the truck. Find the center of the circle traced onto the bed floor, mark and center punch it. Go under the vehicle and locate the center punch mark. This marks the location where you are going to cut a hole for the **T-Pipe** to pass through the bed of the truck. If you cannot find the center punch mark use a small drill to create a pilot hole. Make sure that there is clearance for the **20" Elbow** to pass by any frame cross members. Remove or modify any heat shields that may cause interference.
6. Cut a hole through the truck bed providing adequate clearance around the part of the **T-Pipe** that passes through the truck bed. MBRP Inc. recommends using a **5" diameter hole saw**. It may be required to cut part of a bed rail away. **Refer to Figure 4.**



Figure 5



7. Set the **T-Pipe Assembly** at the desired height from the floor of the bed (This will set the height of the **Stacks**). Using spacers to hold the **T-Pipe** at the desired height, loosely attach the **Stacks** to the **Stack Mounting Brackets** making sure that they are straight. This will hold the assembly steady while you line the system up to the exhaust under the vehicle. **Refer to Figure 5.**



Figure 6

8. Measure from the **T-Pipe** slip joint to the exhaust system that you are connecting to. Mark and cut the shorter side of the **20" Elbow** to the required length so that it lines up with the vehicle's exhaust system. Cut the vehicle's exhaust system in a place where the **Flex Pipe** can be placed between the exhaust system and the **20" Elbow**. It may be necessary to cut the **20" Elbow** again as well as cut the **Flex Pipe**. **Refer to Figure 6.**



Figure 7

9. Attach the **20" Elbow** to the **T-Pipe** slip joint and then attach the **Flex Pipe** to both the **20" Elbow** and the vehicle's exhaust system. Be sure to slide the required **Clamps** over the **20" Elbow** and **Flex Pipe** before connecting it to the vehicle's exhaust system. **Refer to Figure 7.**

10. Make sure that the **Stack Mounting Brackets** are centered on the **Stacks** and tighten the fasteners holding the **Stack Mounting Brackets** to the front of the truck bed. Tighten all the **Clamps** making sure that the **Stacks** remains properly aligned.



Shown with 6" x 36" Stacks (B1610)

**Congratulations!** You are ready to begin experiencing the improved power, sound and driving excitement of your MBRP Inc. *"Smokers™"*. We are certain you will enjoy your purchase.