

# S3900

2012-2021 FERRARI 812SF 812GTS F12,  
6.5L V12, X PIPE KIT, 70mm

# MBRP®

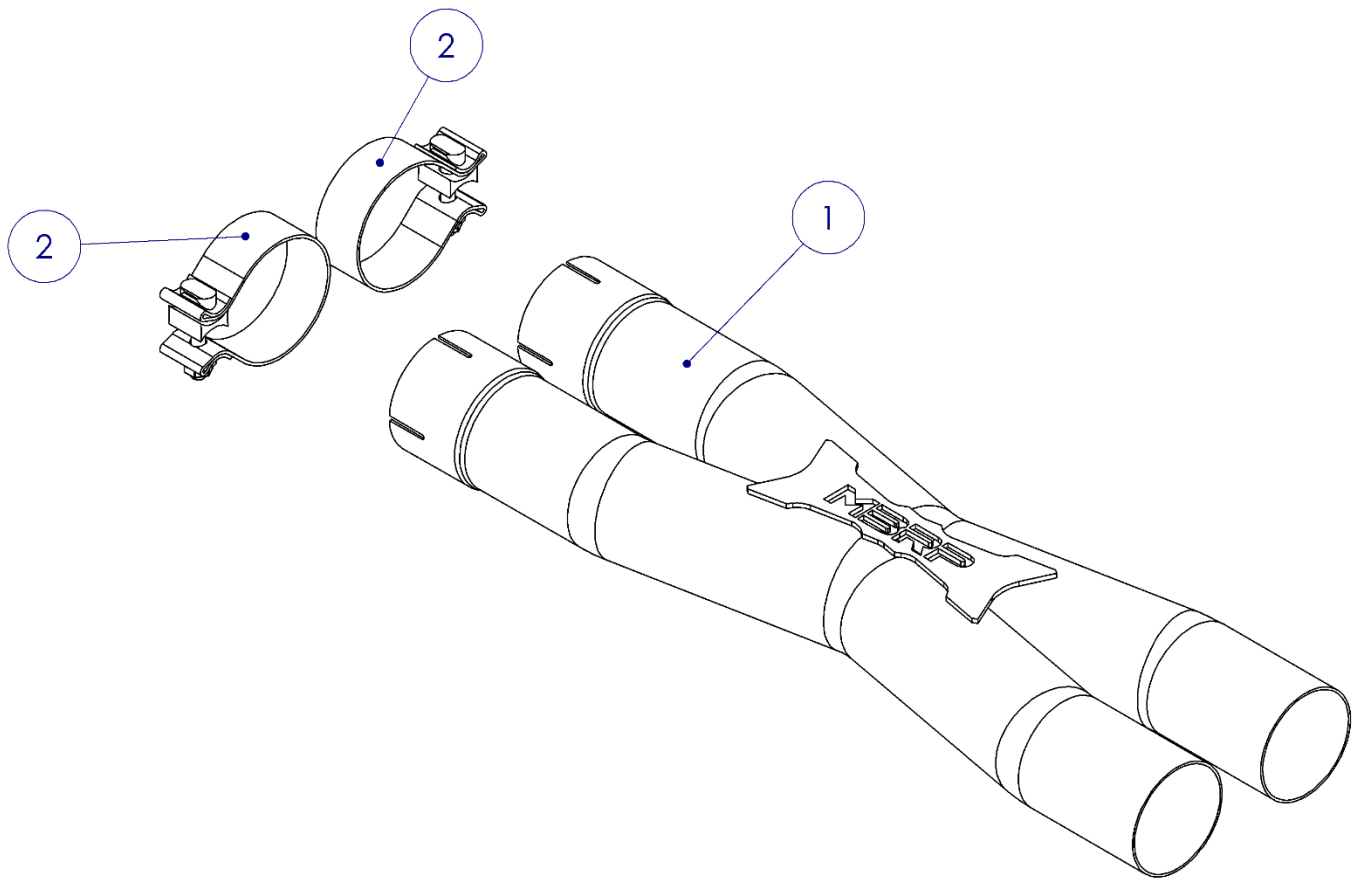

ITEM	DESCRIPTION	QTY
1	X PIPE ASSEMBLY	1
2	2.75"CLAMP	2

## PLEASE READ BEFORE STARTING INSTALLATION

While MBRP has made every effort to ensure that all components of this system are of superior quality and properly packaged, it is the installer's responsibility to ensure the following before removal of the factory exhaust:

- that ALL components shown above are present.
- that ALL mating components fit together.
- that there are no damaged components.
- that the system you have purchased is appropriate for your vehicle year, model and configuration.
- that the system will not interfere with any modifications previously installed or planned.
- that you have read and understand these instructions.

If you have any questions or are uncertain about any aspect of the installation of this system to your vehicle please contact your dealer before commencing installation.

# MBRP

## Removal of Stock System



**Figure 1**



**Figure 2**



**Figure 3**



**Figure 4**

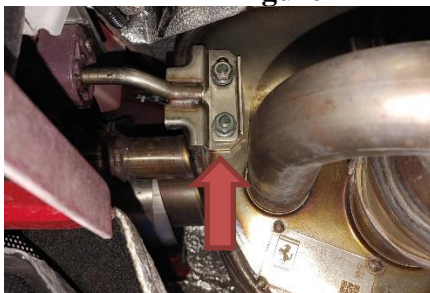

**Figure 5**

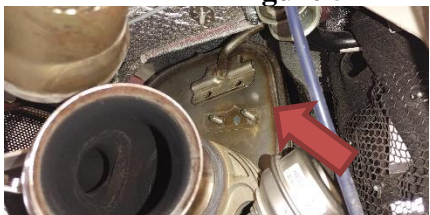
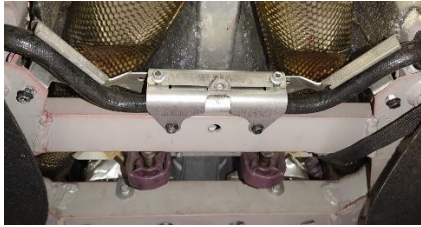

**Figure 6**

1. Apply penetrating lubricant liberally to all exhaust fasteners, hangers and rubber insulators.
2. Remove underpan between OEM H pipe and the rear axle.  
**Refer to Figure 1.**
3. Remove rear diffuser. Note: Be sure to disconnect electrical connector for the active air actuator before fully removing the diffuser.  
**Refer to Figure 2 and 3.**
4. Loosen the clamps that secure the mufflers to the extension pipes.
5. Remove the support brace that connects both mufflers together.  
**Refer to Figure 4.**
6. Loosen and remove both inner muffler hangers from the mufflers and lower the mufflers down and out of the way of the extension pipes.  
**Refer to Figures 5 and 6.**
7. Remove the heat shield protecting the hose located just ahead of the extension pipe hangers.  
**Refer to Figure 7.**
8. Unbolt the extension pipe hangers from the extension pipes.
9. Remove both heat shields from the front transaxle mounts.  
**Refer to Figure 8.**
10. Loosen the clamps securing the extension pipes to the OEM H pipe. Slide the extension pipes as far rearward as possible.  
**Refer to Figure 9.**
11. Loosen the clamps securing the OEM H pipe to the front pipes. Remove the OEM H pipe by sliding it rearward.

# MBRP

## Installation of MBRP Performance Exhaust



**Figure 7**



**Figure 8**



**Figure 9**



**Figure 10**

1. Install the 2.75" Clamps onto the inlets of the X pipe Assembly.

2. Install the X Pipe Assembly onto the outlets of the front pipes and tighten the clamps enough to just prevent movement. Refer to Figure 10.

3. Slide the extension pipes forward, onto the outlets of the X Pipe Assembly and secure with the OEM clamps.

4. Reinstall the OEM components in the reverse order as described above. Ensure the muffler outlets are centered in the bezels on the rear fascia before tightening all clamps.

5. Align the edge of each band clamp with the edge of the joint it is connecting. Tighten all hardware and clamps, starting at the front and working rearward to secure the system. Check along the full length of the exhaust system to ensure there is adequate clearance for fuel lines, vent lines, brake lines, frame, bodywork, suspension, and any wiring, etc. If there is any interference detected, relocate, or adjust to provide adequate clearance. Ensure all clamp connections are secure and components are unable to rotate or slide. Band clamps require approximately 45 lb-ft (60 N-m) of torque. Verify clearances, system security and band clamp torque after 30-60 miles (50-100 km) of driving.



**Congratulations!** You are ready to begin experiencing the improved power, sound and driving experience of your **MBRP** Performance Exhaust. We know you will enjoy your purchase!