

# Installation instructions

For set # 7.3120  
95-99 NISSAN SENTRA  
REAR SUSPENSION BEAM BUSHINGS

**ENERGY**  
**SUSPENSION** 

1131 VIA CALLEJON, SAN CLEMENTE, CA 92673

© 2007 Energy Suspension. All rights reserved.  
May not be reproduced, in any form, or by any means,  
without the written consent of Energy Suspension.

It is recommended that if you are unfamiliar with this type of work that you refer to a qualified service center specializing in this type of work. It is also recommended that if you choose to do this work yourself that a factory service manual be obtained for the proper procedures pertaining to removal, replacement and proper torque specifications for your vehicle. This instruction set is intended as a guideline for the safe installation of Energy Suspension's polyurethane bushings, once you have removed the factory components from your vehicle.

Do not remove outer metal shell of bushing, it must be reused for this bushing set to work.



To remove rubber bushing, apply low heat evenly around the outside of the outer metal shell, just enough to break the bond with the rubber. When you see light smoke coming from the sides of the bushing the bond should be broken. At no time should there be any flames coming from the rubber, if there are any flames, you need to back off with the heat. Just push the old rubber and inner metal sleeve out. Let the outer metal shell cool off before cleaning the inside.

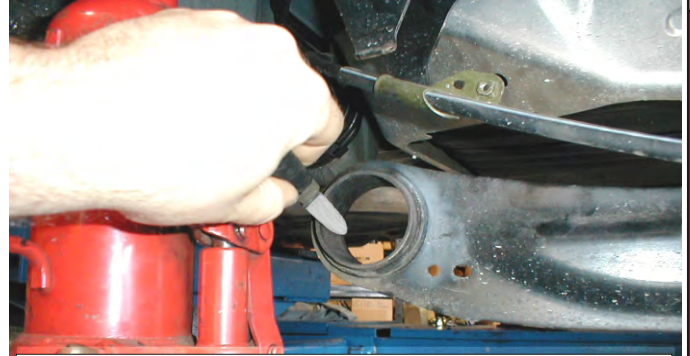

Let metal shell cool before cleaning inside. Remove any burrs and sharp edges before applying grease.

## Parts list for set 7.3120

- 2 - 3306 (polyurethane bushing).
- 2 - 15.10.472.39 (sleeve .875"O.D. x .500" I.D. x 2.355"LG).
- 4 - 9.11108 (grease).
- 1 - 17364 (this instruction sheet).



The cutouts on bushing 3306 must be facing up.

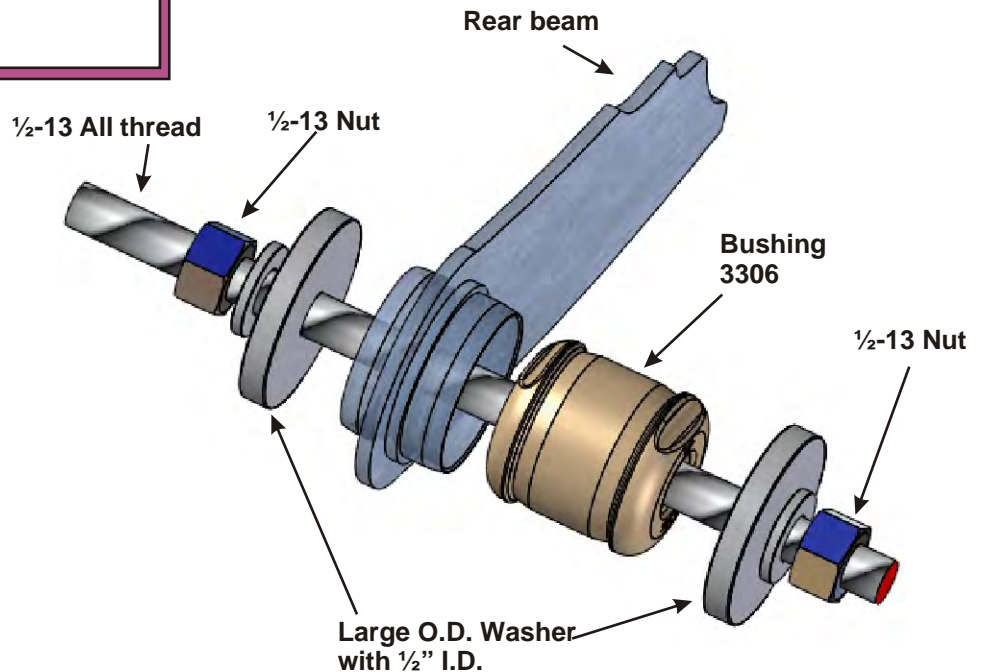

Suggested method for installing new polyurethane bushings and new inner metal sleeve. The following hardware is not included in this set and can be found at your local hardware store. This is only a suggestion to give you an idea on how to install our polyurethane bushings, feel free to use whatever method is convenient. Grease I.D. of shell and O.D. of new polyurethane bushing before pressing it in. Grease I.D. of bushing and O.D. of supplied sleeve before pressing together. Apply grease to all metal parts that contact the polyurethane bushings.

17364

2/FEB/07 BRH