

INSTRUCTION SHEET FOR SET #7.3108

Read this instruction sheet thoroughly before initiating any work!

It is recommended that if you are unfamiliar with this type of work that you refer to a qualified service center specializing in this type of work. It is also recommended that if you choose to do this work yourself that a factory service manual be obtained for the proper procedures pertaining to removal, replacement and proper torque specifications for your vehicle. This instruction set is intended as a guideline for the safe installation of Energy Suspension's Polyurethane.

Remove 14mm nut from endlink on both sides of the car and tilt sway bar out of way.

Remove 22mm ball joint nut and break loose ball joint.

Remove 17mm strut rod bolts from control arm.

Remove 17mm control arm bolt at frame, remove front control arm.

Using heat, remove rubber bushing only. **DO NOT REMOVE SHELL.**

Remove all burrs inside shell, apply grease to bushings, sleeves, and the shell ID's. Install the bushings first then the sleeves.

Bushing #3312 goes toward "rear" of the car.

Reinstallation:

Using a jack placed under the ball joint, raise the arm to align the two strut arm studs into the control arm.

Tighten all bolts to factory specifications.



ENERGY SUSPENSION®

1131 VIA CALLEJON, SAN CLEMENTE, CA 92673

© 2004 Energy Suspension. All rights reserved.
May not be reproduced, in any form, or by any means,
without the written consent of Energy Suspension.

PARTS LIST:

- 2 - 3312 Control arm bushings with thrust washer
- 2 - 3311 Control arm bushings without thrust washer
- 2 - 15.10.329.39 Sleeves (0.875"x0.563"x2.500")

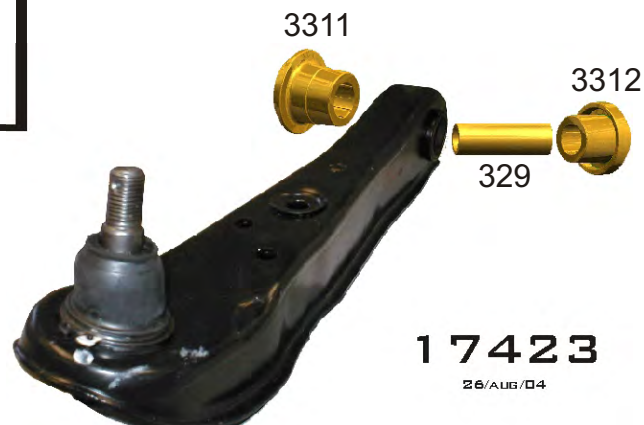

INSTRUCTION SHEET FOR SET #7.3108

Read this instruction sheet thoroughly before initiating any work!

It is recommended that if you are unfamiliar with this type of work that you refer to a qualified service center specializing in this type of work. It is also recommended that if you choose to do this work yourself that a factory service manual be obtained for the proper procedures pertaining to removal, replacement and proper torque specifications for your vehicle. This instruction set is intended as a guideline for the safe installation of Energy Suspension's Polyurethane.

Remove 14mm nut from endlink on both sides of the car and tilt sway bar out of way.

Remove 22mm ball joint nut and break loose ball joint.

Remove 17mm strut rod bolts from control arm.

Remove 17mm control arm bolt at frame, remove front control arm.

Using heat, remove rubber bushing only. **DO NOT REMOVE SHELL.**

Remove all burrs inside shell, apply grease to bushings, sleeves, and the shell ID's. Install the bushings first then the sleeves.

Bushing #3312 goes toward "rear" of the car.

Reinstallation:

Using a jack placed under the ball joint, raise the arm to align the two strut arm studs into the control arm.

Tighten all bolts to factory specifications.



ENERGY SUSPENSION®

1131 VIA CALLEJON, SAN CLEMENTE, CA 92673

© 2004 Energy Suspension. All rights reserved.
May not be reproduced, in any form, or by any means,
without the written consent of Energy Suspension.

PARTS LIST:

- 2 - 3312 Control arm bushings with thrust washer
- 2 - 3311 Control arm bushings without thrust washer
- 2 - 15.10.329.39 Sleeves (0.875"x0.563"x2.500")

