

Installation Instructions

5.3122

1997-2004 Dakota 2WD 1999-2003 Durango 2WD



1131 VIA CALLEJON, SAN CLEMENTE, CA 92673

© 2008 Energy Suspension. All rights reserved.
May not be reproduced, in any form, or by any means,
without the written consent of Energy Suspension.

This instruction sheet is intended as a guideline for the safe installation of Energy Suspension's polyurethane bushings, after you have removed the factory components from your vehicle. In most cases, various suspension components will need to be removed or relocated in order to install the new polyurethane bushings. Depending on the expertise of the installer, a factory service manual may need to be obtained in order to properly remove and install the various suspension components associated with the installation of the new polyurethane bushings. If the installer is unfamiliar with the removal and installation of the vehicle's suspension components, we recommend seeking the help of a qualified service center specializing in suspension systems.

Upper Control Arm

Removal:

Remove the arm from the suspension assembly. Apply light heat evenly around the outside of the outer metal casing, just enough to brake the bond with the rubber. When you see light smoke coming from the sides of the bushing the bond should be broken. At no time should there be any flames coming from the rubber, if there are any flames, you need to back off with the heat. Just push the old rubber and inner metal sleeve out. Let the outer metal casing cool off before cleaning the inside.

Installation:

With the rubber bushings removed and the inside of the shell cleaned, you are ready to install the new polyurethane bushings. Generously coat all metal surfaces that come into contact with polyurethane with the provided grease. Loosely assemble the bushings and sleeves into the shells far enough to start the nut on the cross shaft. Tighten the nuts on both sides until the bushings are completely seated in the shell (Figure 1). Tighten to factory torque settings. Install arm into suspension assembly.

Lower Control Arm

Removal:

Remove the Lower Arm from the suspension assembly. Apply light heat evenly around the outside of the outer metal casing, just enough to brake the bond with the rubber. When you see light smoke coming from the sides of the bushing the bond should be broken. At no time should there be any flames coming from the rubber, if there are any flames, you need to back off with the heat. Just push the old rubber and inner metal sleeve out. Let the outer metal casing cool off before cleaning the inside.

Installation:

With the rubber bushings removed and the inside of the shell cleaned, you are ready to install the new polyurethane bushings. Generously coat all metal surfaces that come into contact with polyurethane with the provided grease. Simply slide in the new polyurethane bushings and sleeve into the shell. Use a vise or similar tool to completely seat the new bushings and sleeves into the shells. Once this is completed, you can install the lower arm into the suspension assembly. Torque bolts to factory settings.

BILL OF MATERIALS

2 - 3500 Lower Control Arm Front Position
2 - 3501 Lower Control Arm Rear Position
4 - 3034 Upper Control Arm
2 - 15.10.08.39 (.750" OD x .563" ID x 3.00" L)
2 - 15.10.170.39 (.750" OD x .480" ID x 2.40" L)
4 - 15.10.373.39 (1.00" OD x .687" ID x 1.96" L)
4 - 9.11101 Grease
17544 - Instructions

3034 w/ 15.10.373.39 Sleeve

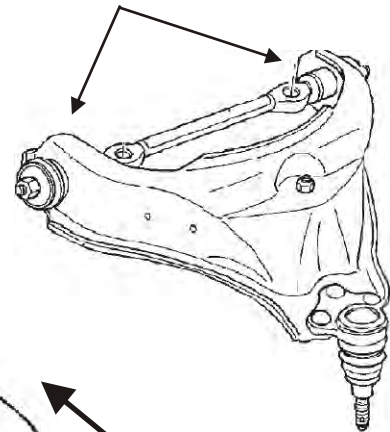

Front of Vehicle

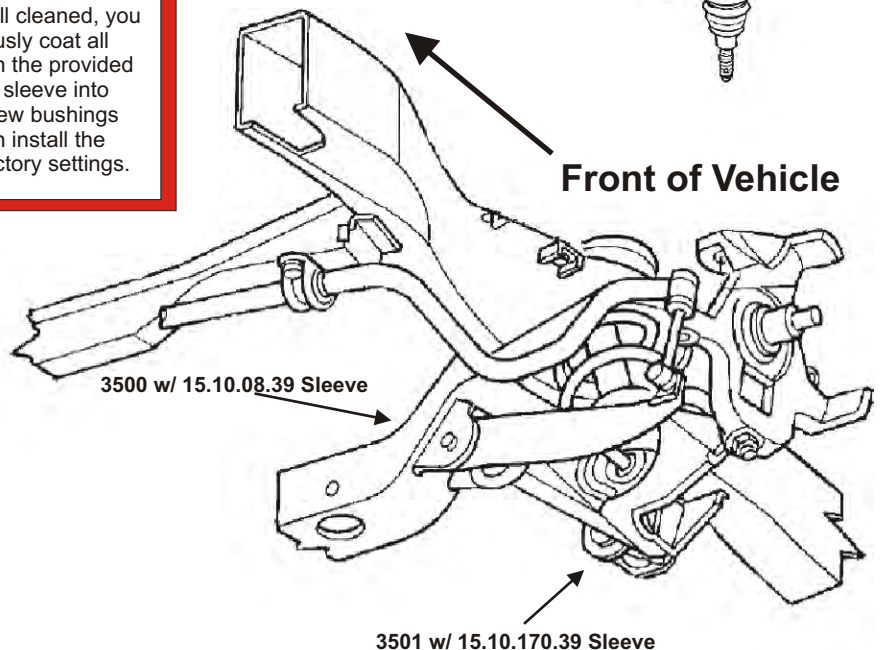

Figure 1



17544

8/June/09 NK