

# Installation Instructions Set# 5-3116

\*\*\*Carefully read the instructions before starting installation

1. Properly support the vehicle on the frame.
2. Remove the lower control arm.
3. Remove the sleeve and rubber bushing (horizontal bushing) from the front position of the control arm. DO NOT remove or damage the bushing shells from the control arm. Remove the rubber bushing.
4. Remove the rubber bushing and shell (vertical bushing) from the rear pivot position. At this point you must file the face of the control arm down flat. On the horizontal bushing measure and scribe a mark that is 1.390(1-25/64)-1.422(1-27/64) inches back from the face of the shell (see diagram) Press the shell partially out and grind the area flat and smooth up to the scribe line. Do not grind too much off.
5. Double check all the faces of the control arm and make sure they are all smooth and flat (both the vertical and horizontal bushing location). See diagram for details. Press the horizontal bushing shell all the way into the control arm.
6. Grease the I.D. and the face of the control arm and shell. Grease both the vertical and horizontal position thoroughly.
7. Grease all surfaces of the bushing that come into contact with metal thoroughly. Grease the sleeves. Install the bushings and sleeves.
8. Reinstall the control arm. It may be necessary to enlarge the gap at the rear mount for the vertical bushing to fit. To ease installation, install the rear vertical mount first. Then push the strut and spindle out of the way and install the front (horizontal) bushing.
9. Tighten all fasteners.

**IMPORTANT: Coat polyurethane bushing, sleeve and arm I.D. with supplied grease.**

Updated 15/FEB/02 BRH  
3/19/97 KN  
17135

## "Vertical" Bushing

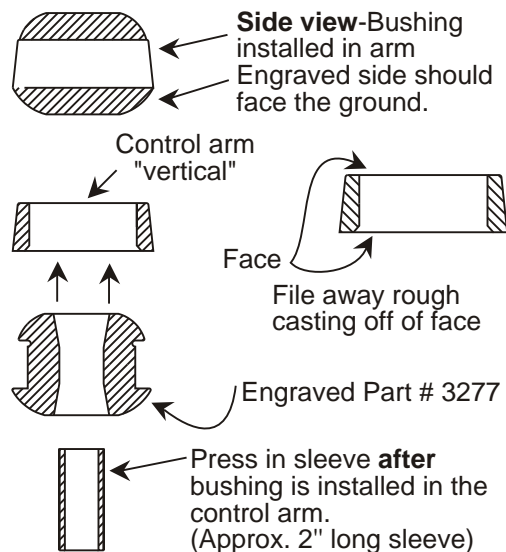

© 2002 Energy Suspension. All rights reserved.  
May not be reproduced, in any form, or by any means, without the written consent of Energy Suspension.

## Lower Control Arm

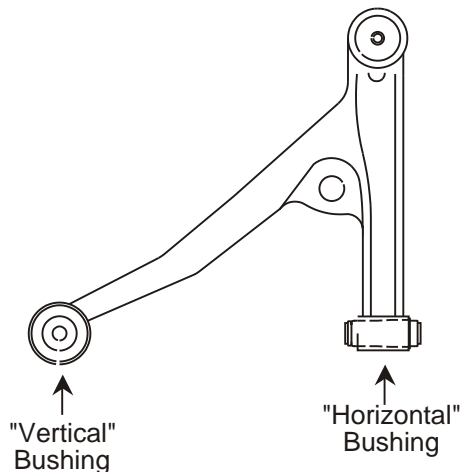

## "Horizontal" Bushing

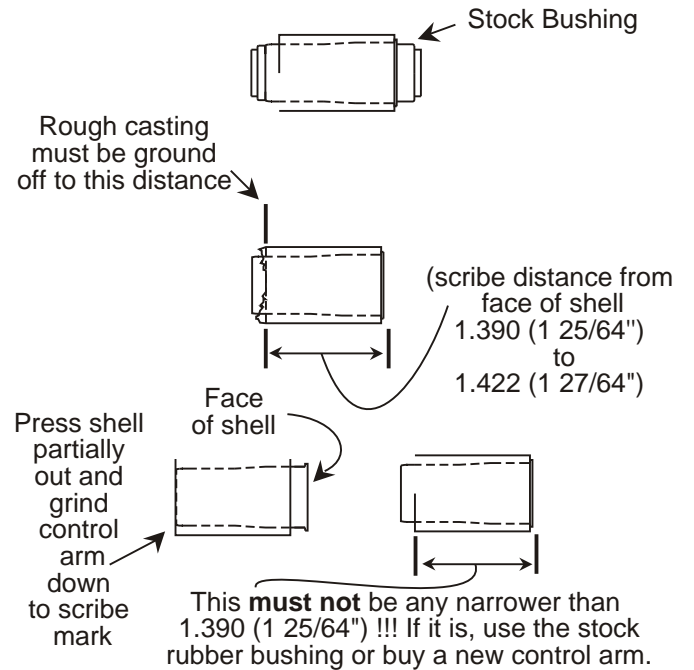

**It is recommended that a factory service manual be purchased prior to performing any work on your car or truck.**

## Control Arm "Horizontal"

