

# Ford C-bushing installation instructions

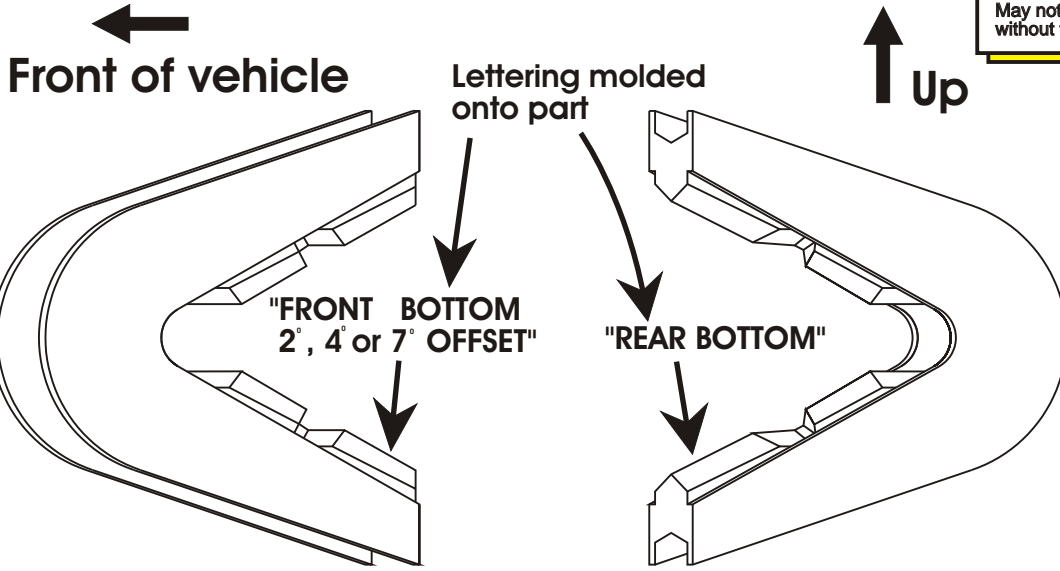

1131 VIA CALLEJON, SAN CLEMENTE, CA 92673

© 2002 Energy Suspension. All rights reserved.  
May not be reproduced, in any form, or by any means,  
without the written consent of Energy Suspension.



C-bushings are available in 2,4 and 7 degree positive caster. The recommended usage for the C-bushings is:  
  
2degree Offset for stock to 2" lift,  
4 degree Offset for 2" to 4" lift and the  
7 degree Offset for more than a 4" lift.

Assemble the C-bushing orienting the lettering molded on the part as shown above.

17231  
122302NJT

# Ford C-bushing installation instructions



1131 VIA CALLEJON, SAN CLEMENTE, CA 92673

© 2002 Energy Suspension. All rights reserved.  
May not be reproduced, in any form, or by any means,  
without the written consent of Energy Suspension.

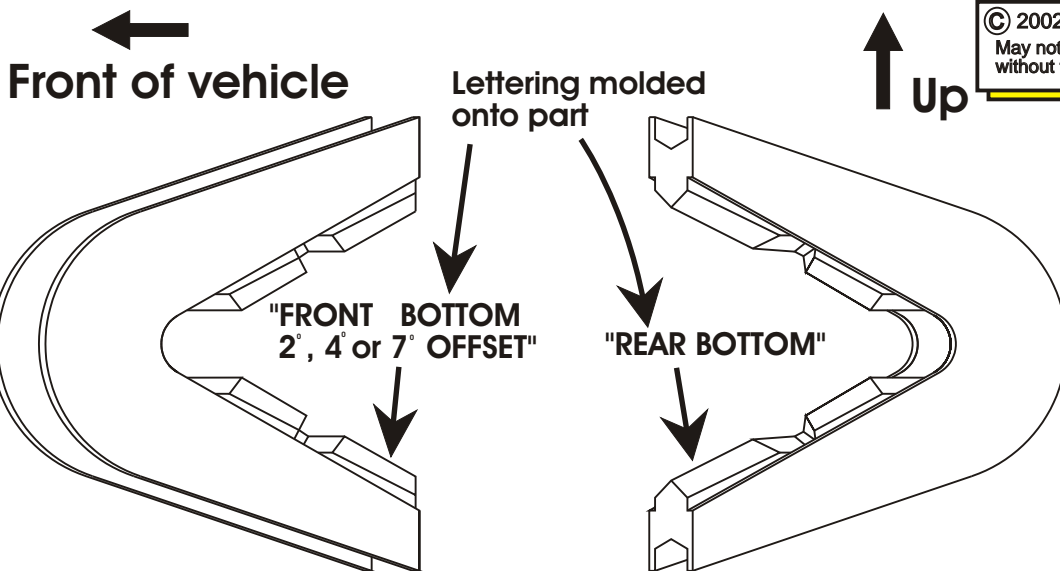

C-bushings are available in 2,4 and 7 degree positive caster. The recommended usage for the C-bushings is:  
  
2degree Offset for stock to 2" lift,  
4 degree Offset for 2" to 4" lift and the  
7 degree Offset for more than a 4" lift.

Assemble the C-bushing orienting the lettering molded on the part as shown above.

17231  
122302NJT