

Installation Instructions

For Set # 3.4173

68-70 Chevrolet Biscayne, Bel Air,
Caprice & Impala Body Mounts
Includes Standard Wagon & Convertible



1131 VIA CALLEJON, SAN CLEMENTE, CA 92673

© 2022 Energy Suspension. All rights reserved.
May not be reproduced, in any form, or by any means,
without the written consent of Energy Suspension.

It is recommended that you refer to a qualified service center if you are unfamiliar with vehicle chassis and suspension repair work. This instruction is intended as a guideline for the safe installation of Energy Suspension polyurethane bushings after original equipment has been removed from the vehicle. Reference the vehicle manufacturer's service manual for component removal and replacement procedures and torque specifications. Before beginning work, read installation instructions and verify parts received match P/N's and quantities in the parts list. In the case of a discrepancy, contact Energy Suspension Customer Service (949-361-3935). Energy Suspension parts are designed to work with vehicles in a good state of repair. We cannot be held responsible for suspension or steering related problems occurring due to poor vehicle maintenance. Wheel alignment is altered when suspension components are removed and replaced. It is highly recommended that your vehicle is checked and adjusted by a qualified alignment shop prior to use.

PARTS LIST:

2 EA 4192	POS. 4 UPPER	8 EA 15.03.28.39	2-1/2" X 3/4" X 1/8" FLAT WASHER
2 EA 4193	POS. 4 LOWER	2 EA 15.03.34.39	2-1/2" X 7/16" X 1/8" FLAT WASHER CLIPPED
2 EA 04P04377	68 CORE SUPPORT UPPER	2 EA 15.03.85.39	1-3/8" X 15/32" X 3/16" FLAT WASHER
2 EA 04P04378	68 CORE SUPPORT LOWER	12 EA 15P0314942	1" X .15/32" X 1/8" FLAT WASHER
6 EA 04P04380	POS. 5, 6 & 7 LOWER	8 EA 15.05.08.39	7/16-14 X 3" BOLT
2 EA 04P04390	69-70 CORE SUPPORT LOWER	6 EA 15.05.76.39	7/16-14 X 2-1/2" BOLT
2 EA 04P04391	69-70 CORE SUPPORT UPPER	2 EA 15.07.02.40	7/16-14 LOCK NUT
8 EA 04P04392	POS. 1, 5, 6 & 7 UPPER	2 EA 15P0704342	7/16-14 FLANGED HEX NUT
2 EA 04P04393	POS. 1 LOWER	2 EA 15.10.03.39	3/4" X 1/2" X 1-13/32" SLEEVE
6 EA 04P04394	POS. 2, 3 & 5 UPPER	2 EA 15.10.16.39	7/8" X 3/4" X 1-15/16" SLEEVE
4 EA 15.03.07.39	2-1/2" X 7/16" X 1/8" FLAT WASHER	2 EA 15.10.40.39	7/8" X 5/8" X 1-1/2" SLEEVE
10 EA 15.03.09.39	2" X 7/16" X 1/8" FLAT WASHER	6 EA 15.10.59.39	7/8" X 3/4" X 1-1/2" SLEEVE
4 EA 15.03.13.39	1-3/4" X 7/16" X 1/8" FLAT WASHER	2 EA 15.10.115.39	3/4" X 5/8 X 1" SLEEVE

Read this instruction sheet thoroughly before initiating any work!

NOTE: Variances may exist between your vehicle's construction and the mount position diagrams shown in these instructions. In the 1960's vehicle assembly lines would sometimes use up inventory from the previous model year or use a substitute part from another vehicle line if inventory ran out. There were also mid-year design changes. For these reasons, it is impractical for us to show every combination of body mount installed at the time of manufacture. This body mount set has enough bushings to cover almost every vehicle configuration. If you find that the mounts fit better when used in a different order than as depicted, then use your discretion to best accommodate your vehicle's unique fitment requirements. Furthermore, you may prefer to fit a mount in every frame position even if your vehicle didn't come that way originally.

REMOVAL ORDER: Remove the front bumper, bumper bracket to frame and bumper brace. 1968, 1969 and 1970 bumpers were different for each year. Take pictures and record the disassembly. Remove both inner fender braces from the fender panel to frame to gain access to the square nut in the firewall for position 1 body mounts (PIC. 1). Remove the fan shroud and let it rest on the engine (PIC. 2) Remove steering coupler rag joint (PICS. 3 & 4). Remove parking brake cable stud adjusting nut from equalizer and remove retaining clip at inner frame between positions 1 & 2 driver side (PIC. 5). Remove ground strap from body to inner frame near position 2 passenger side (PIC. 6). Replace all removed parts at completion of the job.

CAUTION: Only remove body mount bolts from one side of vehicle. (Except sedan position # 5 body mount bolt must be removed from both sides). Just loosen body mount bolts on opposite side of vehicle. Raise side of vehicle body with bolts removed just high enough to remove/replace mounts. When removing O.E. body mounts, be sure to note number and position of any shims that may have been used to align body. These shims must be reused in their original positions to retain proper body alignment. Always keep doors shut and maintain a watchful eye on the fan shroud, brake lines, shift linkage, fuel lines and various hoses for sufficient clearance when raising body. Never place jack cradle directly against body panels; instead use 2x4 wooden blocks or equivalent to spread jack force. Good places for body jack points are just behind front fender well and just in front of rear fender well. On wagons, a 3rd jack may also be needed behind rear fender well. Always jack body evenly, avoiding one jack lifting more than others. When upper mounts are installed and body is resting on them, check to see if any upper mounts are loose. If so, additional shims may be needed (not included in this set) to take up the gap. Torque all bolts to factory specifications. 30-45 FT-LBS or until the bolt bottoms out on the inner sleeve.

RUST: Older vehicles are going to have rust. The amount of rust will depend on the location and condition of the vehicle being worked on. This kit includes hardware like nuts, bolts and washers but it does not include the captured nuts inside the body that are inaccessible from the outside. If any of the bolts snap off or strip out the threads during removal you may have to cut open the body panel to remove and replace the captured nut. Also the frame and frame perches have been known to rust out to the same diameter as the old rubber body mount or the metal ring inside the original rubber body mount will rust and stick to the frame perch making the hole seem smaller. In these cases the frame perch will need to be replaced or the rusty metal ring will need to be knocked out.

Installation Instructions

For Set # 3.4173

68-70 Chevrolet Biscayne, Bel Air,
Caprice & Impala Body Mounts
Includes Standard Wagon & Convertible

ENERGY
SUSPENSION

1131 VIA CALLEJON, SAN CLEMENTE, CA 92673

© 2022 Energy Suspension. All rights reserved.
May not be reproduced, in any form, or by any means,
without the written consent of Energy Suspension.



1
Removal of fender well brace is necessary for proper clearance when lifting body.



2
Remove the fan shroud and let it rest on the engine.

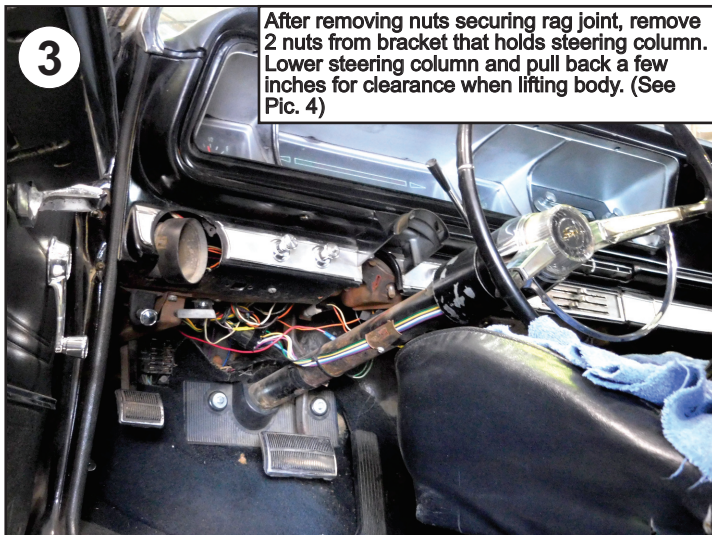

3
After removing nuts securing rag joint, remove 2 nuts from bracket that holds steering column. Lower steering column and pull back a few inches for clearance when lifting body. (See Pic. 4)



4
With fender well removed you have better access to rag joint at steering box.

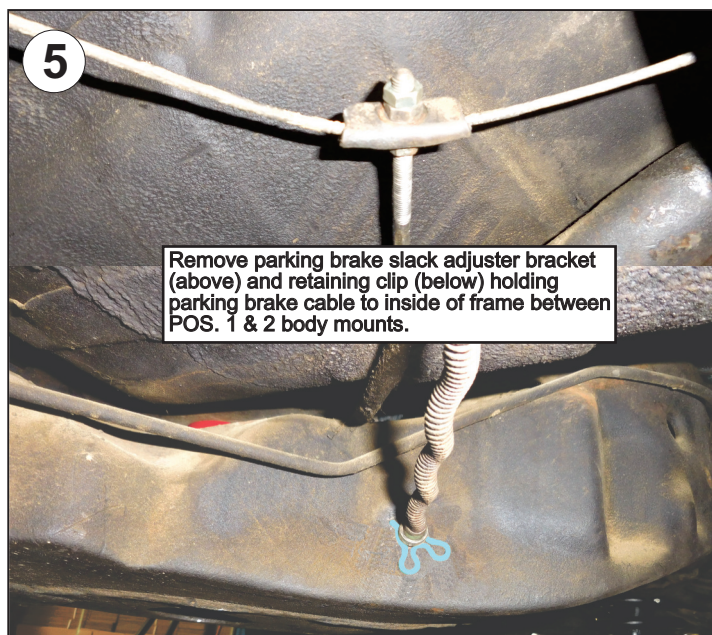

5
Remove parking brake slack adjuster bracket (above) and retaining clip (below) holding parking brake cable to inside of frame between POS. 1 & 2 body mounts.

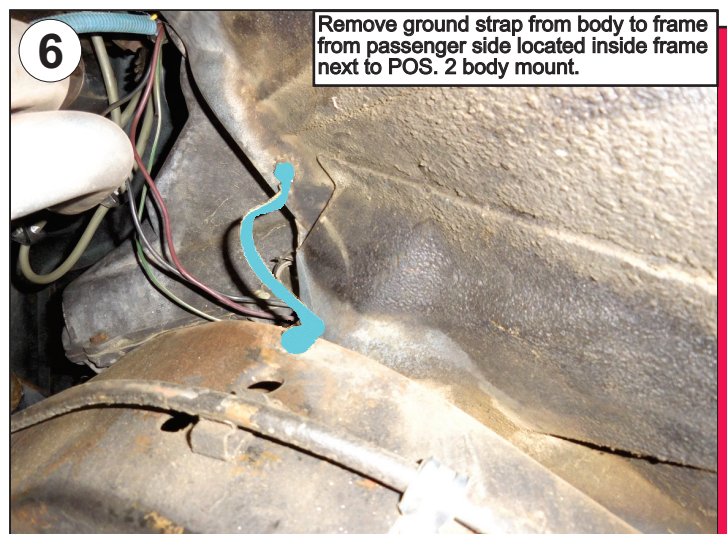

6
Remove ground strap from body to frame from passenger side located inside frame next to POS. 2 body mount.

Installation Instructions

For Set # 3.4173

68-70 Chevrolet Biscayne, Bel Air,
Caprice & Impala Body Mounts
Includes Standard Wagon & Convertible

ENERGY
SUSPENSION

1131 VIA CALLEJON, SAN CLEMENTE, CA 92673

© 2022 Energy Suspension. All rights reserved.
May not be reproduced, in any form, or by any means,
without the written consent of Energy Suspension.

Mount Position Diagram

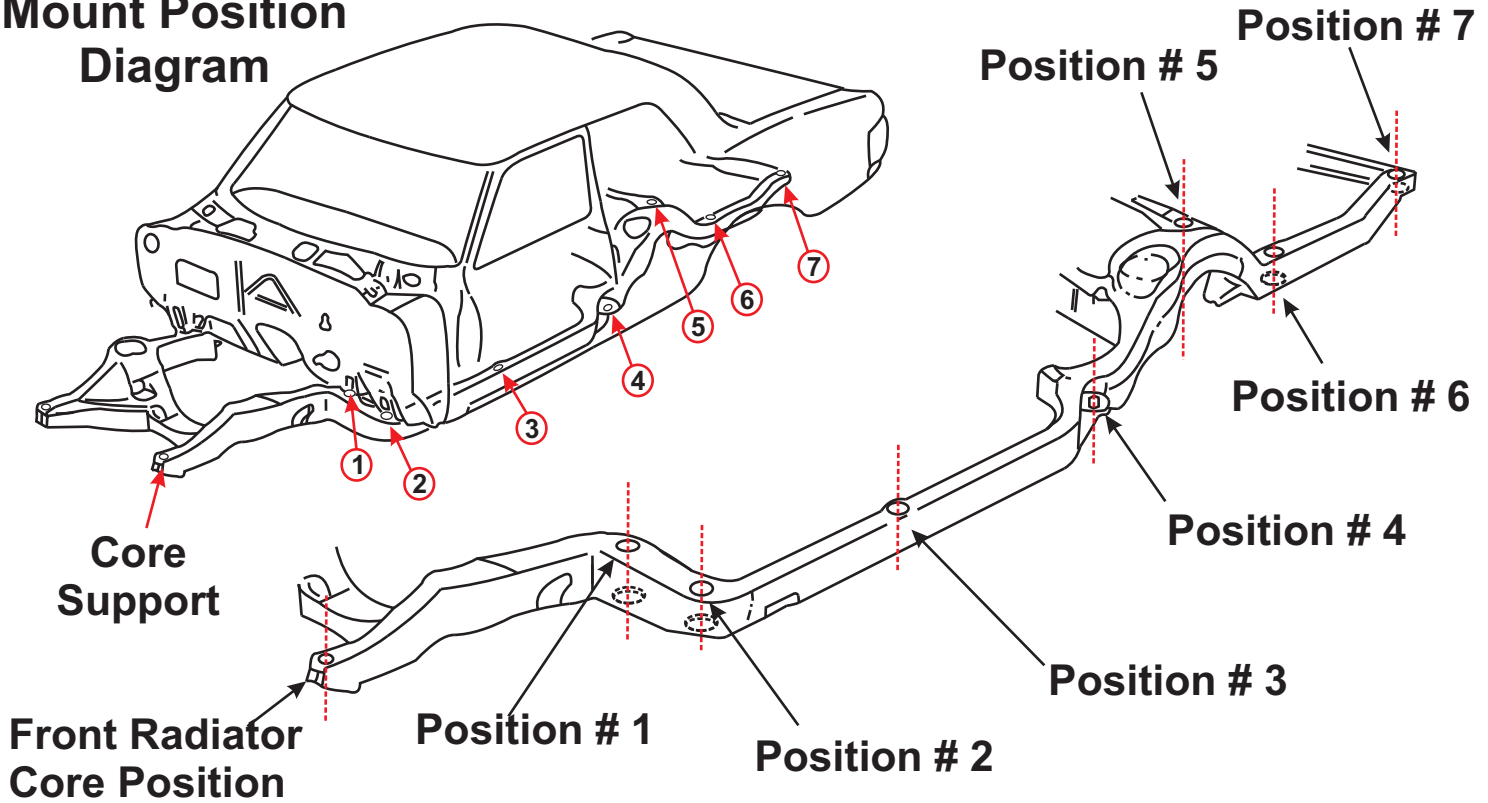

CORE SUPPORT 1968

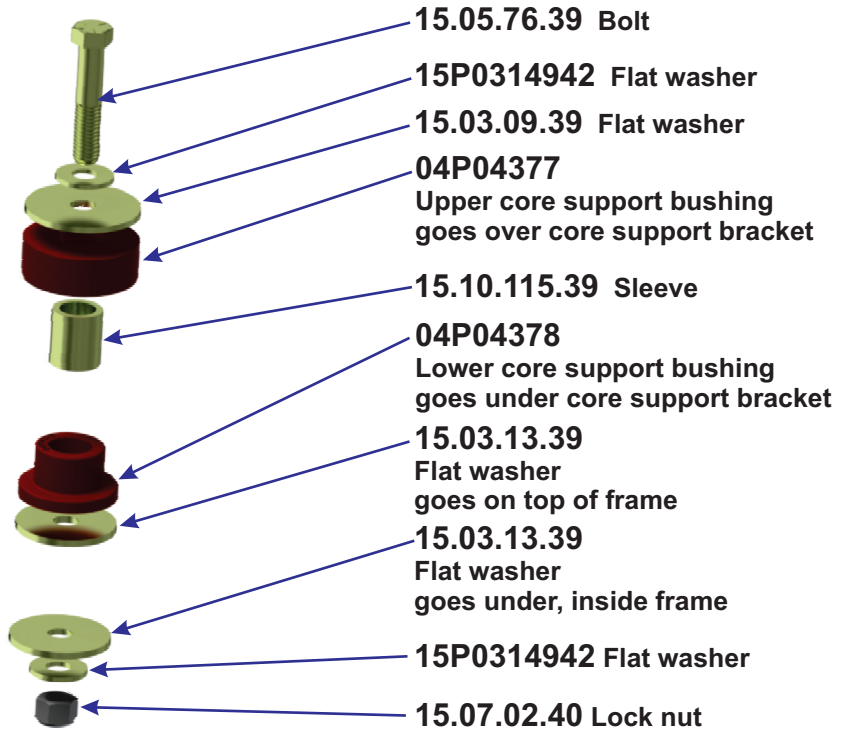
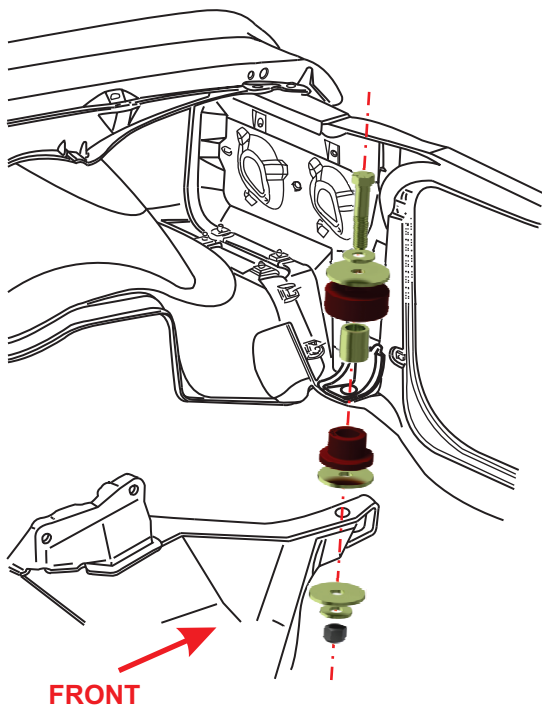

Installation Instructions

For Set # 3.4173

68-70 Chevrolet Biscayne, Bel Air,
Caprice & Impala Body Mounts
Includes Standard Wagon & Convertible



1131 VIA CALLEJON, SAN CLEMENTE, CA 92673

© 2022 Energy Suspension. All rights reserved.
May not be reproduced, in any form, or by any means,
without the written consent of Energy Suspension.

CORE SUPPORT 1969-70

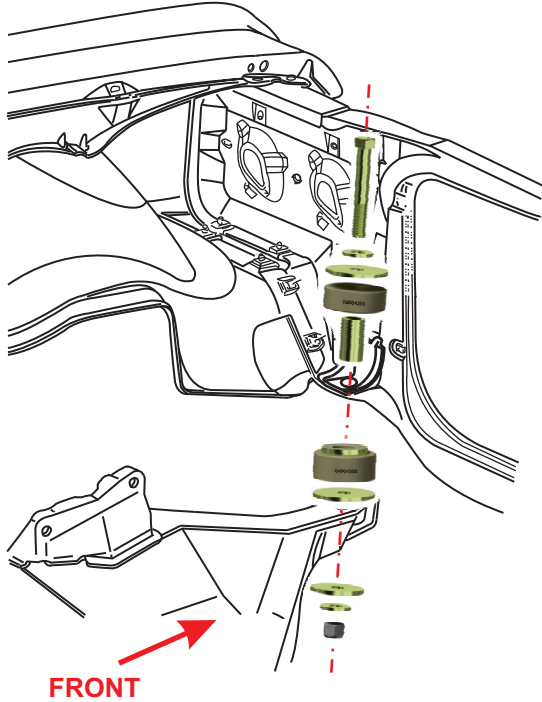

- 15.05.08.39 Bolt
- 15P0314942 Flat washer
- 15.03.09.39 Flat washer
- 04P04391
Upper core support bushing
goes over core support bracket
- 15.10.03.39 Sleeve
- 04P04390
Lower core support bushing
goes under core support bracket
- 15.03.09.39 Flat washer
goes on top of frame
- 15.03.13.39 Flat washer
goes under, inside frame
- 15P0314942 Flat washer
- 15.07.02.40 Lock nut

POSITIONS 1, 2 & 3

15P0704342
7/16-14 Flanged hex nut
Replacement for O.E. caged
nut if needed

15.03.85.39 Washer
Goes under flanged hex
nut inside body

15.03.34.39 Clipped Washer

04P04392 Bushing

15.10.40.39 Sleeve

04P04393 Bushing

15P0513939 Bolt

****Position #1 NOTE****
The clipped area on
washer must be placed
toward firewall to clear
the angled area.

15.03.07.39 Washer

15P0314942 Washer

Position # 3
Upper Only
Convertible
04P04394 Bushing

Position # 2
Upper Only
04P04394 Bushing

Core Position

Position # 1

17P17700 Page 4 of 5

Installation Instructions

For Set # 3.4173

68-70 Chevrolet Biscayne, Bel Air,
Caprice & Impala Body Mounts
Includes Standard Wagon & Convertible

ENERGY
SUSPENSION

1131 VIA CALLEJON, SAN CLEMENTE, CA 92673

© 2022 Energy Suspension. All rights reserved.
May not be reproduced, in any form, or by any means,
without the written consent of Energy Suspension.

POSITIONS 4, 5, 6 & 7

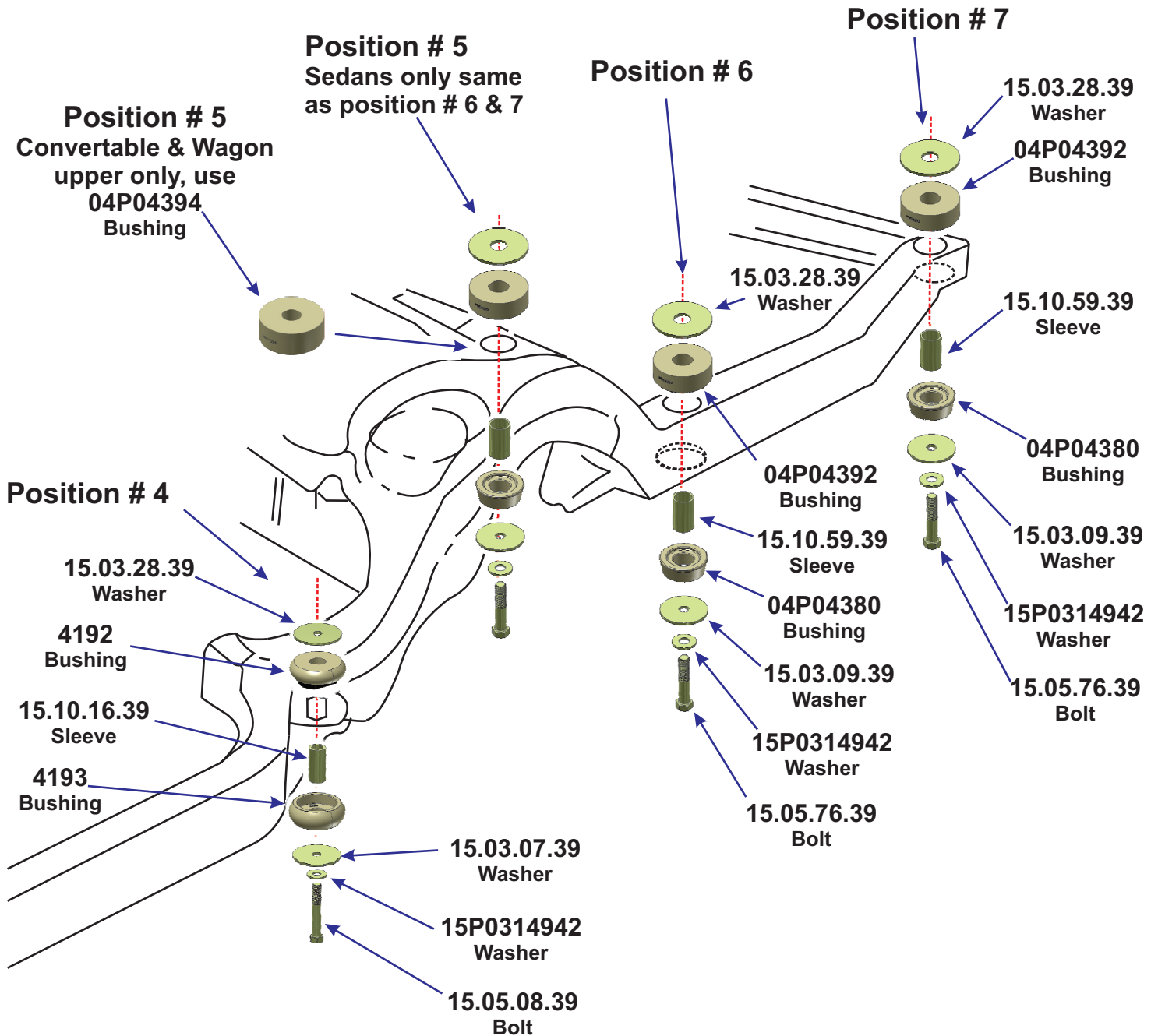

NOTE: ONE SIDE AT A TIME!!!

Install mounts one side at a time
with bolts on other side loosened
only (Sedans only must have
position # 5 body mount bolt
removed from both sides).