

Installation Instructions

3.4167

1960-64 Chevrolet Impala Convertible Body Mounts



1131 VIA CALLEJON, SAN CLEMENTE, CA 92673

© 2008 Energy Suspension. All rights reserved.
May not be reproduced, in any form, or by any means, without the written consent of Energy Suspension.

It is recommended that if you are unfamiliar with this type of work that you refer to a qualified service center specializing in this type of work. It is also recommended that if you choose to do this work yourself that a factory service manual be obtained for the proper procedures pertaining to removal, replacement and proper torque specifications for your vehicle. This instruction set is intended as a guideline for the safe installation of Energy Suspension's polyurethane bushings, once you have removed the factory components from your vehicle.

Front Clip: BILL OF MATERIALS

- 2 - 15.03.69.39 (.812"x.406"x.100") Washer
- 2 - 15.05.36.39 (3/8"-16x1.00") Bolt
- 2 - 15.06.14.39 Welded Plate w/ Nut

Position 1-6:

- 12 - 4264 Upper
- 12 - 4265 Lower
- 12 - 15.03.07.39 (2.500"x.437"x.120") Upper Washer
- 12 - 15.03.09.39 (2.0"x.437"x.120") Lower Washer
- 12 - 15.05.08.39 (7/16"-16x3") Bolt
- 12 - 15.10.321.39 (.750"x.500"x1.500") Sleeve

Important Information

Always use some kind of material to disperse the weight when lifting the body using a jack. Never place jack faces directly on body panels. If possible, use multiple jacks to ensure even lifting of the body.

Always watch the fan shroud, brake lines, and various hoses when lifting the body.

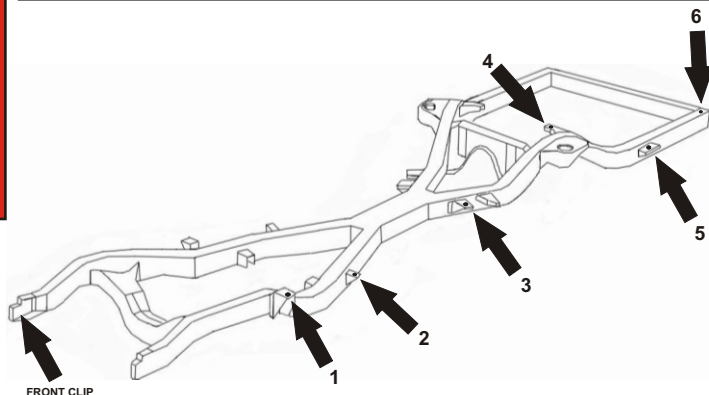

DIAGRAM 1

Removal and Installation

Loosen Positions 1, 5 and 6 on the driver and passenger sides but do not completely remove the bolts.

Completely remove bolts for positions 2, 3, and 4 on the driver and passenger sides. These inner positions, if not removed, could possibly damage the body when lifting it from the frame.

Removal:

Remove bolts from positions 1, 5, 6 and the Front Clip on one side of the vehicle. Use a jack and something to disperse the force of the jack on the body, typically a block of wood, to raise the body off the frame just enough to remove the old bushings and hardware. **Be cognizant of brake lines, the fan shroud, and various hoses when lifting the body.* Also, note the location and position of any existing shims that may be present, as you will need to return them to these positions when reinstalling to ensure proper body alignment.

Installation:

With the old bushings and hardware removed, install the upper poly bushings, washers and any pre-existing shims in positions 1, 2, 3, 4, 5, and 6. **See diagram 2 below for assembly order.* Lower the body until it is barely making contact with the mounts. With the body in this position, make sure the washers and poly bushings are properly aligned, add the lower bushing and washer, and start the bolts for all positions.

With the bolts started and the bushings and washers in place, set the body back onto the frame. Now, remove the bolts from positions 2, 3 and 4, so you can safely lift the body when installing on the opposite side. At the end of this step you should have poly bushings, washers and bolts loosely assembled in positions 1, 5 and 6 and upper bushings and washers aligned in positions 2, 3 and 4 on one side of the vehicle.

Follow the same steps for removal and installation on the opposite side.

Once positions 1, 5 and 6 on the passenger and driver sides have been loosely assembled and the body is fully resting on the mounts, you can install the bolts for positions 2, 3 and 4 on both sides. Torque all positions to 40 - 50lbs.

After the body mounts in positions 1, 2, 3, 4, 5, and 6 on the driver and passenger sides have been tightened to the proper torque specifications, use the provided hardware and Diagram 1 to secure the Front Clip positions.

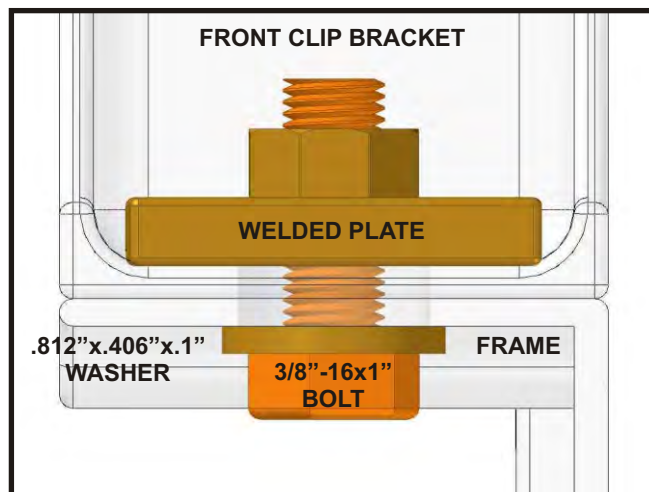

DIAGRAM 2

