

# Installation Instructions

## For Set # 3.4163

### 69-72 GMC C-10 PICKUP

### Body Mount Set

**ENERGY**  
**SUSPENSION**  **®**

1131 VIA CALLEJON, SAN CLEMENTE, CA 92673

© 2022 Energy Suspension. All rights reserved.  
May not be reproduced, in any form, or by any means,  
without the written consent of Energy Suspension.

It is recommended that you use a qualified service center if you are unfamiliar with vehicle chassis and suspension repair work. This instruction is intended as a guideline for the safe installation of Energy Suspension polyurethane bushings after the original equipment parts have been removed from the vehicle. Reference the vehicle manufacturer's service manual for component removal and replacement procedures and torque specifications. Before beginning work, read installation instructions and verify parts received match P/N's and quantities in the parts list. In the case of a discrepancy, contact Energy Suspension Customer Service (949-361-3935). Energy Suspension parts are designed to work with vehicles in a good state of repair. We cannot be held responsible for suspension or steering related problems occurring due to poor vehicle maintenance. Wheel alignment is altered when suspension components are removed and replaced. It is highly recommended that your vehicle is checked and adjusted by a qualified alignment shop prior to use.

**NOTE:** When disassembling the body mounts, be sure to note the number and position of shims that may have been used to align the body. These shims will have to be reused to retain proper body alignment.

**RUST:** OLDER vehicles have rust. The amount of rust will depend on the age, location and condition of the vehicle being worked on. This kit includes hardware like nuts, bolts and washers but it does not include the captured nuts inside the body that are inaccessible from the outside. If any of the bolts snap off or strip out the threads during removal you may have to cut open the body panel to remove and replace the captured nut. Also, the frame and frame perches may rust out to the same diameter as the old rubber body mount or the metal ring inside the original rubber body mount will rust and stick to the frame perch making the hole seem smaller. In these cases the frame perch will need to be replaced or the rusty metal ring will need to be knocked out.

**CAUTION:** Remove all the body mount bolts on one side of the vehicle. Loosen but do not remove all the body mount bolts on the opposite side of the vehicle. Remove the front bumper. Remove grounding strap at position 1 passenger side. Only raise one side of the vehicle at a time, lifting the body only high enough to remove/replace the mounts. Always watch the fan shroud, remove the fan or fan shroud if additional clearance is needed. Observe brake lines, shift linkage, steering shaft to steering gear box and various hoses for sufficient clearance when raising the body. Check the motor mounts; bad motor mounts may cause the fan to hit the fan shroud. When jacking the body, use a 2x4 or equivalent to spread the weight. Never place jack faces directly on body panels! When all mounts and hardware are installed, torque all bolts to factory specifications. Replace all items removed and re-heck all nuts and bolts before driving. Visually inspect and re-torque all fasteners after 200, 500 & 1000 miles. Recheck fasteners during routine vehicle service.

#### Parts list: 3.4163

- 2 - 04P04438 (Upper mount core support).
- 2 - 04P04439 (Lower mount core support).
- 2 - 04P04399 (Upper mount POS. 1).
- 2 - 04P04405 (Lower mount POS. 1).
- 2 - 04P04436 (Upper mount POS. 2).
- 2 - 04P04437 (Lower mount POS. 2).
- 6 - 15.03.07.39 (2-1/2" x 7/16" x .1/8" Flat washer POS. Core & POS. 2 Bottom).
- 2 - 15.03.13.39 (1-3/4" x 7/16" x 1/8" Flat washer POS. Core).
- 2 - 15.03.16.39 (2-1/2" x 9/16" x .1/8" Flat washer POS. 1 Lower).
- 4 - 15.03.84.39 (1-3/16" x .594" x .094" Flat washer POS. 1 Top & Bottom).
- 6 - 15.03.85.39 (1-3/8" x .470" x .172" Flat washer POS. Core & POS. 2 Bottom).
- 4 - 15.03.138.39 (3-1/2" x 9/16" x 1/8" Flat washer POS. 1 & 2 Upper).
- 2 - 15P0513940 (7/16-14 x 3-1/2" Bolt POS. Core).
- 2 - 15P0514140 (9/16-12 x 6" Bolt POS. 1).
- 2 - 15P0514240 (7/16-14 x 7" Bolt POS. 2)
- 2 - 15.07.02.40 (7/16-14 Nylock nut POS. Core).
- 2 - 15.07.05.40 (9/16-12 Nylock nut POS. 1).
- 2 - 15.10.15.39 (.875" x .687" x 2.300" Sleeve POS. 1).
- 2 - 15.10.392.39 (.875" x .563" x 1.600" Sleeve POS. Core).
- 2 - 15.10.414.39 (1.00" x .688" x 3.860" Sleeve POS. 2).
- 1 - 17P17732 (this instruction sheet).

## Mount Position Diagram

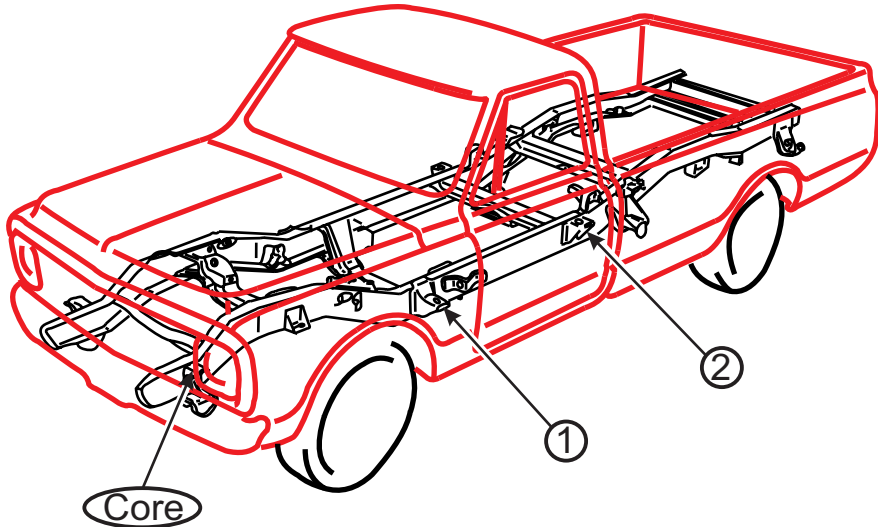

TORQUE BOLTS TO 35 - 55 LBS FT. OR UNTIL THE WASHERS BOTTOM OUT ON INNER SLEEVES.

## CORE POS.

With  $\varnothing 1-11/16"$  in frame

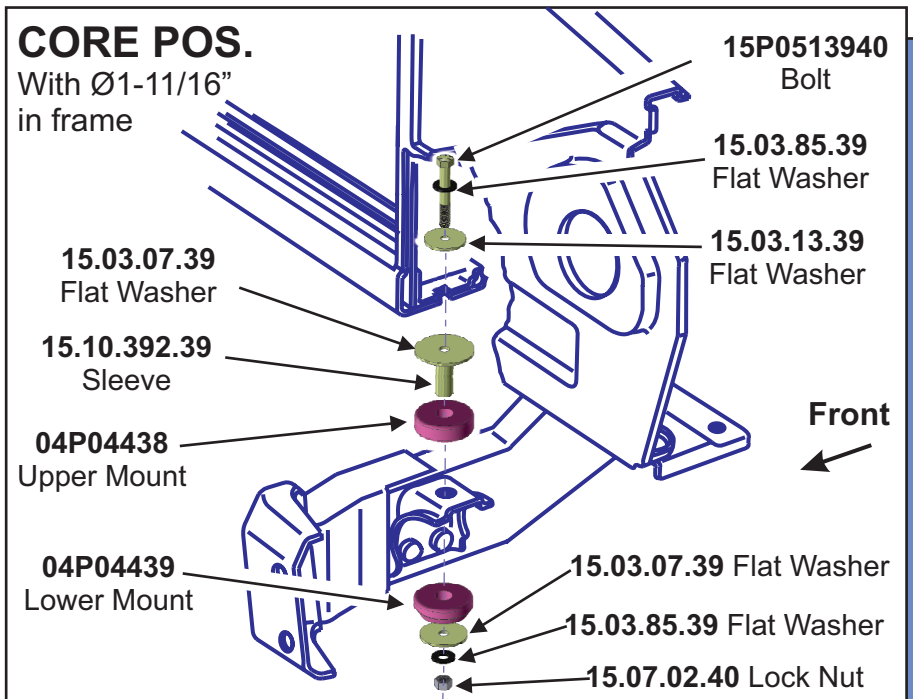

## POS. 1

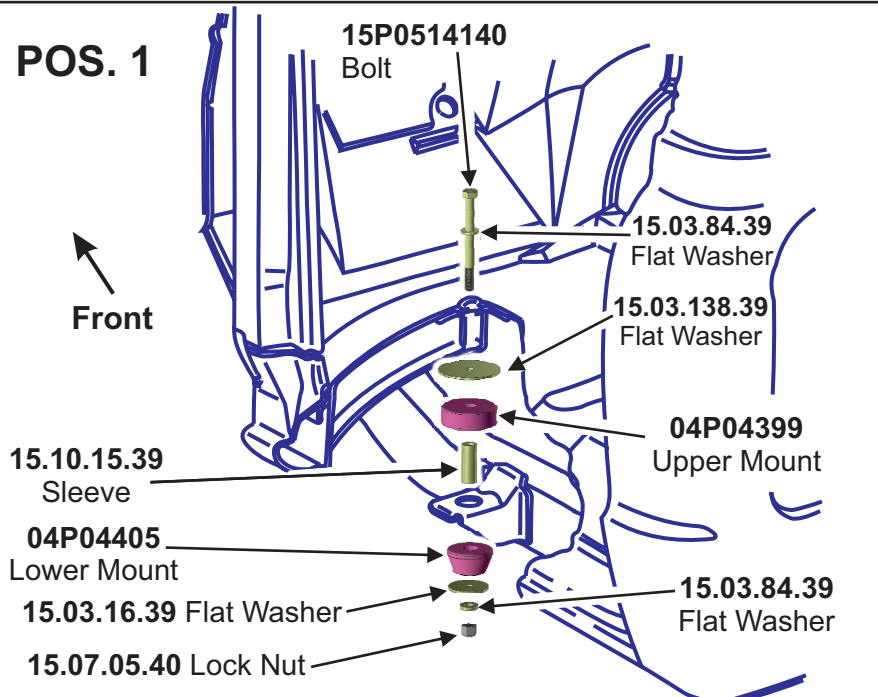

## POS. 2

