

Installation Instructions

Set # 3-4140

© 2002 Energy Suspension. All rights reserved.
 May not be reproduced, in any form, or by any means,
 without the written consent of Energy Suspension.



1131 VIA CALLEJON, SAN CLEMENTE, CA 92673

Removal

Spray all nuts to be removed generously with your favorite rust buster.

Note: When disassembling, note the quantity and positions of any shims that may have been inserted for body alignment. These shims will have to be reused to insure proper body alignment.

Remember: Only raise body high enough to remove & replace mounts. Always watch the fan shroud for sufficient clearance when raising the body. When jacking the body use a long enough 2X4 or 4X4 for maximum support. Never put jack directly on body panels.

Install mounts one side at a time with bolts on other side loosened only.

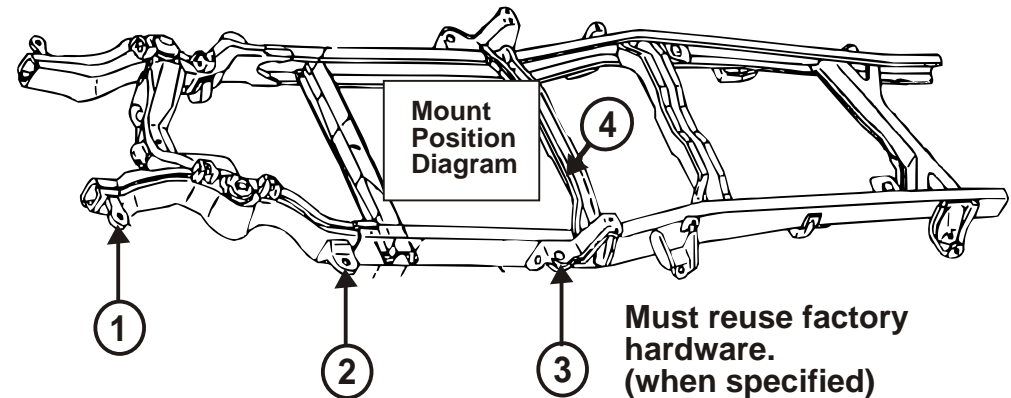

It is recommended that a factory service manual be purchased prior to performing any work on your car or truck.

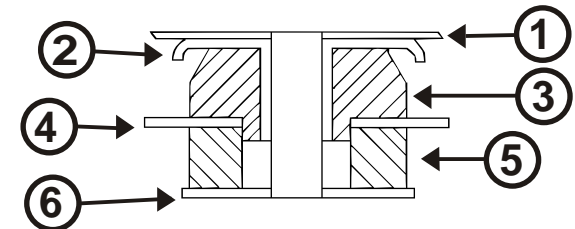

Parts Diagram
(your parts may vary)

POSITION #1	POSITION #2	POSITION #3	POSITION #4
1. Body	1. Body	1. Body	1. Body
2. Factory sleeve	2. Factory sleeve	2. Factory sleeve	2. Factory sleeve cut to 3 3/4"
3. 4115	3. 4010	3. 4059	3. 4008
4. Frame	4. Frame	4. Frame	4. Frame
5. 4114	5. 4011	5. 4114	5. 4009
6. Supplied washer	6. Supplied washer	6. Supplied washer	6. Supplied 2" washer (Install new bolts at this position)

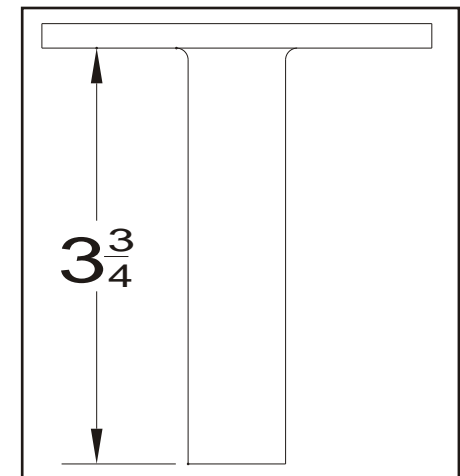

1. Kit comes with 4 conical shaped grommets, two of which have a larger I.D. than the other 2. The 2 large I.D. conicals (4009) fit the rear cab sleeves only.
2. The rear cab sleeves have to be shortened to a length of 3-3/4". The two bolts supplied will replace the O.E.M. bolts for the rear mounts only. The majority of these sleeves are heat treated, so cutting them with a conventional hacksaw may be difficult. Whether they are ground or flame cut, care must be taken on making a square cut to allow proper contact with the flat washer when final torque is applied. Torque spec. is 85 ft. lbs.
3. Positions 1,2,&3 do not need modifications to the factory sleeve. All mounting bolts should be checked periodically for proper torque.
4. The (2) 5" long bolts supplied are not for use on trucks that have body lift blocks. If your truck has a body lift kit you will need to use longer than 5" bolts. Example: If you have a 2" body lift, you will need 7" bolts. Bolts supplied with this kit are grade 5.

17114

BRH 8/NOV/99
 Updated 14/FEB/02 BRH