

Instruction sheet for set # 3.4110

67-72 Chevy K5 Blazer 4WD



1131 VIA CALLEJON, SAN CLEMENTE, CA 92673

It is recommended that if you are unfamiliar with this type of work that you refer to a qualified service center specializing in this type of work. It is also recommended that if you choose to do this work yourself that a factory service manual be obtained for the proper procedures pertaining to removal, replacement and proper torque specifications for your vehicle. This instruction set is intended as a guideline for the safe installation of Energy Suspension's polyurethane bushings, once you have removed the factory components from your vehicle.

© 2008 Energy Suspension. All rights reserved.
May not be reproduced, in any form, or by any means, without the written consent of Energy Suspension.

NOTE: When disassembling the body mounts, be sure to note the number and position of shims that may have been used to align the body. These shims will have to be reused to retain proper body alignment.

CAUTION: Remove all the body mount bolts on one side of the vehicle. Loosen but do not remove all the body mount bolts on the opposite side of the vehicle. Only raise one side of the vehicle at a time, lifting the body only high enough to remove/replace the mounts. Always watch the fan shroud, brake lines, and various hoses for sufficient clearance when raising the body. When jacking the body, use a 2x4 or equivalent to spread the weight. Never place jack faces directly on body panels! When all mounts and hardware are installed, torque all bolts to factory specifications.

17017
2/DEC/09 BRH

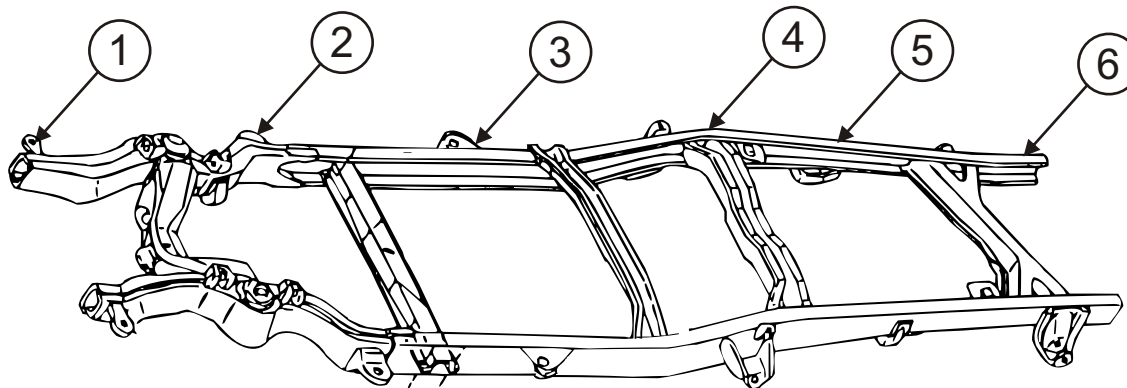

Parts Diagram

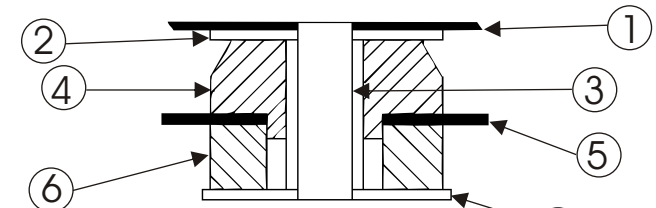

Must reuse original hardware
(When specified)

Position # 1

1. Core -support.
2. Supplied washer P/N 15.03.07.39.
(2-1/2" O.D. x 7/16" I.D. x 1/8")
3. Supplied sleeve P/N 15.10.17.39.
(7/8" O.D. x 5/8" I.D. x 1.960" lg.)
4. 4025 Top bushing.
5. Frame.
6. 4056 Lower bushing.
7. Supplied washer P/N 15.03.09.39.
(2" O.D. x 7/16" I.D. x 1/8")

Position #2

1. Body.
2. Supplied washer P/N 15.03.11.39.
(3" O.D. x 9/16" I.D. x 1/8")
3. Supplied sleeve P/N 15.10.50.39.
(7/8" O.D. x 11/16" I.D. x 1.80" Lg.)
4. 4053 Top bushing.
5. Frame.
6. 4055 Lower bushing.
7. Supplied washer P/N 15.03.05.39.
(2" O.D. x 1/2" I.D. x 1/8")

Position #3 - 6

1. Body.
2. Supplied washer P/N 15.03.11.39.
(3" O.D. x 9/16" I.D. x 1/8")
3. Supplied sleeve P/N 15.10.50.39.
(7/8" O.D. x 11/16" I.D. x 1.80" Lg.)
4. 4054 Top bushing.
5. Frame.
6. 4056 Lower bushing.
7. Supplied washer P/N 15.03.06.39.
(2" O.D. x 3/8" I.D. x 1/8")