

Set # 3-3152 & Set # 3-3153

Must use existing outer metal shells.
Lubricate sleeves, bushings and I.D. of shells with supplied grease.
Install bushings in shell, then install sleeve in bushing.
Thrust washers are installed over shell area opposite of flange

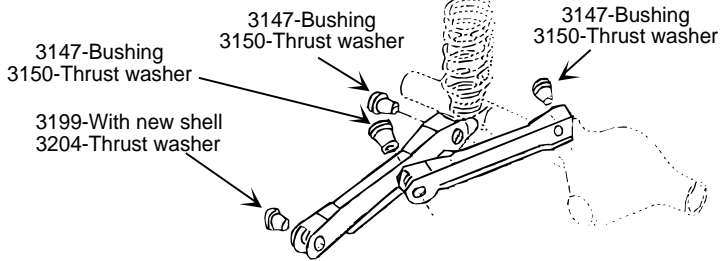

The thrust washers are designed to prevent the control arm from walking side-to-side by accepting side load pressure created during hard cornering. Most kits contain more than one part #. It is very important to install them at the correct location.
See illustration

ENERGY SUSPENSION

1131 VIA CALLEJON, SAN CLEMENTE, CA 92673

© 2002 Energy Suspension. All rights reserved.
May not be reproduced, in any form, or by any means, without the written consent of Energy Suspension.

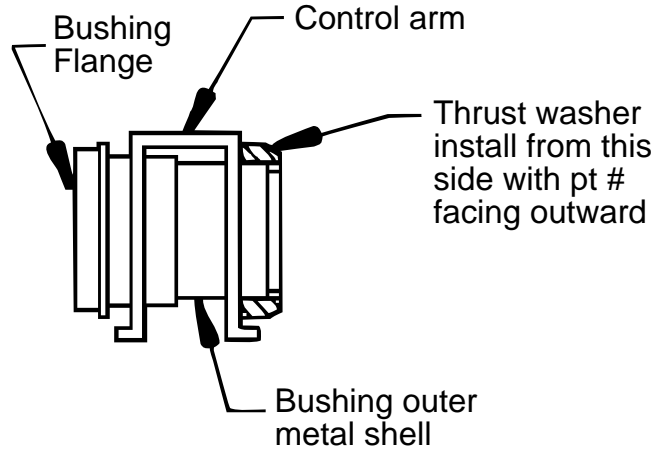

17088

3/26/97 KN
Updated 18/JAN/02 BRH

Set # 3-3152 & Set # 3-3153

Must use existing outer metal shells.
Lubricate sleeves, bushings and I.D. of shells with supplied grease.
Install bushings in shell, then install sleeve in bushing.
Thrust washers are installed over shell area opposite of flange

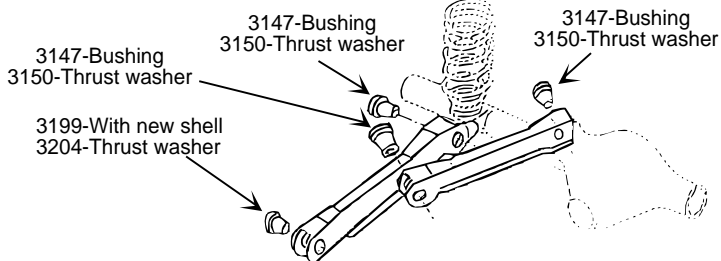

The thrust washers are designed to prevent the control arm from walking side-to-side by accepting side load pressure created during hard cornering. Most kits contain more than one part #. It is very important to install them at the correct location.
See illustration

ENERGY SUSPENSION

1131 VIA CALLEJON, SAN CLEMENTE, CA 92673

© 2002 Energy Suspension. All rights reserved.
May not be reproduced, in any form, or by any means, without the written consent of Energy Suspension.

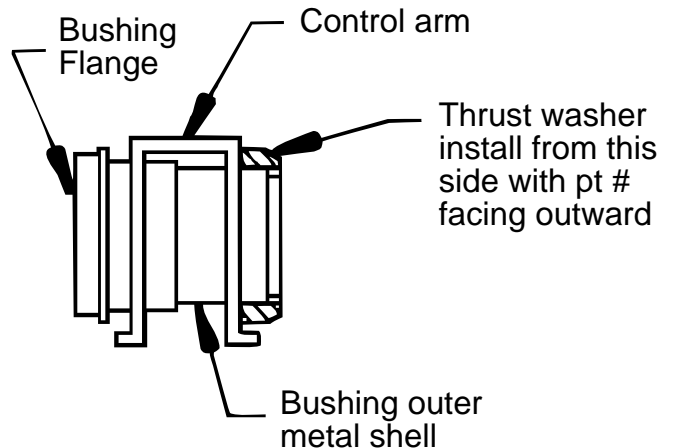

17088

3/26/97 KN
Updated 18/JAN/02 BRH