

Set # 3-1145

1982-93 S-10, S-15 Pickup Blazer, Jimmy 2.8L V6 2WD & 4WD motor mount insert



1131 VIA CALLEJON, SAN CLEMENTE, CA

It is recommended that if you are unfamiliar with this type of work that you refer to a qualified service center specializing in this type of work. It is also recommended that if you choose to do this work yourself that a factory service manual be obtained for the proper procedures pertaining to removal, replacement and proper torque specifications for your vehicle. This instruction set is intended as a guideline for the safe installation of Energy Suspension's polyurethane bushings, once you have removed the factory components from your vehicle.

**ENERGY SUSPENSION Recommends
Replacing both left and right side
mounts at the same time.**

Raise vehicle to suitable height and support properly to allow easy access to the engine mounting locations. **NOTE: BE SURE VEHICLE IS SECURELY SUPPORTED BEFORE GOING UNDERNEATH.** Before loosening the motor mount bolts, find a suitable jacking location near the front of the engine block. Do not lift on crankshaft pulleys or oil pan. Severe damage could occur to these components. If available, use an engine hoist to raise engine. Raise the engine to a height necessary to remove load from the engine mounts. Remove the 4-1/2" long engine mounting bolt. Raise the engine again to allow enough clearance between the engine mounting bracket and motor mount. **NOTE: BE CAREFUL NOT TO CAUSE DAMAGE TO OTHER ENGINE COMPONENTS BY RAISING THE ENGINE TOO HIGH, ie, DISTRIBUTOR CAP ON FIREWALL, FAN, etc.** Remove bolts securing motor mount to cross member. It may be necessary to remove lower control arms to gain access to inside of cross member to hold the nuts. Remove motor mount from the vehicle and inspect the metal shells for damage. **NOTE: THE OUTER METAL SHELLS MUST BE REUSED, IT IS VERY IMPORTANT THAT THE METAL SHELLS BE UNDAMAGED.**

STEP - 1

Using a 7/16" drill bit, drill out the three formed rivets that hold the two metal shells together. Drill down just enough to remove rivet material to allow the metal shells to be separated. **CAUTION**, the rubber insert is compressed and will cause the metal shells to separate abruptly. After separation, remove any burrs or sharp edges from the drilled out holes.

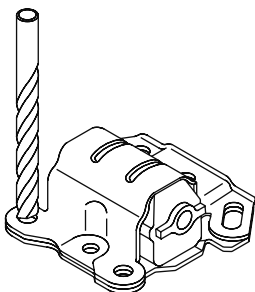

Clean any dirt and grease that may have accumulated inside the metal shells. **NOTE: IT IS VERY IMPORTANT THAT THE INSIDE OF THE METAL SHELLS BE CLEAN.** At this point, it is your option to have your metal painted, powder coated, or chromed.

When reassembling motor mounts, **pay very close attention** to the diagrams showing proper assembly procedure. This motor mount insert can go into the metal shells two ways; the right way, and the wrong way. Be sure to follow the instructions carefully so that you do it the right way!

STEP - 2

Position the polyurethane insert into the top metal shell so that the circular shaped recess in the side of the insert aligns with the circular shaped hump on the side of the metal shell. Make sure the grooves on the bottom of the insert set on the formed metal humps on the bottom metal shell. Position the grooves on the top metal shell onto the grooves on the top of the insert, making sure that all bolt holes are lined up.

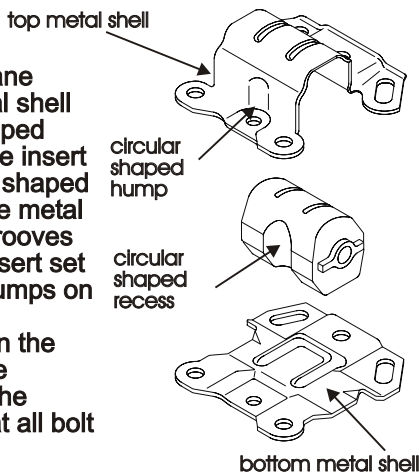

HINT: Due to the many different metal configurations from foreign and domestic manufacturers it maybe helpful to apply a thin coating of grease or dishwashing detergent to the polyurethane insert, at metal contact points before installing. This will allow the insert to seat, in turn allowing proper bolt alignment.

STEP - 3

Place the assembly into a vise or large clamp, leaving access to the drilled out holes. Use enough clamping force to hold the two metal shells together, without permanently deforming the metal (a slight amount of metal bending may occur, this is normal). To temporarily hold the assembly together, use the three tie-wraps provided inserting them through the drilled holes, from the bottom, as shown. Tighten the tie-wraps securely, taking care not to break them.

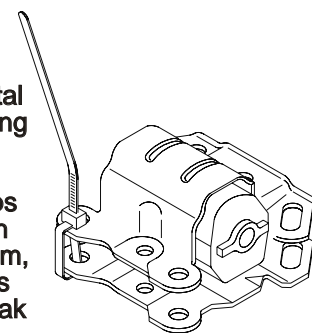

Make sure the tie-wraps are holding firm while releasing the clamp or vise. Cut the ends of the tie-wraps off, being sure not to leave any sharp edges. The metal shells may separate slightly, this is normal. However, excessive separation will cause the mounting bolts not to reach through the cross-member and not allow the nuts to be started on the bolts.

STEP - 4

Reassemble motor mount into engine compartment, leaving all bolts loosened until the 4-1/2" long bolt going through the brackets have been installed. Tighten all bolts to factory specs. If so desired, you may remove the remaining portion of the tie-wraps.

NOTE: The ENERGY SUSPENSION Polyurethane motor mount insert will restore your engine to its original height. If adjustments have been made to other engine components, such as, fan shroud, fuel lines, etc. due to sagging, worn motor mounts, these components will need to be readjusted back to their original locations. **Also, be sure to check hood clearance before closing.**

© 2005 Energy Suspension. All rights reserved.
May not be reproduced, in any form, or by any means,
without the written consent of Energy Suspension.