

Set # 2-4102 and 2-4104

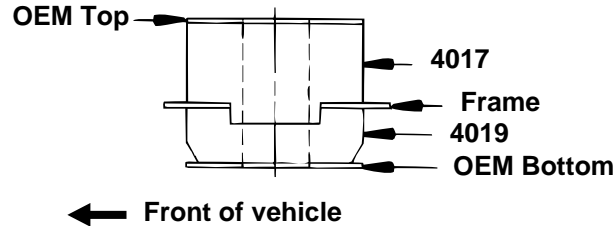

1131 VIA CALLEJON, SAN CLEMENTE, CA 92673

POSITION # 1



Must re-use original hardware.

OEM Top

POSITION # 2-4-5-6

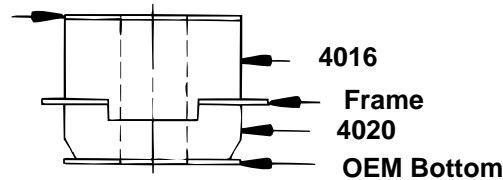

POSITION # 3

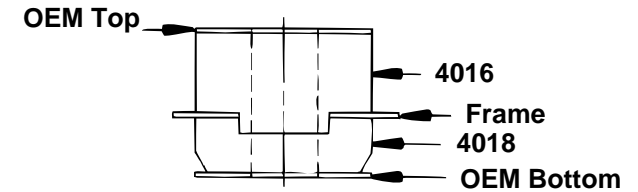

Removal

Spray all nuts to be removed generously with your favorite rust buster.

Note: When disassembling, note the quantity and positions of any shims that may have been inserted for body alignment. These shims will have to be reused to insure proper body alignment.

Remember: Only raise body high enough to remove & replace mounts. Always watch the fan shroud for sufficient clearance when raising the body. When jacking the body use a long enough 2X4 or 4X4 for maximum support. Never put jack directly on body panels.

Install mounts one side at a time with bolts on other side loosened only.

Retorque to factory specs.

One extra mount used on CJ8
4016 and 4020

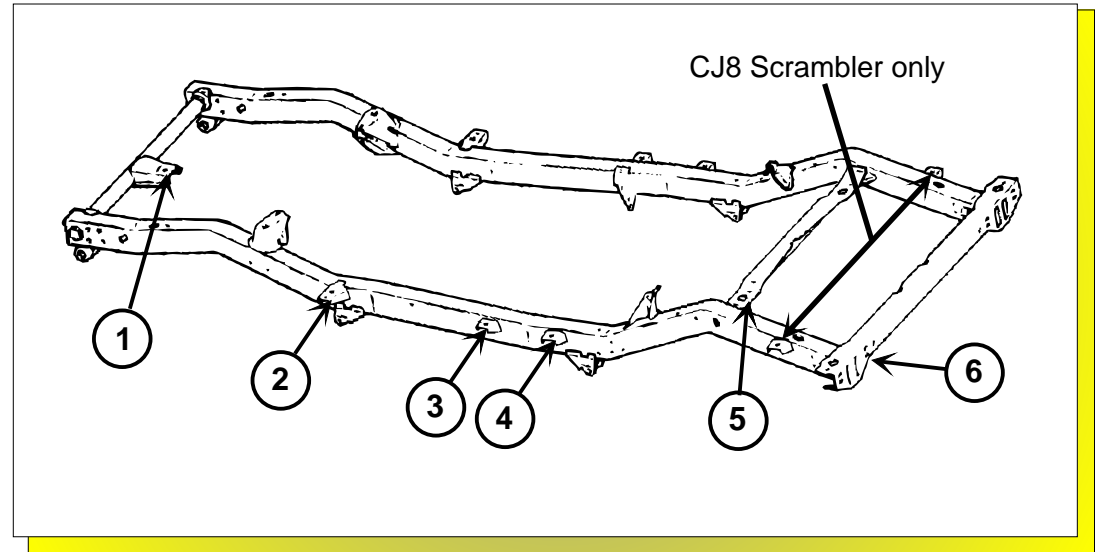

© 2002 Energy Suspension. All rights reserved.
May not be reproduced, in any form, or by any means,
without the written consent of Energy Suspension.

Note: It is recommended that this set be professionally installed if you are unfamiliar with this type of work, and a factory service manual be purchased prior to performing any work on your vehicle for proper disassembly, reassembly and torque specs. These instructions are intended for bushing removal and install of Energy Suspension polyurethane bushings, once you have removed the factory component from your vehicle.