

This instruction is intended as a guideline for the safe installation of Energy Suspension polyurethane bushings after original equipment has been removed from the vehicle. It is recommended that you utilize a qualified service center for the replacement of these components if you are unfamiliar with vehicle chassis and suspension repair work. Reference vehicle manufacturer's service manual for component removal and replacement procedures and torque specifications. Before beginning work, read these instructions thoroughly and verify that parts received match P/N's and quantities in parts list. In the case of discrepancy, contact Energy Suspension Customer Service (949-361-3935). Because wheel alignment is altered when suspension components are removed and replaced, it is highly recommended that your vehicle be checked and adjusted by a qualified alignment shop prior to use. Energy Suspension parts are designed to work with vehicles in good state of repair. We cannot be held responsible for suspension or steering related problems occurring due to poor vehicle maintenance.

PARTS LIST

<u>QTY:</u>	<u>P/N:</u>	<u>DESCRIPTION:</u>
2	03P03613	INNER POLYURETHANE BUSHING
2	03P03614	OUTER POLYURETHANE BUSHING
2	15P0511940	BOLT, SLOTTED, M16-1.5 X 100mm
2	15P0315839	WASHER, 1.312" X .656" X .122"-.146"
2	15P1212839	SLEEVE, 1.125" O.D. X .640" OFFSET I.D. X 2.615" WITH SET SCREWS

NOTE: REUSE ORIGINAL NUT

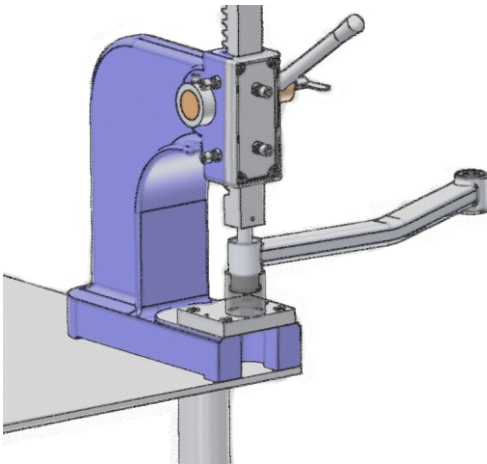

1. Prepare for Installation

Remove one front lower control arm from vehicle and press out rubber bushing from axle end.

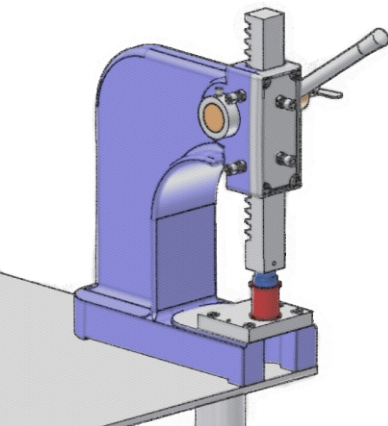

2. Pre-Assemble Bushing

Press inner polyurethane bushing into outer polyurethane bushing. DO NOT USE GREASE.

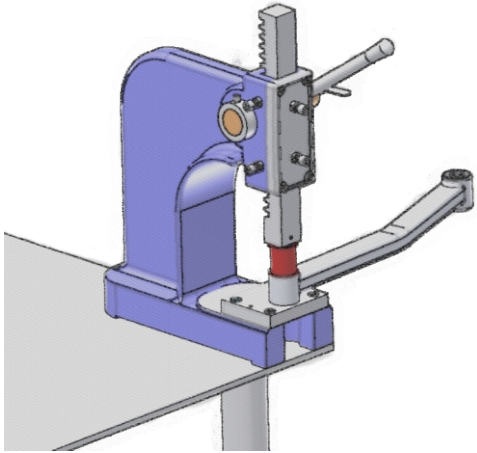

3. Install Bushing Pair into Control Arm.

Use your hand or guide cone to squeeze bushing flange into control arm eyelet while pressing down with press. Once installed, ensure that bushing is centered in arm and that bushing flanges are evenly exposed. **DO NOT USE GREASE.**

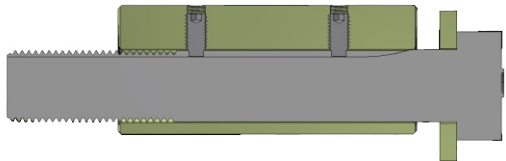

CUTAWAY VIEW

4. Position Set Screws.

Insert slotted bolt into offset I.D. sleeve. Align groove of bolt with set screws. Tighten set screws using 3/32" allen wrench until they contact bolt. Back them out 1/4 turn. Bolt should easily slide in and out.

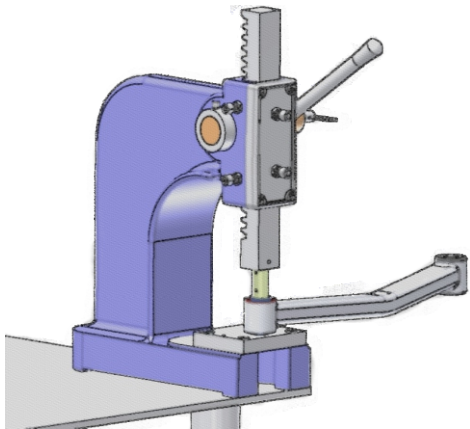

5. Install Sleeve.

Grease I.D. of inner polyurethane bushing and O.D. of sleeve. Press sleeve into bushing until centered. Wipe off any remaining grease on sleeve and ensure that none remains in sleeve I.D.

6. Install Control Arm in Vehicle

Position rear end of arm into vehicle frame; then front end of arm into axle. Insert bolt and install locknut. For maximum caster angle, rotate bolt head to orient offset I.D. toward rear of vehicle. Torque fasteners to factory specification.

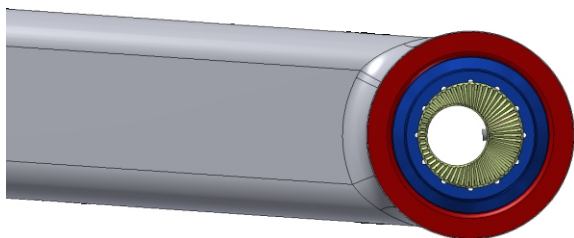

FRONT →

Repeat process with other control arm.