

Installation Instructions

for Set # 16.3115

99-00 Honda Civic Si



1131 VIA CALLEJON, SAN CLEMENTE, CA 92673

It is recommended that if you are unfamiliar with this type of work that you refer to a qualified service center specializing in this type of work. It is also recommended that if you choose to do this work yourself that a factory service manual be obtained for the proper procedures pertaining to removal, replacement and proper torque specifications for your vehicle. This instruction set is intended as a guideline for the safe installation of Energy Suspension's polyurethane bushings, once you have removed the factory components from your vehicle.

1. Properly support the vehicle on the frame. Remove the upper control arm assembly from the vehicle (see diagram).
2. Remove the rubber bushing, DO NOT REMOVE O.E. OUTER METAL SHELL FROM UPPER CONTROL ARM. Grease all sides of the bushing that contact metal. Press in the Energy Suspension bushing. Note: On the upper control arm, the bushings have a part number engraved in them. The P/N 3371 on each bushing must be facing away from each other. (see diagram). Grease and install the sleeve.
3. Reinstall the upper control arm assembly onto the vehicle.
4. Unbolt the rear mount from the lower control arm. Remove the rubber bushing and sleeve from the mount. Remove the lower control arm. Press out the rubber bushing and shell (front position) from the control arm.
5. Grease the I.D. of the lower control arm (where the shell was). Grease all sides of the bushing that will contact metal.
6. Install the bushings. The rear mount bushing needs to be installed so that the part number engraved on the bushing is facing toward the rear of the vehicle. (See diagram). Grease the I.D. of bushing, sleeve, and inner face of washer.
7. Reassemble the lower control arm onto the vehicle. Tighten all fasteners to factory specs.
8. After installation is complete, Energy Suspension recommends a alignment be performed at a qualified alignment shop.

Other Energy Suspension sets available for this vehicle:

16.7106	Rear trailing arm bushing set
16.8111	Front shock bushing set
16.6103	Front spring isolator set
16.13101	Ball joint boot set
9.13103	Tie-rod boots
16.1101	Manual trans. shifter stabilizer
16.5130	Front sway bar bushings (26mm)

© 2004 Energy Suspension. All rights reserved.
May not be reproduced, in any form, or by any means, without the written consent of Energy Suspension.

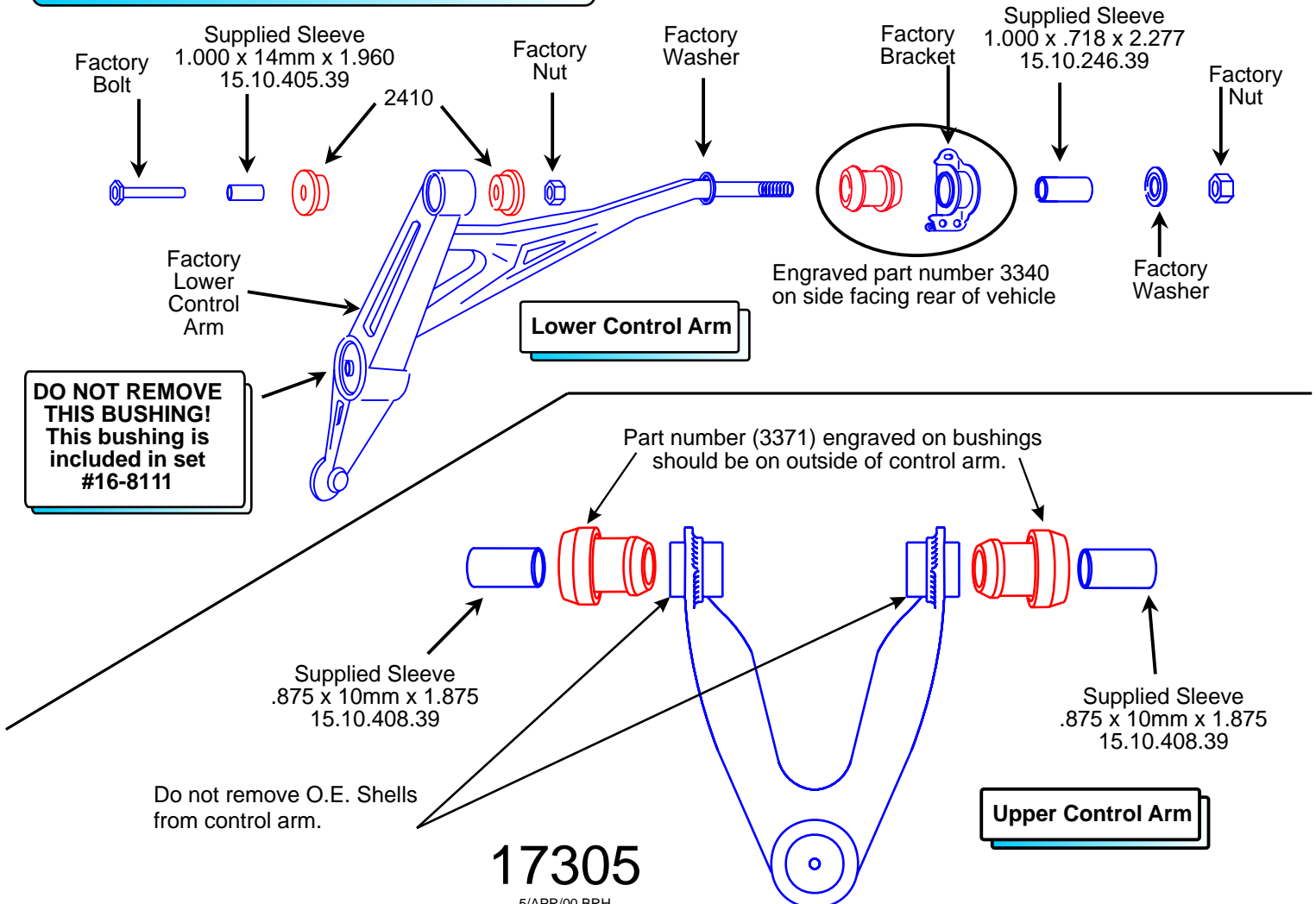

17305

5/APR/00 BRH
Updated 13/APR/04 BRH
Updated 26/AUG/04 BRH