

Installation instructions

For set # 11.3103
86-91 Mazda RX7

ENERGY
SUSPENSION 

1131 VIA CALLEJON, SAN CLEMENTE, CA 92673

© 2006 Energy Suspension. All rights reserved.
May not be reproduced, in any form, or by any means,
without the written consent of Energy Suspension.

It is recommended that if you are unfamiliar with this type of work that you refer to a qualified service center specializing in this type of work. It is also recommended that if you choose to do this work yourself that a factory service manual be obtained for the proper procedures pertaining to removal, replacement and proper torque specifications for your vehicle. This instruction set is intended as a guideline for the safe installation of Energy Suspension's polyurethane bushings, once you have removed the factory components from your vehicle.

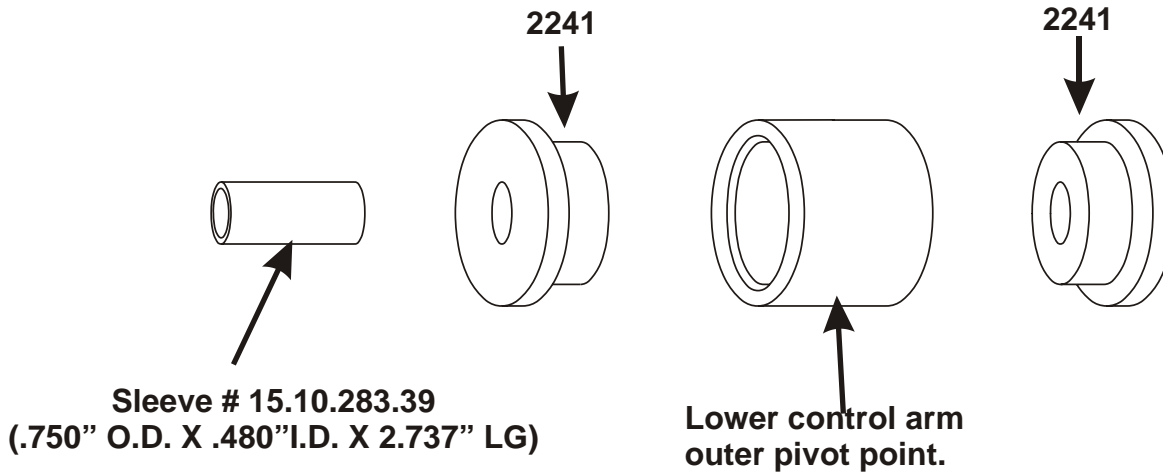

1. Remove the rear control arm from the vehicle.
2. Press out the two factory bushings (including shells) from the outer control arm pivot being careful not to scar the inside of the control arm.
3. Grease all surfaces that will contact metal.
4. Press the urethane bushings into the barrel of the control arm. Grease all remaining exposed parts of the bushing thoroughly.
5. Reinstall the control arm back into the vehicle.
6. Torque all fasteners to factory specs.

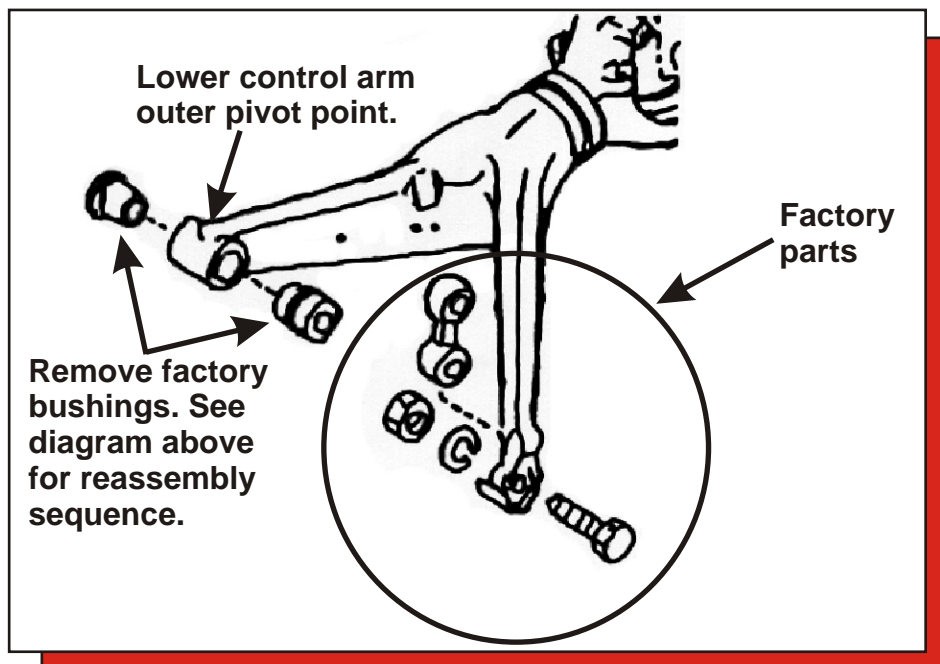

17125

18/JUL/06 BRH