



INSTALLATION GUIDE: AWE EXHAUST SUITE FOR THE BMW G2X 330I/430I

For up-to-date fitment information, please visit the product page on [AWE-Tuning.com](https://www.awe-tuning.com).

THIS GUIDE IS INTENDED FOR THE FOLLOWING PART NUMBERS:

- 3015-32429 AWE Touring Edition Axle Back Exhaust for BMW G2X 330i/430i - Chrome Silver
- 3015-33429 AWE Touring Edition Axle Back Exhaust for BMW G2X 330i/430i - Diamond Black
- 3020-32429 AWE Track Edition Axleback Exhaust for BMW G2X 330i/430i - Chrome Silver
- 3020-33429 AWE Track Edition Axleback Exhaust for BMW G2X 330i/430i - Diamond Black

Welcome to the AWE family, and congratulations on your purchase of the AWE Exhaust System for the BMW G2X 330i/430i.

Exquisite build quality and craftsmanship, coupled with industry leading performance, distinguish this exhaust system from all others.

*For up to the minute fitment information, be sure to visit the AWE website. As always, AWE Performance Specialists are standing by for any questions, [right here](#).

PARTS LIST (TOURING SYSTEMS)



Inspect **ALL** parts prior to disassembly of vehicle; If damaged or **MISSING**, please contact the place of purchase immediately.

Symbol	Part Number	Description	QTY
	F09	BMW G2X 330/430 Axle Back Inlet Tube	1
	F11	BMW G2X 330/430 Track/Touring Tip Outlet DS/PS	2
	F12	BMW G2X 330/430 Touring Rear Section Assembly	1
A >>	18_30_7_560_782	85mm Sleeve Clamp	1
B >>	180300	3.00" Band Clamp	3
C >>	3910-41010	Hardware Kit for Integrated Clamp Style Exhaust Tips	1
D >>	3910-11034	3/8" CLAMP-KIT	1
E >>	150004	SBS Valve Motor Simulator	1
F >>	98380A457	416 Stainless Steel Dowel Pins, 7/64" Diameter, 1" Long	1
G >>	7130K56	14" Cable Tie	2
H >>	180014	AWE 4.5" Slash Cut Chrome Silver Tip	2
H >>	180015	AWE 4.5" Slash Cut Diamond Black Tip	2

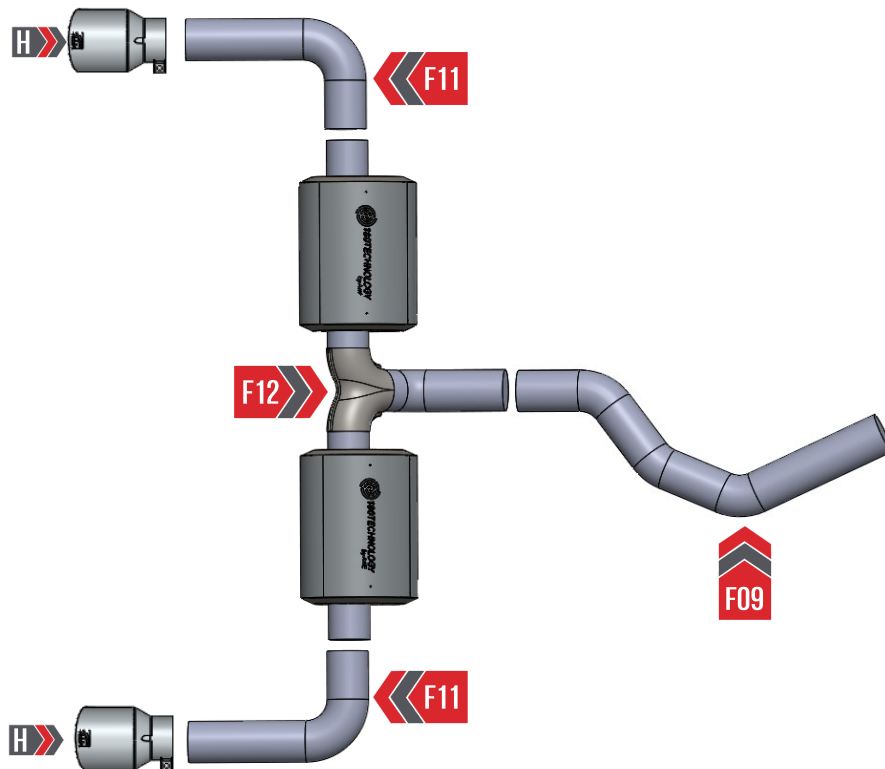

PARTS LIST (TRACK SYSTEMS)



Inspect **ALL** parts prior to disassembly of vehicle; If damaged or **MISSING**, please contact the place of purchase immediately.

Symbol	Part Number	Description	QTY
	F09	BMW G2X 330/430 Axle Back Inlet Tube	1
	F10	BMW G2X 330/430 Track Rear Section Assembly	1
	F11	BMW G2X 330/430 Track/Touring Tip Outlet DS/PS	2
A	18_30_7_560_782	85mm Sleeve Clamp	1
B	180300	3.00" Band Clamp	3
C	3910-41010	Hardware Kit for Integrated Clamp Style Exhaust Tips	1
D	3910-11034	3/8" CLAMP-KIT	1
E	150004	SBS Valve Motor Simulator	1
F	98380A457	416 Stainless Steel Dowel Pins, 7/64" Diameter, 1" Long	1
G	7130K56	14" Cable Tie	1
H	180014	AWE 4.5" Slash Cut Chrome Silver Tip	2
	180015	AWE 4.5" Slash Cut Diamond Black Tip	2

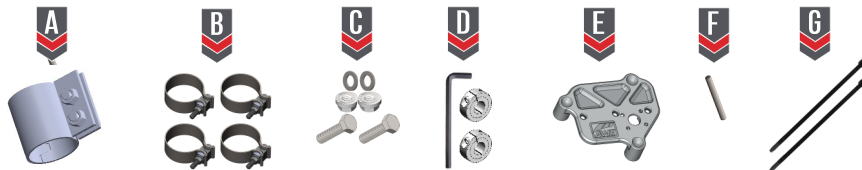
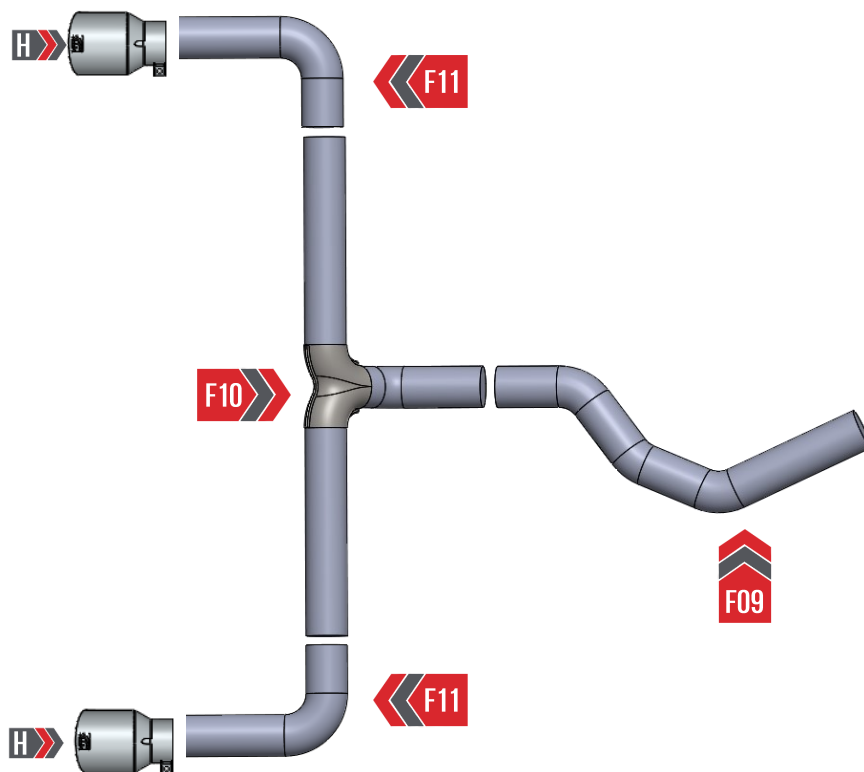



NOTE: Always refer to the manufacturer's service manual for precise torque specifications on all OEM fasteners.



CAUTION: The exhaust may be **VERY HOT** — allow adequate time for the system to cool down before disassembly. Severe burns and injury will occur if skin comes into contact with a hot exhaust system.

STEP 1



Soak all bolts and rubber hangers in penetrating oil before starting any work.

1. Begin by locating the dimple (**A**) in front of the balancer, as shown in **Figure 1-1**, and **Figure 1-2**. Make a straight cut on the dimple. Cut as straight as possible. Debur inside, and out.
2. Unplug the valve as shown at (**B**) in **Figure 1-2**.
3. Remove the OE rubber hanger (**C**) shown in **Figure 1-2**.
4. Unbolt the hangers (**D**) as shown in **Figure 1-2**. The OE exhaust will be complete free to be removed after these hangers are unbolted.

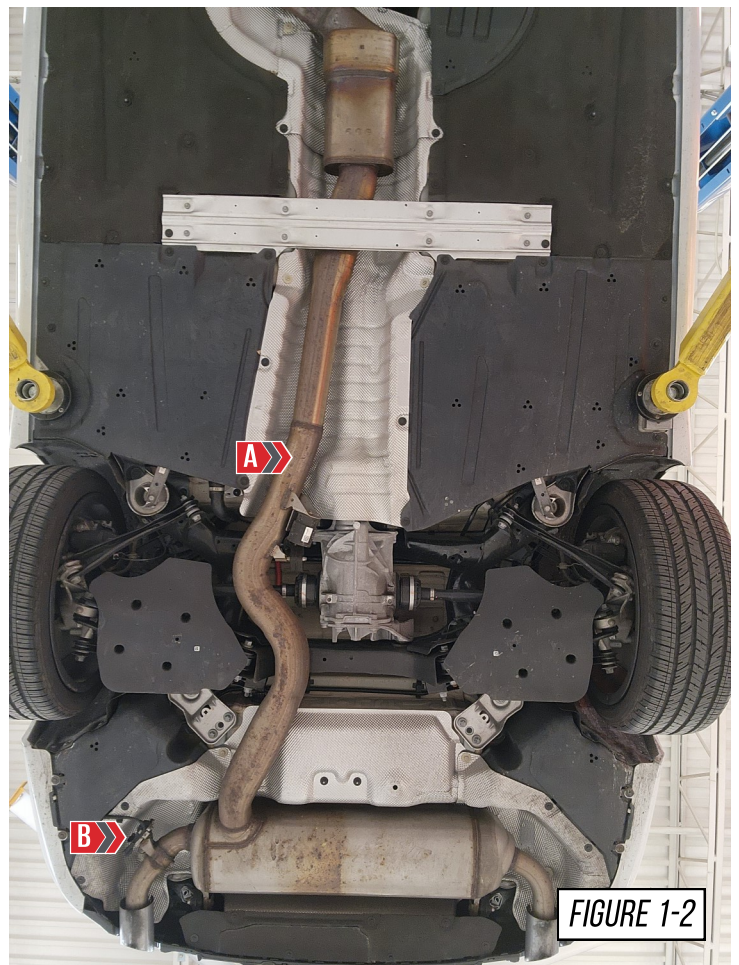
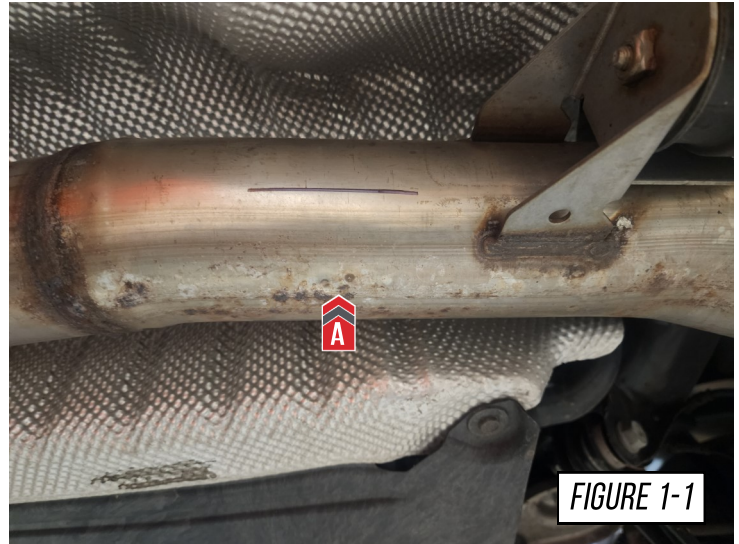

STEP 2

Remove the four fasteners that hold the plastic shroud in place, as shown at (A) in **Figure 2**, this will allow you to remove the plastic shroud.

Note: The plastic shroud will be reinstalled later.

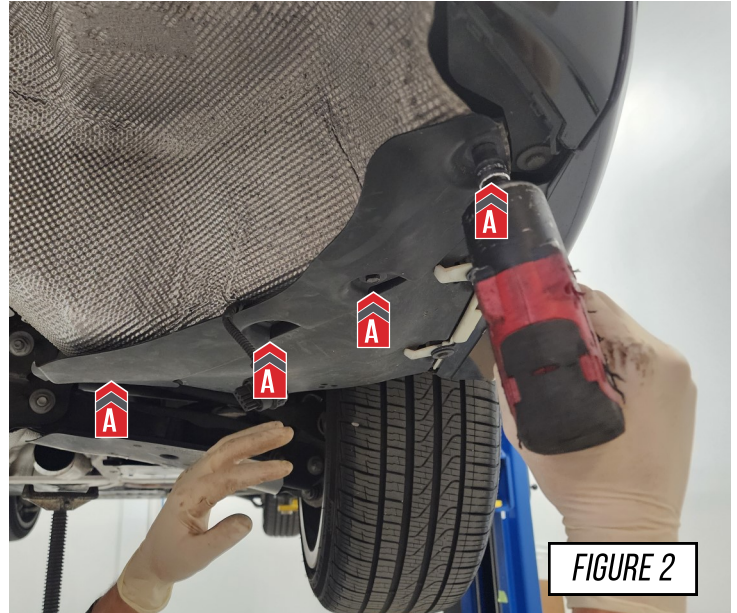

STEP 3

Remove the three fasteners that hold the heat shield in place, as shown at (A) in **Figure 3**, this will allow you to remove the heat shield.

Note: If your car is equipped with a plastic shield that will also be removed in this step

Note: The heat shield will be reinstalled later, the plastic shield will not be reinstalled.

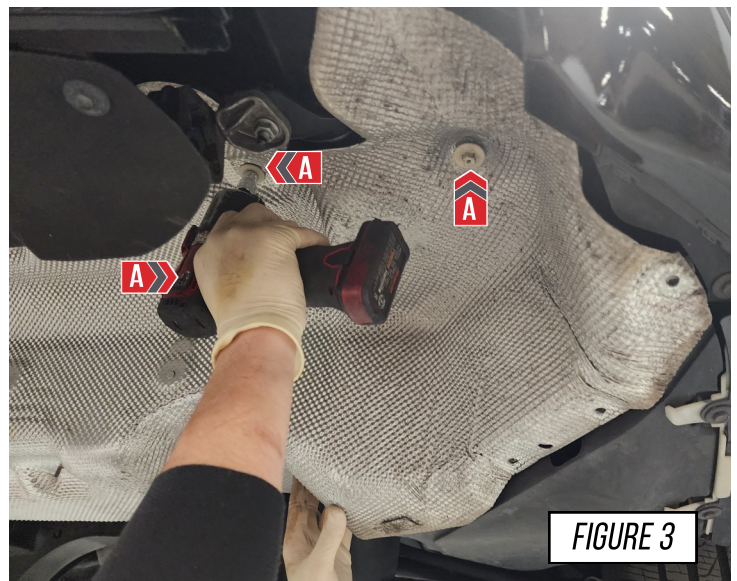

STEP 4

Remove the OE valve from the OE exhaust system.

Next gather your valve motor simulator (**A**) and your dowel pin (**B**). Place the dowel pin in the cut out on the bucket shown in **Figure 4**.



STEP 5

To ensure you have the valve simulator aligned correctly, flip it over and verify that the dowel is resting in the cut out of the valve motor pin, as shown in **Figure 5**.

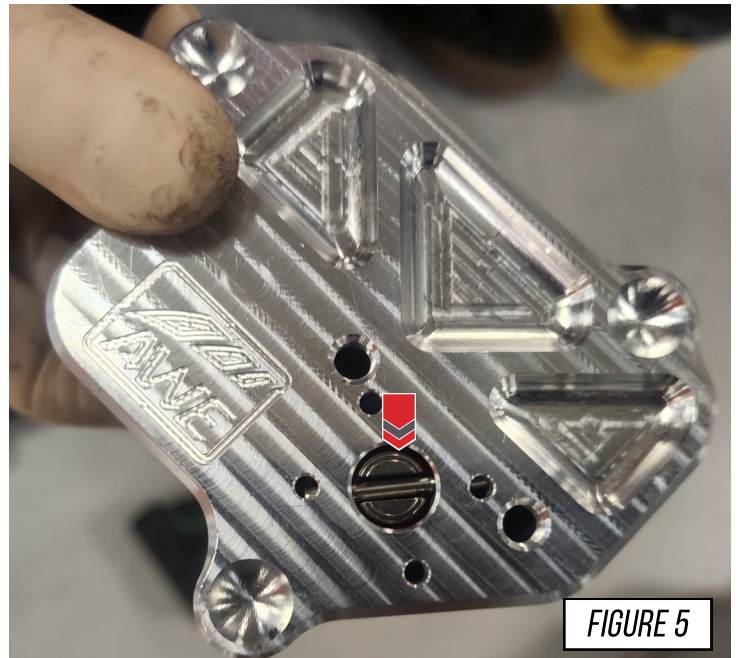

STEP 6

Using the OE hardware that was removed earlier, secure the valve motor to the AWE valve simulator bracket, as shown in **Figure 6**.

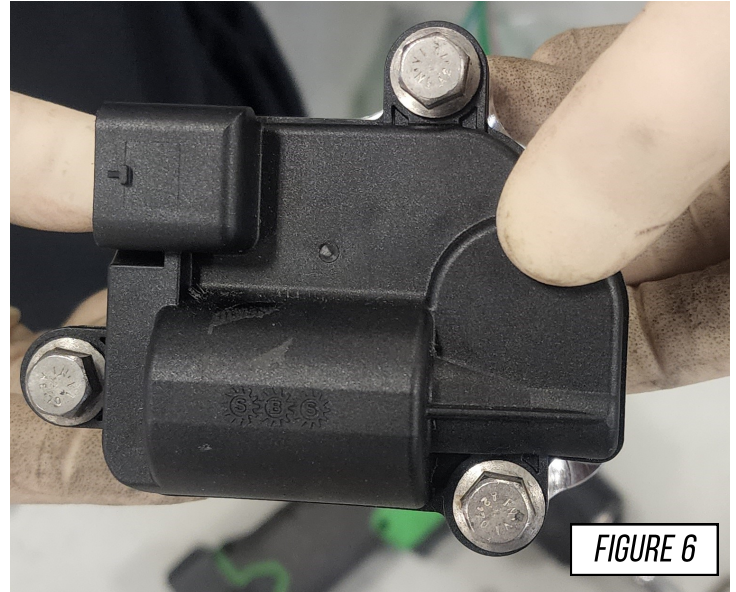

STEP 7

Install your AWE valve simulator assembly using a provided cable tie. Secure the AWE valve simulator to the plastic bracket in the cavity beneath the heat shield, as shown in **Figure 7**.

At this point you can reinstall the OE heat

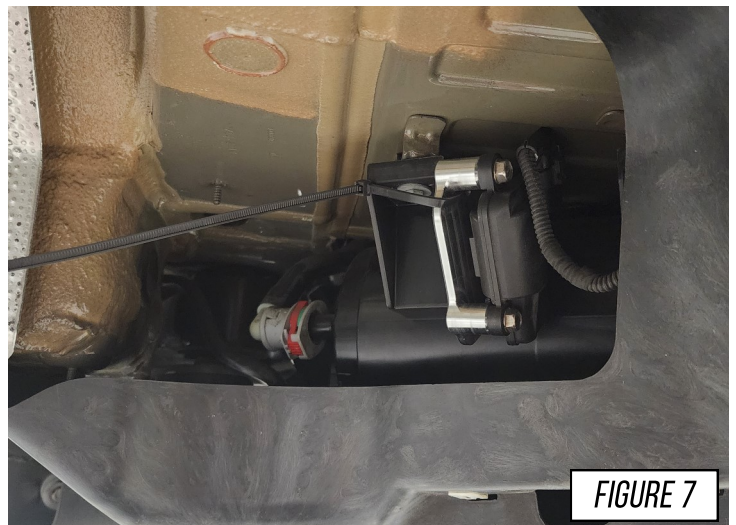

STEP 8

Gather the provided sleeve clamp (**A**), and slide it over the cut point on the OE exhaust.

Next install your AWE axle back inlet tube (**F09**), as shown in **Figure 8**. First slide the hanger bar into the OE hanger, then bottom out the slip joint, over the OE exhaust tube.

Snug the clamp but do not fully tighten it at this time.

Note: Ensure the AWE axle back inlet tube is completely bottomed out on the OE exhaust tube.

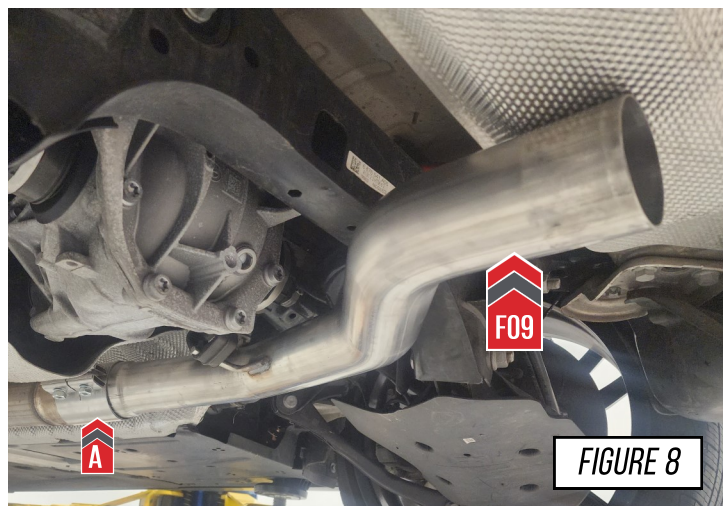

STEP 9

Adjust the AWE axle back inlet tube (**F09**) so there is adequate clearance from the heat shield, as shown in **Figure 9**.

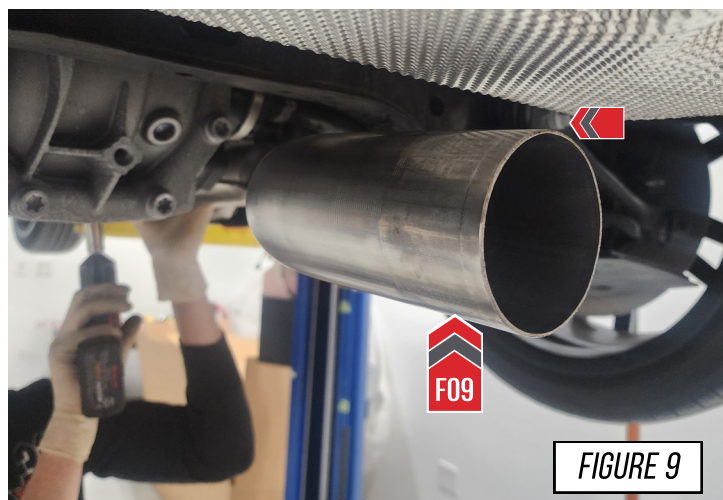

STEP 10

It is crucial to install each section and exhaust band clamps correctly to prevent loose joints, exhaust leaks and rattles.

Arrow A shows the expanded pipe and the preinstalled exhaust clamp being brought up to the corresponding pipe.

Arrow B shows the overlapping pipe installed correctly over the corresponding pipe.

Arrow C shows the exhaust band clamp being brought to the edge of the expanded pipe.



NOTES:

- **Do not** fully torque any exhaust clamp until the entire exhaust has been installed and adjusted.
- Torque specification is a **minimum** of 60 ft/lbs

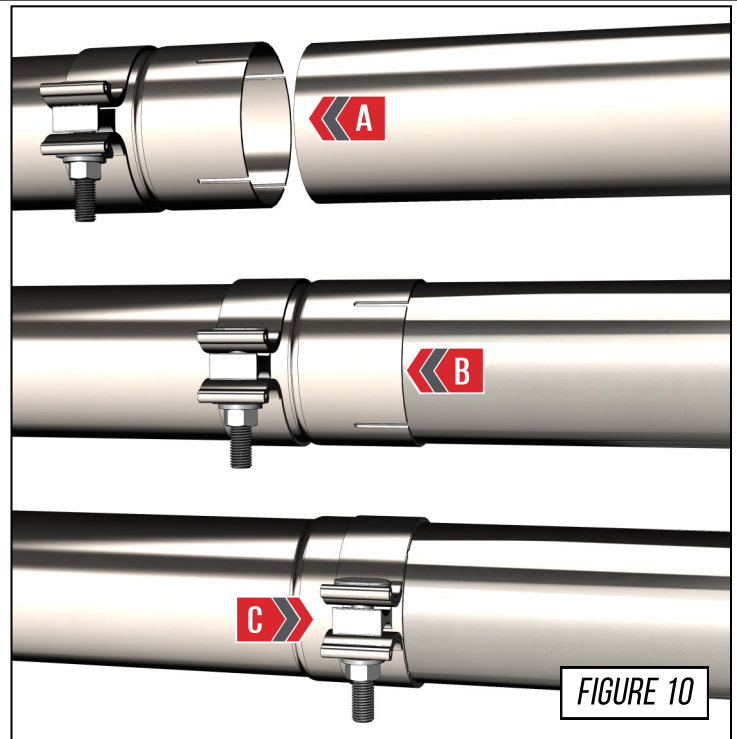

STEP 11



Step 11 is for Track systems only.

Install your AWE Track rear section (**F10**), as shown in **Figure 10**. Slide a provided clamp over the inlet of the rear section.

Next slide both hanger bars into the OE hangers (**A**) then bottom out the slip joint on the AWE axle back inlet tube (**F09**).

Snug the clamp, but do not fully tighten it at this point

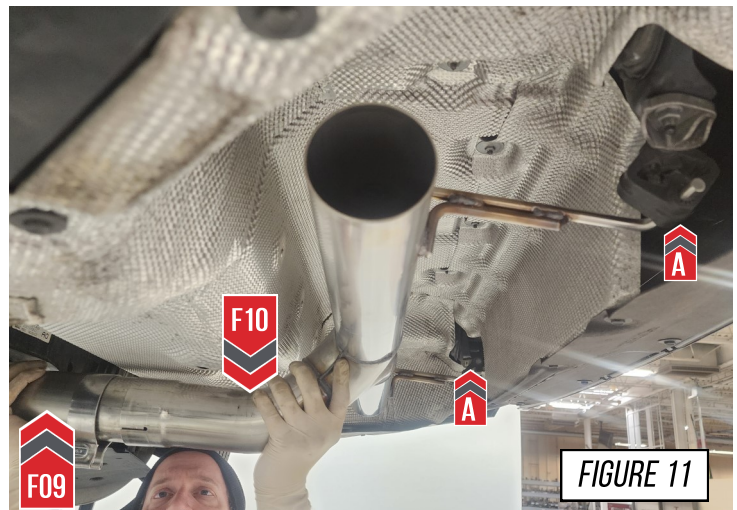

STEP 12



Step 12 is for Touring systems only.

Install your AWE Touring rear section (**F12**), as shown in **Figure 12**. Slide a provided clamp over the inlet of the rear section.

Next slide both hanger bars into the OE hangers (**A**) then bottom out the slip joint on the AWE axle back inlet tube (**F09**).

Snug the clamp, but do not fully tighten it at this point

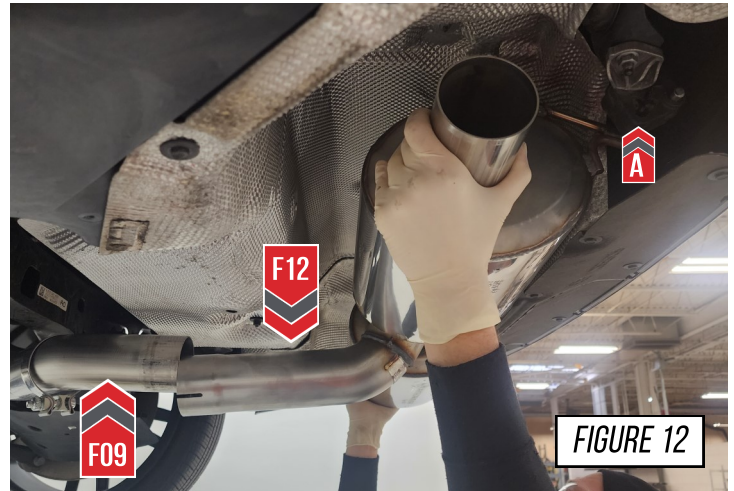

STEP 13

Install your AWE tip outlets (**F11**) on to your respective rear section (**F10/F12**), as shown in **Figure 13-1**. and **Figure 13-2**.

Slide a provided clamp over each tip outlet, then bottom out the slip joint on the rear section.

Align the tip outlet with the cutout in the rear valance, and snug the clamp. Do not fully tighten the clamp at this time.

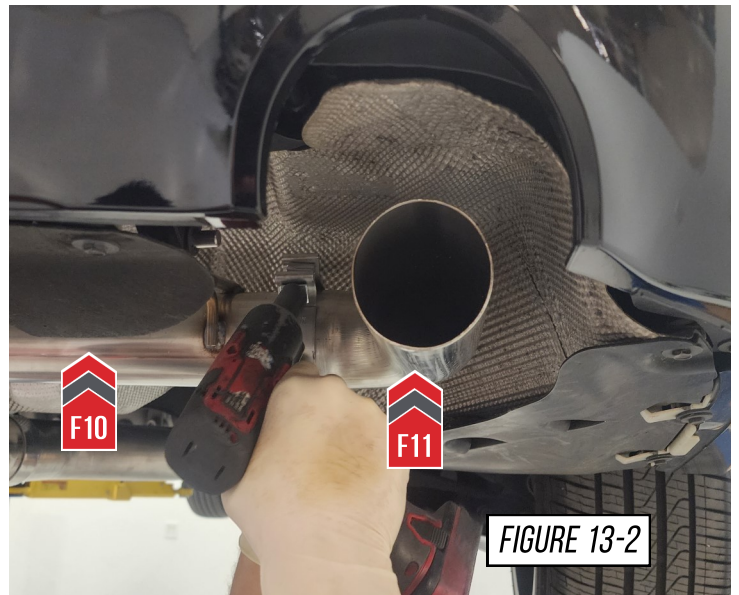
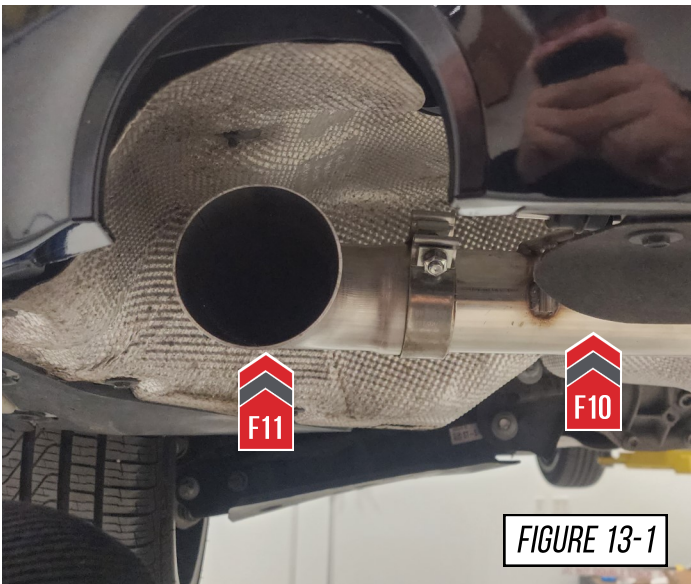

STEP 14

To install the exhaust tips with integrated clamps, first, attach the exhaust tip in the proper orientation onto the exhaust outlet tube.

Insert one of the carriage bolts from the hardware kit (**3910-41010**) through the tab on the exhaust tip and thread on one of the corresponding nuts.

Using anti-seize on the bolt threads will help installation and prevent breakage of hardware.

 If exhaust system only has 2 exhaust tips while the integrated clamp kit has enough hardware for our 4 tip exhaust systems. You will have 2 sets of hardware left over that will not be used.

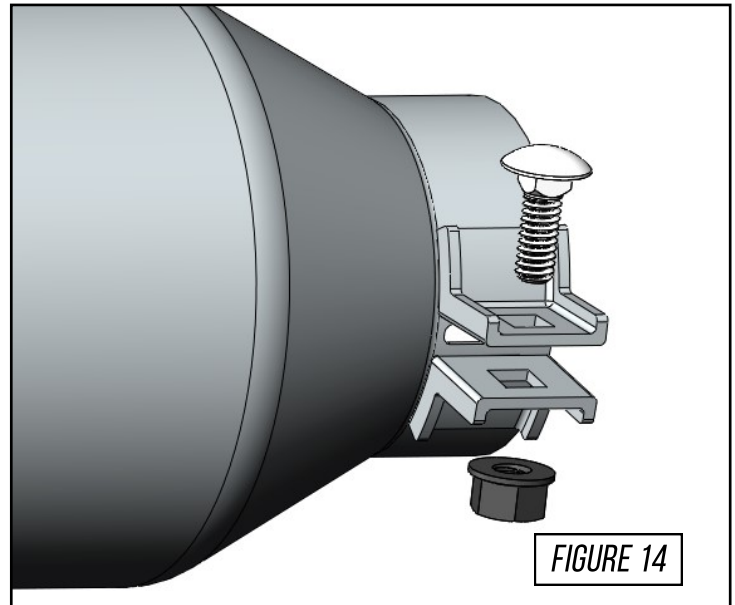

STEP 15

Install your 2 AWE exhaust tips onto the tip outlets with the provided hardware, as shown in **Figure 15-1**, and **Figure 15-2**.

Note: When installing tips be careful not to scratch the rear valance

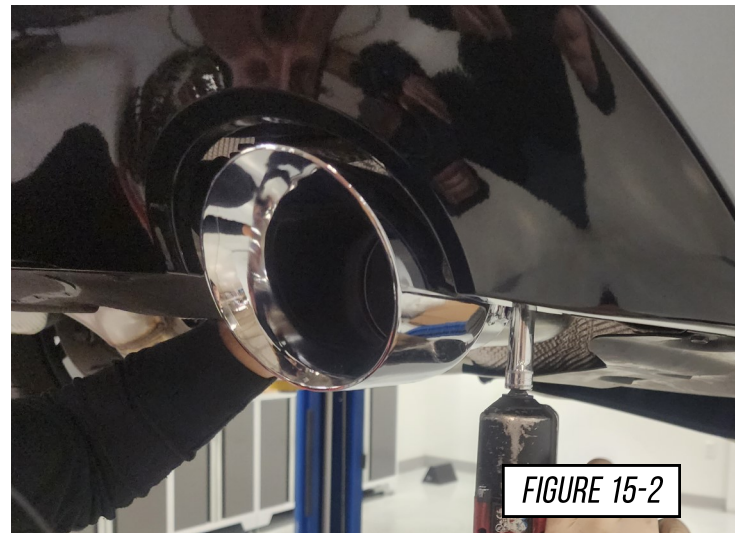
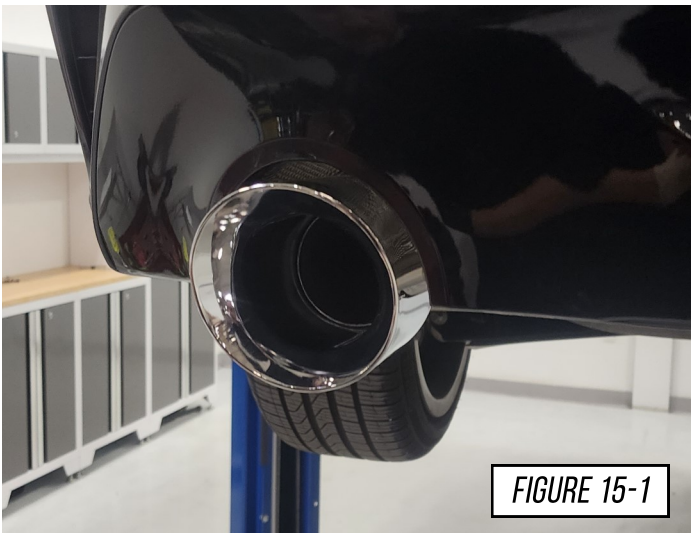

STEP 16

Install your AWE lock collars on the AWE rear section hanger bars. The driver side lock collar (A) is shown in **Figure 16-1**. The passenger side lock collar (B) is shown in **Figure 16-2**.

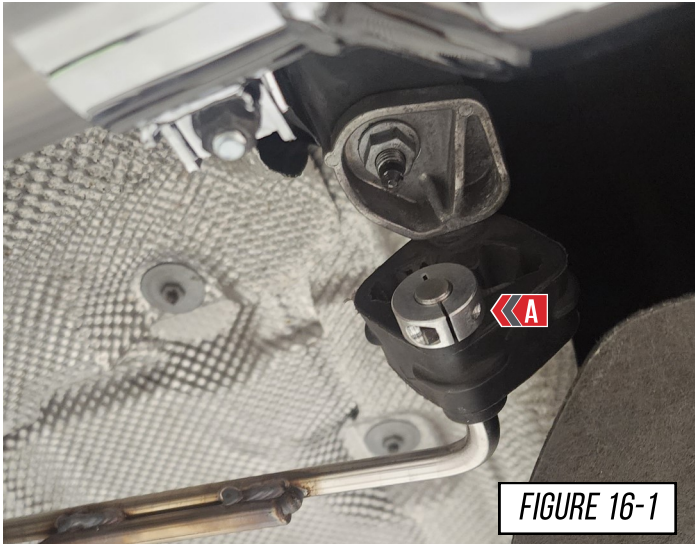

FIGURE 16-1

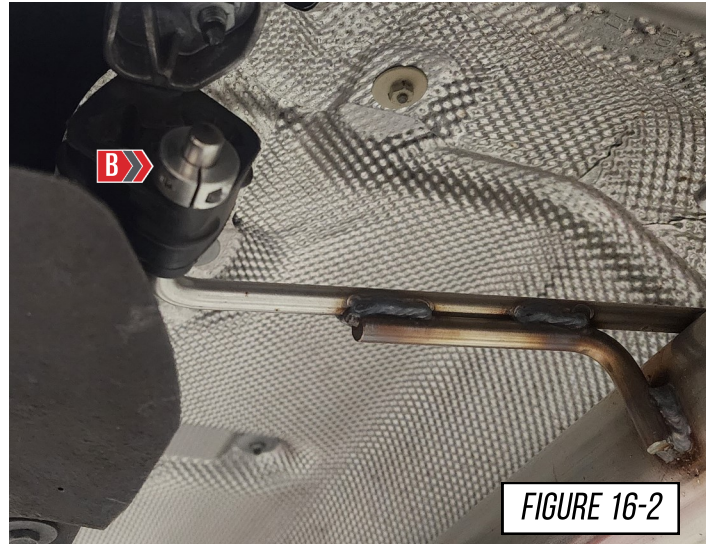

FIGURE 16-2

STEP 17

Make your final adjustments to the tips to ensure they are in a position you like. Once the desired positioning is achieved work from the front of the car to the back, tightening all the clamps fully and ensuring there is proper clearance of the chassis, and braces.

It is now recommended to drive the car to allow the exhaust to heat cycle after all clamps and tips are fully tightened.



At this point the exhaust will be **very hot**, allow to cool before work continues.

Check the tips for correct alignment, adjust as needed.



Don't forget to see the next page for any troubleshooting needs!



FIGURE 17

ENJOY!



TROUBLESHOOTING

Issue	Solution
Exhaust is not fitting correctly	Most fitment issues are due to improperly adjusted exhaust. This includes tip fitments and rattling due to chassis contact. Check out our fitment guide for more installation tips.
Incorrect or missing parts	Double check the parts list for your system and compare them with what you received. Fill out our contact form, found below and let us know what parts you need.

CARE

Once installed properly, your AWE exhaust will provide years of trouble-free performance.

The exhaust volume and sound will settle with usage; 800-1000 miles is required to break-in new exhaust systems.

Also, please note that the rear **180Technology**[®] resonator has a small drain hole to allow condensation to escape. Water drops from this area are normal.

Periodic cleaning of exhaust tips is necessary to maintain proper finish, especially in areas prone to road salt and caustic deicing solutions. Use a mild soap and water solution or car wax to clean the finish. Avoid using abrasive polishes, as they can scratch the finish.

Any questions or comments,
please do not hesitate to contact us:

AWE
[CONTACT FORM](#)

WARRANTY

Up-to-date warranty information is found [HERE](#).