



PERFORMANCE EXHAUST

IMPORTANT WARRANTY & INSTALLATION INSTRUCTIONS ATTACHED

*Please Forward All Attached Information to Consumer. Warranty
Not Valid Unless Returned to dB Performance Exhaust*

We ask that you take a few moments to
Complete our warranty registration form.

To Activate Your 10 Year LIMITED WARRANTY, Go To:
dBexhaust.com/warranty



MADE IN THE USA



For Full-Color Installation Instructions, Please Visit:
dBexhaust.com & Search Part #

Please be sure to review the enclosed instructions prior to beginning the installation process. If you have any questions about the enclosed parts, instructions or encounter a problem during installation, CALL dB Performance Exhaust TECHNICAL ASSISTANCE AT 800.486.0999

dB Performance Exhaust / 140 Blaze Industrial Pkwy / Berea, OH 44017



dB Performance Exhaust System Installation
Axle-Back Exhaust System
2007-2016 Jeep Wrangler
Single Rear Exit – Part Number 24411
Dual Rear Exit – Part Number 24412

Please take time to read and understand these installation instructions.

We recommend that the installation of this system be performed by a qualified service center or professional muffler installer who has the necessary equipment, tools and experienced personnel. However, if you decide to perform this install, the use of a hoist and an additional person will be required.

CAUTION: Never work on a hot exhaust system. Allow time for the vehicle to cool. Always wear eye protection when working under a vehicle.

Recommended Tools:

• Safety Glasses • 15mm Wrench or Deep Socket • Torque wrench • Soap & Water Solution

Please confirm that all parts are present before beginning the factory exhaust system removal and dB Performance Exhaust system installation.

Part # 24411 Bill of Materials:

- 1- 17CH2150 (dB Muffler Assembly)
- 2- 17CH3018 (dB Performance Tip)
- 3- 17CH4205 (Tip Tube)
- 4- 17CH7057 (Hardware Kit)

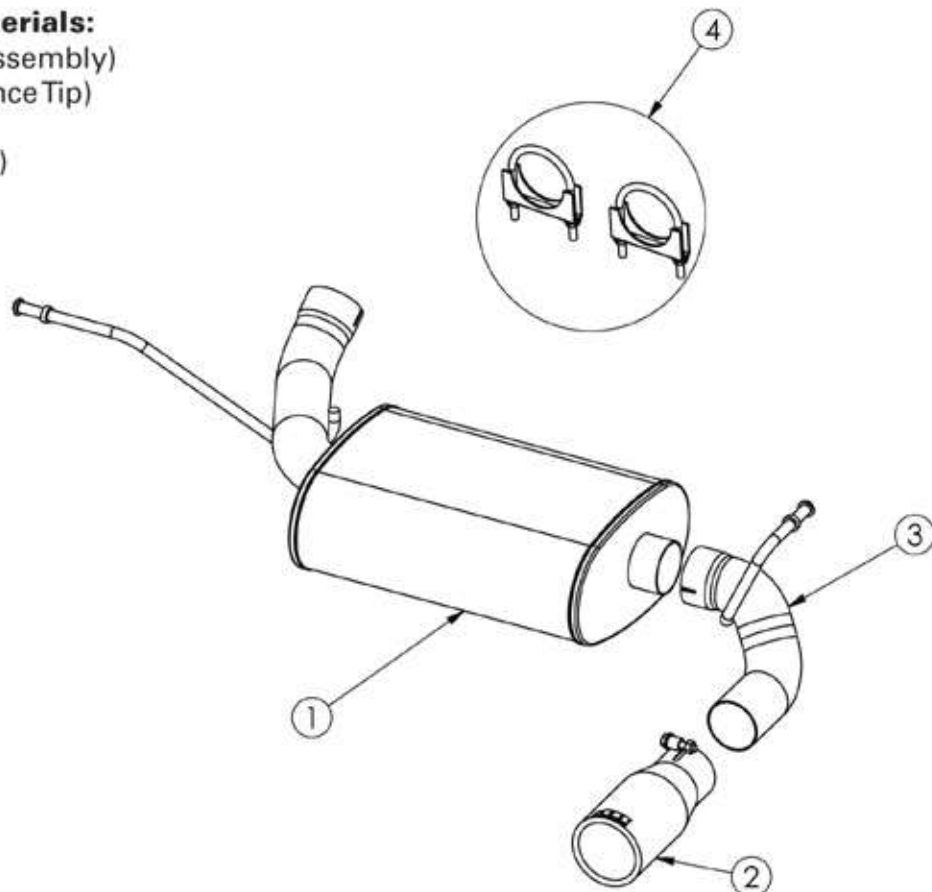

Part # 24412 Bill of Materials:

- 1- 17CH2151 (dB Muffler Assembly)
- 2- 17CH3018 (dB Performance Tip)
- 3- 17CH4210 (Tip Tube)
- 4- 17CH7057 (Hardware Kit)

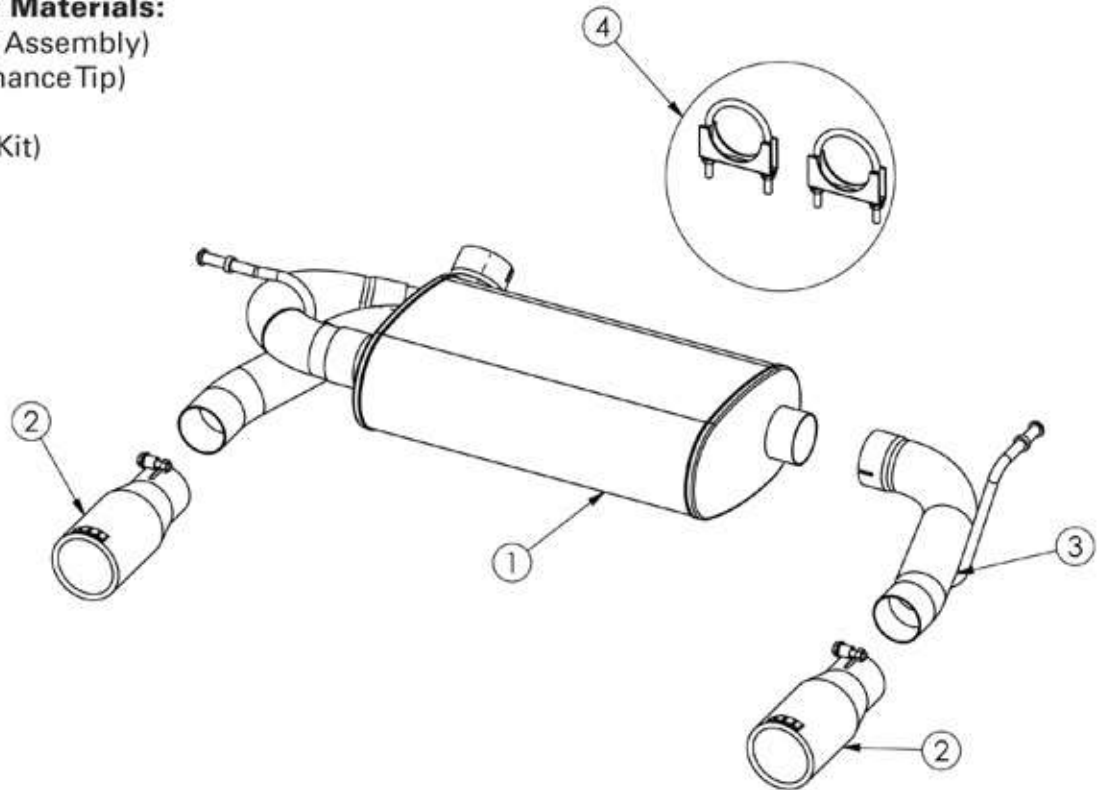

Removal of Stock System:

- 1) Using a 15mm socket, loosen the factory clamp at the inlet of the muffler.
- 2) Using grommet pullers or similar device, remove passenger side muffler hanger from rubber grommet. (See Fig A)

NOTE: Using soapy water solution on the grommet hole will make the job easier.

- 3) Using grommet pullers or similar device, remove driver side muffler hanger from rubber grommet. Carefully slide the muffler from clamped location. This completes the removal of the stock system. (See Fig B & C)

NOTE: Using soapy water solution on the grommet hole will make the job easier.



FIG. A



FIG. B



FIG. C

Installation of dB Performance Exhaust System:

NOTE: The supplied double edge clamps in this system will crush and permanently deform the exhaust piping as they are tightened. DO NOT tighten these clamps any more than is necessary to lightly hold the exhaust components in place, until the very end of this installation process. It will be difficult or impossible to make any positional or rotational adjustments to the exhaust system after these clamps have been tightened down.

VERY IMPORTANT: Align all clamps so that the open edge of the clamp bracket is parallel and aligned with the notch in the pipe, and the outside edge of the clamp bracket is approximately 1/8" from the end of the pipe expansion. (See Fig. 1) Failure to properly position or orient the clamps could result in a weak clamping load, or even a potential leak at the clamp joints.

IMPORTANT: Make sure that the small drain holes in the muffler are facing down when the muffler is installed. (See Fig. 2)

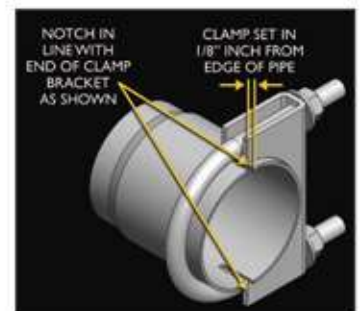

FIG. 1



FIG. 2

1) Locate the dB muffler and slide the expanded inlet end onto the factory pipe. Next, slide the hanger through the rubber grommet. Slide a 2.5" clamp over the expanded end of the muffler. Pre-tighten the clamp at this time. (See Fig D & E)

NOTE: Using soapy water solution on the grommet hole will make the job easier.

2) Locate passenger side tip tube and slide the hanger through the rubber grommet. Next, slide the expanded end over the outlet end of the muffler. Slide a 2.5" clamp over the expanded end of the tip tube. Pre-tighten the clamp at this time. (See Fig F)

3) Locate the tip and slide the tip onto the exit end of the muffler. Align the tip so that there is about a one-half to one inch gap between the top of the tip and the bottom of the body panel with logo facing up. Pre-tighten the clamp at this time. (See Fig G)

> For part number 24412 (dual exhaust) only, repeat step 3 for driver side.

- 4) Starting from the muffler inlet and working back, tighten all the clamps to 35 ft-lbs. Tip clamp torque setting: 16-20 ft-lbs.
- 5) It is **strongly recommended** that all clamps be checked and tightened after road testing the vehicle once the system has cooled.

NOTE: During cold weather start-ups, you may experience an exhaust sound that is deeper and louder in tone than usual. This is temporary and will diminish to normal levels once your engine has reached its normal operating temperature. **NOTE:** Immediately following the installation of your exhaust system, you may experience a trace of smoke after initial start-up. **DO NOT** be alarmed. The smoke is caused by the burning of a small amount of forming oil residue used in the manufacturing process.



FIG. D



FIG. E



FIG. F



FIG. G