



## IMPORTANT WARRANTY & INSTALLATION INSTRUCTIONS ATTACHED

*Please Forward All Attached Information to Consumer  
Warranty Not Valid Unless Returned to CORSA Exhaust*

We ask that you take a few moments to complete our warranty registration form:

TO ACTIVATE YOUR LIMITED LIFETIME WARRANTY GO TO:

**[CORSAPERFORMANCE.COM/WARRANTY](http://CORSAPERFORMANCE.COM/WARRANTY)**



For Full-Color Installation Instructions, Please Visit:

**[CORSAPERFORMANCE.COM](http://CORSAPERFORMANCE.COM) and Search by Part Number**

Please be sure to review the enclosed instructions prior to beginning the installation process. If you have any questions about the enclosed parts, instructions or encounter a problem during Installation: **CALL CORSA PERFORMANCE TECHNICAL ASSISTANCE AT 800.486.0999**



**Please take time to read and understand these installation instructions.**

CORSA recommends that installation of this system be performed by a qualified service center or professional muffler installer who has the necessary equipment, tools and experienced personnel. However, if you decide to perform this install, the use of a hoist and an additional person will be required.

**CAUTION:** Never work on a hot exhaust system. Allow time for the vehicle to cool. Always wear eye protection when working under a vehicle.

**Please confirm that all parts are present before beginning the factory exhaust system removal and CORSA exhaust system installation.**

## Recommended Tools:

- Safety Glasses
- 15mm Socket & Ratchet
- 1/2" Wrench
- Saw or Chain-Style Pipe Cutter
- Torque Wrench
- File or Sanding Device for Deburring
- Grommet Pullers
- Soap & Water Solution

## Bill of Materials:

- 1 - Driver Muffler Assembly  
SPORT (15CV2049) / TOURING (15CV2051)
- 2- Passenger Muffler Assembly  
SPORT (15CV2050) / TOURING (15CV2052)
- 3- Hardware Kit (15CV7020)

14942-Sport

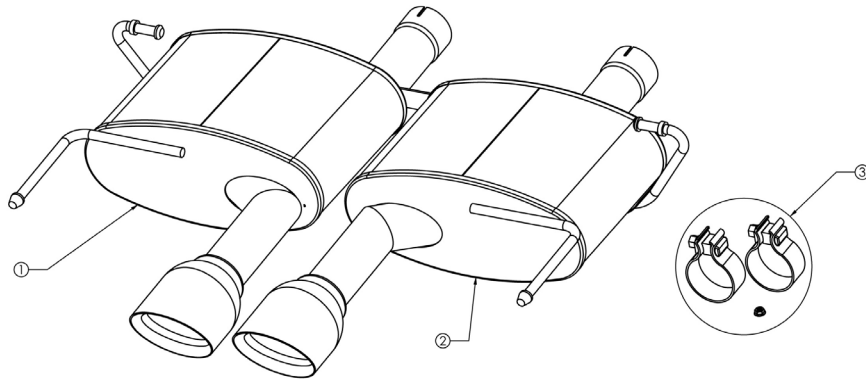

14943-Touring

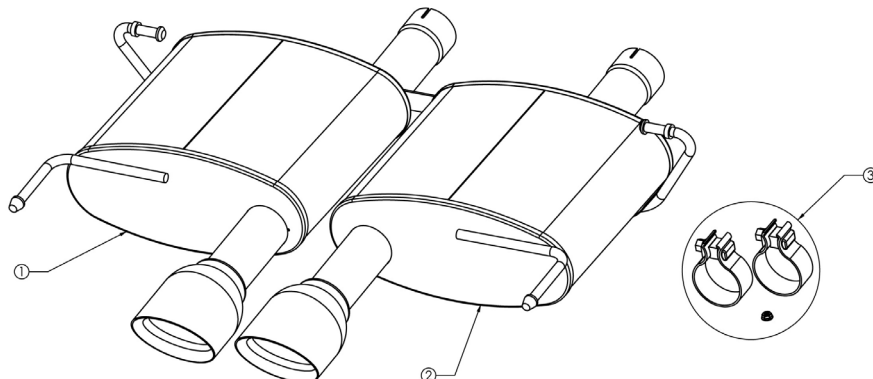

## Removal of Stock System:

1. Mark the stock axle pipes at the frame notch near the rear axles on both sides. (See Fig. A & B)
2. From the mark in step 1, measure  $\frac{3}{4}$ " towards the rear of the vehicle and this new mark will be your cut line. Using a saw or chain style pipe cutter, cut both axle pipes at the mark. (See Fig. C & D)
3. Using a grommet puller or similar device, remove hangers from grommets at rear of stock muffler; located inside bumper cover. There are two per side. (See Fig. E)

**NOTE:** The use of a soapy water solution may aid in the removal and later installation of the hangers in the rubber isolators.

4. Remove hangers from grommets at inlet of stock muffler; located behind sway bar bracket. There is one per side. (See Fig. F)
5. Removal is complete. Installation of your CORSA Performance exhaust system can now begin.



Fig. A

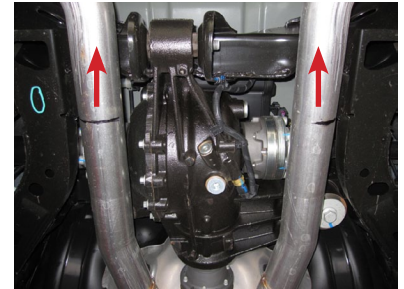

Fig. B

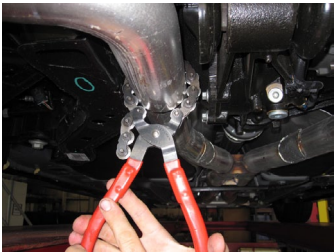

Fig. C



Fig. D

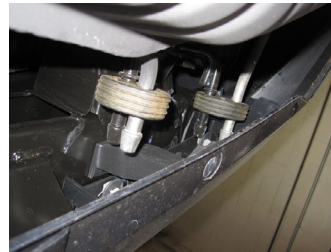

Fig. E



Fig. F

## Installation of CORSA Exhaust System:

**NOTE:** Apply the anti-seize lubricant (supplied) to the threads **ONLY** of all the clamps and flange bolts. Failure to follow this procedure can cause nuts to seize on clamps and potentially destroy threads. After applying anti-seize lubricant, be sure to thoroughly clean hands as lubricant will tarnish stainless steel.

**NOTE:** Align all clamps so that the center of the clamp bolt is 90 degrees from the notch in the pipe (See Fig. G, CLAMP, to the right.)

All clamps should be tightened using a properly calibrated Torque Wrench. Using an air impact gun will damage the clamp and reduce its ability to effectively seal the joint. It may also cause the joint to separate thereby causing damage to your exhaust system and your vehicle.

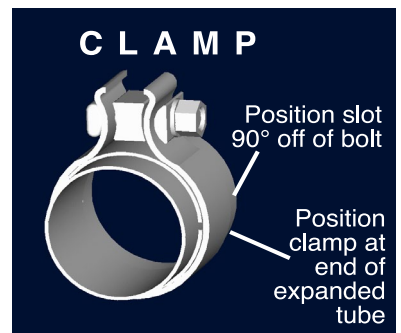

Fig. G

Continue to next page for step 1 of the installation process

1. Starting with passenger side, insert rear hanger into inside rear grommet (outer rear grommet is no longer used on either side.) **(See Fig. H)**
2. Place supplied clamp over inlet of muffler in proper position and slide expanded inlet over stock axle pipe. **(See Fig. I)**
3. Insert front hanger into grommet. **(See Fig. J)**
4. Repeat steps 1-3 on driver side.

**Note:** Stud on front of driver muffler must be inserted into slot of passenger side bracket before sliding the expanded end over the stock axle pipe.

5. Thread supplied nut onto stud to tie mufflers together at inlet, do not tighten yet. **(See Fig. K)**
6. Visually inspect the exhaust system position, tip alignment, clamp orientation, and exhaust pipe clearance. Make any changes by adjusting the depth and rotation of front clamps.
7. Once in desired position, tighten the nuts on the clamps with 15mm socket. Torque nuts to **45 ft-lbs (65 N-m)**. **(See Fig. L)** The nut in step 5 should be tightened with 1/2" wrench to **18 ft-lbs (24 N-m)**.
8. It is **STRONGLY SUGGESTED** that all clamps be checked and re-tightened (if necessary) to the recommended torque after initial road testing of the vehicle, as thermal cycling has occurred on the system. Please wait until system has fully cooled to conduct this process.

**NOTE:** During cold weather start-ups, you may experience an exhaust sound that is deeper and louder in tone than usual. This is temporary and will diminish to normal levels once your engine has reached its normal operating temperature.

**NOTE:** Immediately following the installation of your exhaust system, you may experience a trace of smoke after initial start-up. **DO NOT** be alarmed. The smoke is caused by the burning of a small amount of forming oil residue used in the manufacturing process.



**Fig. H**



**Fig. I**

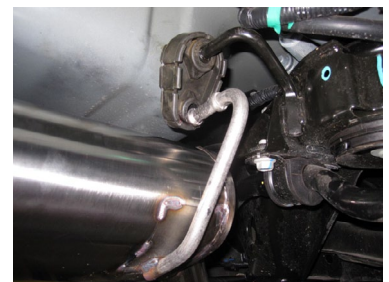

**Fig. J**



**Fig. K**

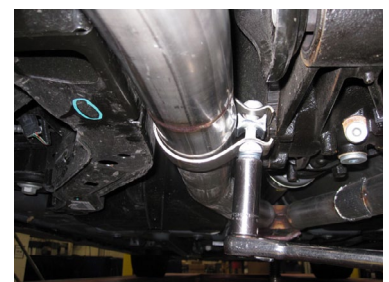

**Fig. L**