



IMPORTANT WARRANTY & INSTALLATION INSTRUCTIONS ATTACHED

*Please Forward All Attached Information to Consumer
Warranty Not Valid Unless Returned to CORSA Exhaust*

We ask that you take a few moments to complete our warranty registration form:

TO ACTIVATE YOUR LIMITED LIFETIME WARRANTY GO TO:

CORSAPERFORMANCE.COM/WARRANTY



For Full-Color Installation Instructions, Please Visit:

CORSAPERFORMANCE.COM and Search by Part Number

Please be sure to review the enclosed instructions prior to beginning the installation process.
If you have any questions about the enclosed parts, instructions or encounter a problem during
Installation: **CALL CORSA PERFORMANCE TECHNICAL ASSISTANCE AT
800.486.0999**

Please take time to read and understand these installation instructions.

CORSA recommends that installation of this system be performed by a qualified service center or professional muffler installer who has the necessary equipment, tools and experienced personnel. However, if you decide to perform this install, the use of a 2-post hoist and an additional person will be required.

CAUTION: Never work on a hot exhaust system. Allow time for the vehicle to cool. Always wear eye protection when working under a vehicle.

Please confirm that all parts are present before beginning the factory exhaust system removal and CORSA exhaust system installation.

Bill of Materials:

14256 – Complete System ~Sport

- ① **14686**– Sport muffler kit (BOX 1)
16SR2000 – Sport muffler
- ② **14623**– Trailblazer SS pipe kit (BOX 2)
16TB4002 – Intermediate Pipe Assembly
16TB4003 – Tailpipe Assembly
16TB4009 – Tip Tube
20FF7026 – Hardware Kit
16CF7001- 3" Torca Clamp (QTY:3)
14981 - Anti-Seize
INS5075 – Instruction Sheet

14257 – Complete System ~Touring

- ① **14687**– Touring muffler kit (BOX 1)
16SR2001 – Touring muffler
- ② **14623** – Trailblazer SS pipe kit (BOX 2)
16TB4002 – Intermediate Pipe Assembly
16TB4003 – Tailpipe Assembly
16TB4009 – Tip Tube
20FF7026 – Hardware Kit
16CF7001- 3" Torca Clamp (QTY:3)
14981 - Anti-Seize
INS5075 – Instruction Sheet

Recommended Tools:

- Safety glasses
- Ratchet
- 15mm wrench or deep socket
- 13mm deep socket
- Torque wrench
- Chain style pipe cutter or hacksaw
- Spray bottle of soapy water (optional)
- 1/2" thick block

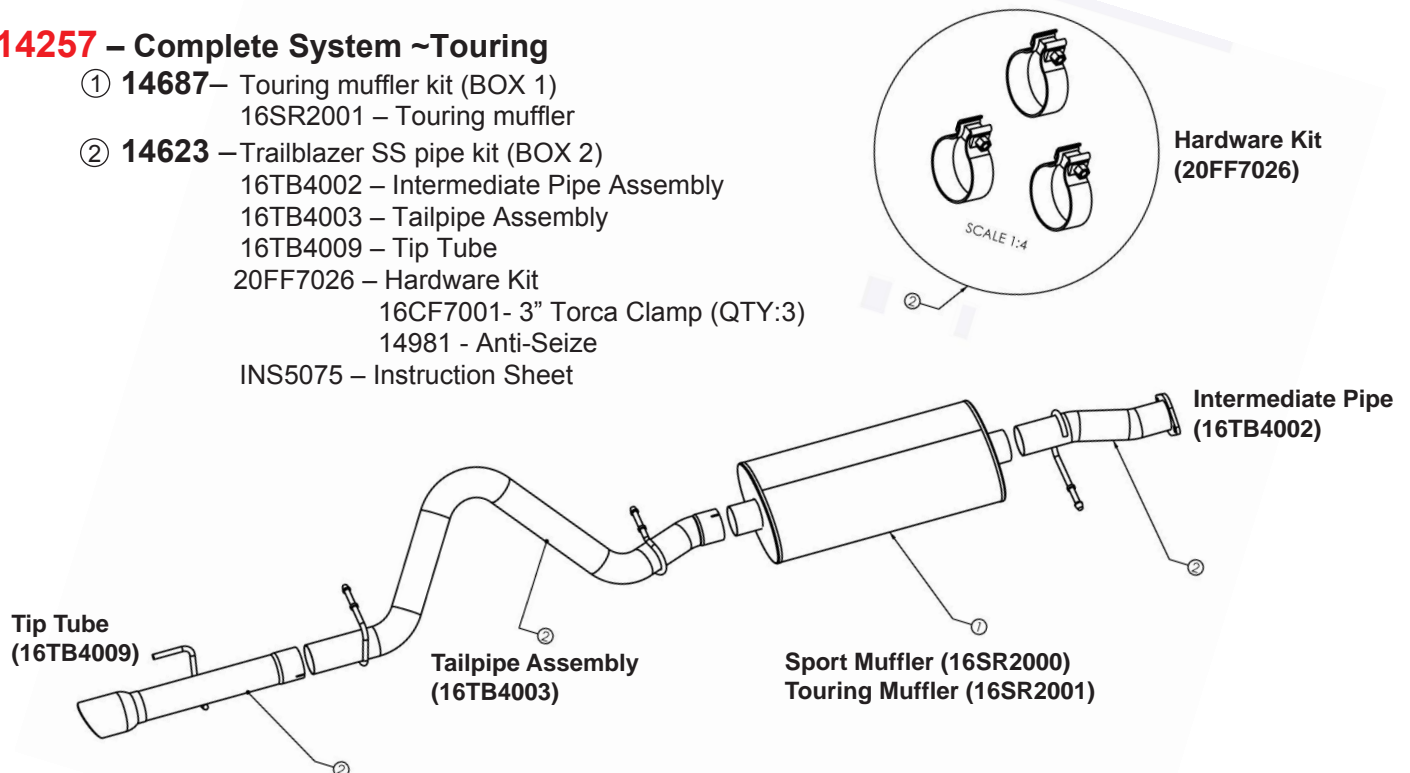

Removal of Stock System:

1. Mark stock tailpipe 4.25" from the rear face of the large center muffler (see Fig A), and cut on mark with a chain style pipe cutter or hacksaw (see Fig B).
2. Next, remove the hanger from the rubber grommet closest to the cut (see Fig C), and then the next hanger on the tailpipe moving towards the rear of the vehicle (see Fig D). **NOTE: The optional step of spraying grommets with soapy water may aid the process of removing and installing hangers.**
3. The rearmost hanger on the tailpipe is removed from its grommet by sliding the tailpipe towards the front of the vehicle (see Fig E). **NOTE: If using a "drive on lift", you can gain more clearance over the axle by lifting the rear of the vehicle approximately 6" using the hitch as the lifting point (see Fig F). This rear section remains lifted for the complete installation process, so be sure to properly secure the vehicle before working beneath it.**
NOTE: Do NOT lift rear of vehicle if using a 2-post lift, as this could make the vehicle unstable and create unsafe working conditions.
4. Once free from the third hanger, the tailpipe can be removed by pulling towards the rear of the vehicle and twisting the pipe when necessary to avoid getting caught on heat shields and hangers (see Fig G).
5. Moving to the front half of the stock system, remove the 15mm nuts at the flange after the flex coupler (see Fig H) and remove the final hanger from the rubber grommet (see Fig I).
6. The rest of the stock system can now be removed by pulling it towards the rear of the vehicle, over the cross brace (see Fig J).



FIG. A

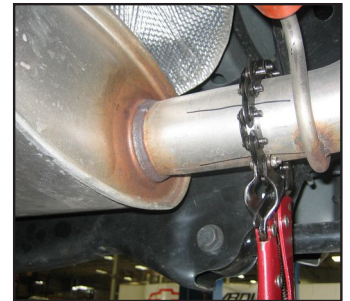

FIG. B



FIG. C



FIG. D

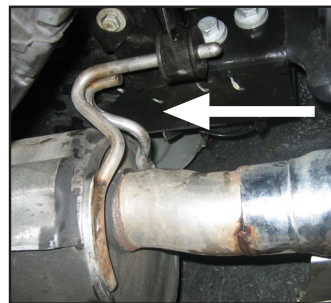

FIG. E

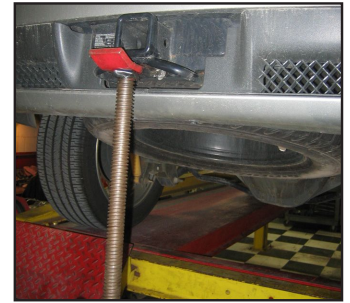

FIG. F



FIG. G

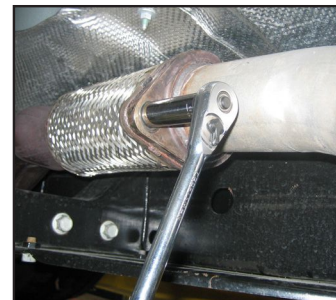

FIG. H



FIG. I



FIG. J

Installation of CORSA Exhaust System:

NOTE: Apply the anti-seize lubricant (supplied) to the threads **ONLY** of all the clamps and flange bolts. Failure to follow this procedure can cause nuts to seize on clamps and potentially destroy threads. After applying anti-seize lubricant, be sure to thoroughly clean hands as lubricant will tarnish stainless steel.

All clamps should be tightened using a properly calibrated Torque Wrench. Using an air impact gun will damage the clamp and reduce its ability to effectively seal the joint. It may also cause the joint to separate thereby causing damage to your exhaust system and your vehicle.

1. Remove all exhaust system components from the shipping cartons, including the (2) 3" clamps.
2. Locate supplied Intermediate Pipe (see Fig K) and slide the flange over the factory studs and insert the hanger into the rubber grommet (see Fig L). **NOTE: The optional step of spraying grommets with soapy water may aid the process of removing and installing hangers.**
3. After the hanger is in place, the flange nuts should be tightened to 33 ft-lb. (see Fig M).
4. Locate supplied Muffler (see Fig N) and slide supplied clamp over the expanded end (see Fig O). Make sure that both the nut of the clamp and the weep hole drilled in the bottom of the muffler are facing down when installed on the vehicle (see Fig P).
5. Locate supplied Tailpipe and Tip Tube (see Fig Q), and begin installing it from the rear of the vehicle, over the rear suspension components, with the large "over axle" bend pointing down and twisting the pipe counter-clockwise while advancing (see Fig R).



FIG. K



FIG. L

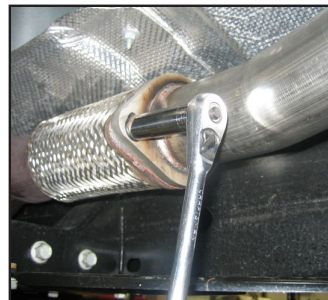

FIG. M



FIG. N

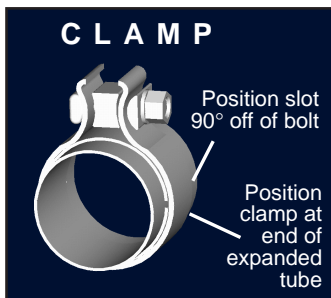

FIG. O

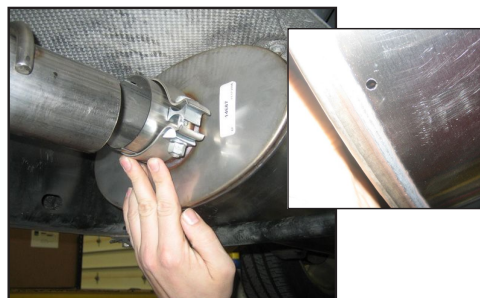

FIG. P

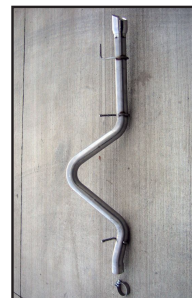

FIG. Q



FIG. R

6. After the tailpipe is over the axle, insert the rear most hanger into the grommet just aft of the rear bumper (see Fig S). **NOTE: The optional step of spraying grommets with soapy water may aid the process of removing and installing hangers.**
7. Next, place a clamp over the expanded end of the tailpipe with the nut facing down and insert the hanger nearest the clamp into the rubber grommet (see Fig T). Then insert the last hanger into the rubber grommet (see Fig U).
8. Before tightening any clamps, place a 1/2" spacer block or hold the muffler 1/2" above the cross brace to prevent contact (see Fig V).
9. Only snug tighten the inlet clamp on the muffler, and then the outlet clamp before checking tip alignment (see Fig W).



FIG. S

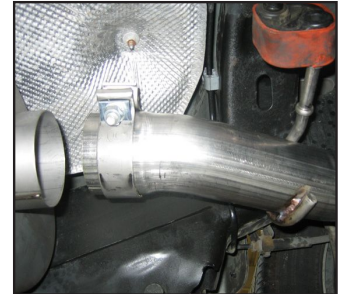

FIG. T



FIG. U



FIG. V



FIG. W

**Technical Assistance:
Call
800.486.0999.**

Tip Alignment:

- Most adjustments to center the tip in the bumper cutout can be made by twisting the tailpipe at the outlet of the muffler before final tightening.
 - Greater horizontal adjustments can be made on the bracket of the rearmost hanger by loosening the (2) 13mm bolts and sliding the bracket left to right (see Fig X). Make sure to retighten to 18 ft-lb.
10. After the tip is in place, the (2) clamps should be tightened to 45 ft-lb and the block spacing the muffler from the cross brace should be removed. The muffler will naturally settle, but measure to verify that 1/4" of space remains between the brace and muffler (see Fig Y). If the spacing is less than 1/4" the clamps need to be retightened while the muffler is pushed up.

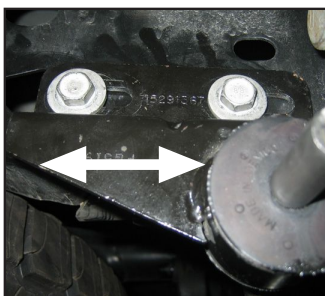

FIG. X



FIG. Y

It is strongly suggested that all clamps be checked and tightened after road testing the vehicle once the system has cooled.

NOTE: During cold weather start-ups, you may experience an exhaust sound that is deeper and louder in tone than usual. This is temporary and will diminish to normal levels once your engine has reached its normal operating temperature.

NOTE: Immediately following the installation of your CORSA exhaust system, you may experience a trace of smoke after initial start-up. **DO NOT** be alarmed. The smoke is caused by the burning of a small amount of forming oil residue used in the manufacturing process.