



Kits 78662/78664

Volkswagen MKVII

Rear Application

***Independent Suspension
(with and without shocks)***



INSTALLATION GUIDE

For maximum effectiveness and safety, please read these instructions completely before proceeding with installation.

Failure to read these instructions can result in an incorrect installation.

TABLE OF CONTENTS

Introduction	2
Notation Explanation	2
Important Safety Notices	2
Installation Diagram	3
Hardware List	3
Installing the Air Suspension	4
Preparing the Vehicle	4
Removal of Stock Suspension	4
Installing the Kit Components	6
Routing the Air Lines	9
Finished Installation	9
Tips for Installing the Air Lines	10
Cutting Air Lines	10
Push-to-Connect (PTC) Fittings	10
Checking for Leaks	10
Fixing Leaks	10
Before Operating	11
Setting the Ride Height	11
Torque Specifications	11
Suggested Driving Air Pressure and Maximum Air Pressure	11
Check for Binding	12
Damping Adjustment	12
Aligning the Vehicle	12
Installation Checklist	13
Post-installation Checklist	13
Use, Maintenance and Servicing	14
Tuning the Air Pressure	14
Troubleshooting Guide	15
Limited Warranty and Return Policy	17
Replacement Part Information	17
Contact Information	17

Introduction

Air Lift Performance thanks you for purchasing the most complete, fully engineered high-performance air suspension made for the Volkswagen MKVII. Read these installation instructions to correctly and safely set up the vehicle for a #lifeonair.

Air Lift assumes that the installer has the mechanical knowledge and ability to work on vehicle suspension systems and has basic tools necessary to complete the project. Special tools needed to complete the installation are noted on the Installation Diagram page.

Air Lift reserves the right to make changes and improvements to its products and publications at any time. For the latest version of this manual, contact Air Lift Performance at **(800) 248-0892** or visit **www.airliftperformance.com**.

An Air Lift Performance air management system is highly recommended for this product. Learn more at **air-lift.co/productlines**.

NOTATION EXPLANATION

Hazard notations appear in various locations in this publication. Information which is highlighted by one of these notations must be observed to help minimize risk of personal injury or possible improper installation which may render the vehicle unsafe. Notes are used to help emphasize areas of procedural importance and provide helpful suggestions. The following definitions explain the use of these notations as they appear throughout this guide.



DANGER

INDICATES IMMEDIATE HAZARDS WHICH WILL RESULT IN SEVERE PERSONAL INJURY OR DEATH.



WARNING

INDICATES HAZARDS OR UNSAFE PRACTICES WHICH COULD RESULT IN SEVERE PERSONAL INJURY OR DEATH.



CAUTION

INDICATES HAZARDS OR UNSAFE PRACTICES WHICH COULD RESULT IN DAMAGE TO THE MACHINE OR MINOR PERSONAL INJURY.

NOTE

Indicates a procedure, practice or hint which is important to highlight.

Important Safety Notices



WARNING

DO NOT INFLATE AIR SPRINGS WHILE OFF OF THE VEHICLE. DAMAGE TO ASSEMBLY MAY RESULT AND VOID WARRANTY.



CAUTION

DO NOT WELD TO OR MODIFY PERFORMANCE STRUTS/SOCKS IN ANY WAY. DAMAGE TO UNIT MAY OCCUR AND WILL VOID WARRANTY.

Installation Diagram

NOTE:
Kit 78662 uses
factory shocks.

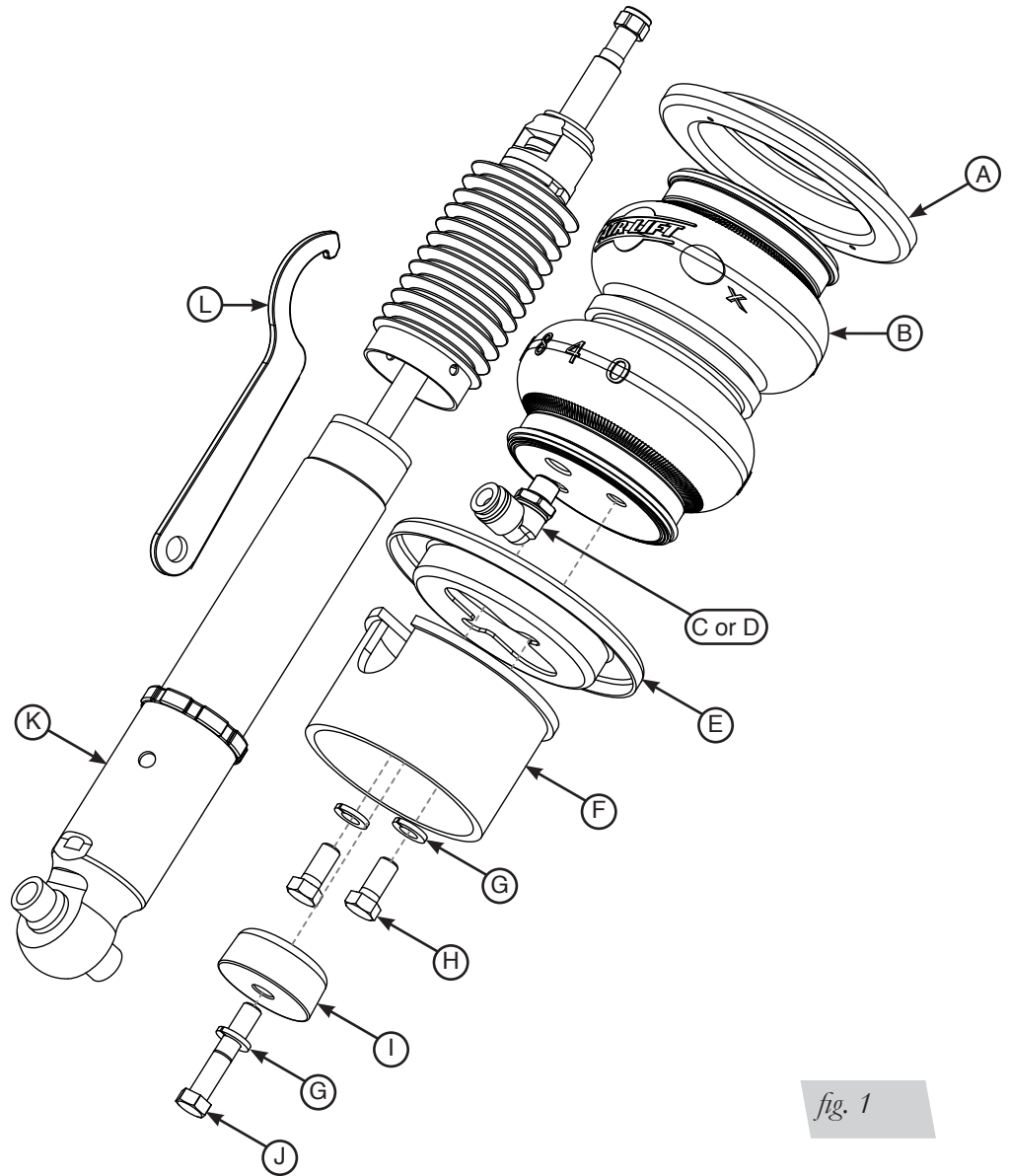

fig. 1

HARDWARE LIST

Item	Part #	Description	Qty	Item	Part #	Description	Qty
A	11805	Upper roll plate.....	2	G	18427	3/8" Lock washer.....	6
B	58547	Air spring	2	H	17203	3/8"-24 x 7/8" Hex bolt	4
C	21779	1/4" MNPT x 1/4" PTC elbow, DOT	2	I	13993	Centering spacer.....	2
D	21851	1/4" FNPT x 3/8" PTC, elbow, DOT	2	J	17511	3/8"-24 x 2" Hex cap screw.....	2
E	11803	Lower roll plate.....	2	K	26779	MKVII rear shock.....	2
F	03026	Spring seat.....	2	L	11289	Spanner wrench.....	1



Missing or damaged parts? Call Air Lift customer service at (800) 248-0892 for a replacement part.

Installing the Air Suspension

NOTE

See important safety notices on page 2.

PREPARING THE VEHICLE

1. Elevate and support the vehicle with a hoist or jack stands. Remove the rear wheel (Figs. 2 & 3).

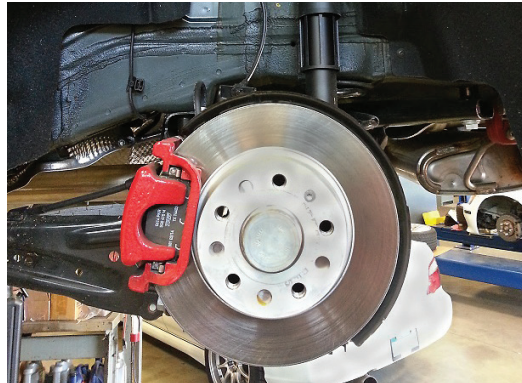

fig. 2



fig. 3

REMOVAL OF STOCK SUSPENSION

1. If the vehicle has the headlamp alignment system, unclip the armature from the bracket attached to the control arm. If it doesn't have this feature, skip to step 2. (Fig. 4).
2. Unbolt the stabilizer end link from the lower control arm. Disconnect the end link from the opposite side control arm (Figs. 5 & 6).

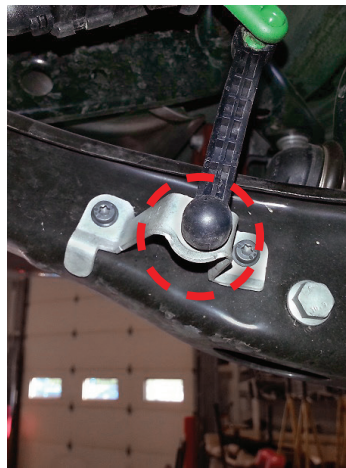

fig. 4



fig. 5



fig. 6

3. Remove the nut from the lower shock eye mount (Fig. 7).



fig. 7

4. Remove the outer hub-to-control arm bolt and nut (Fig. 8).

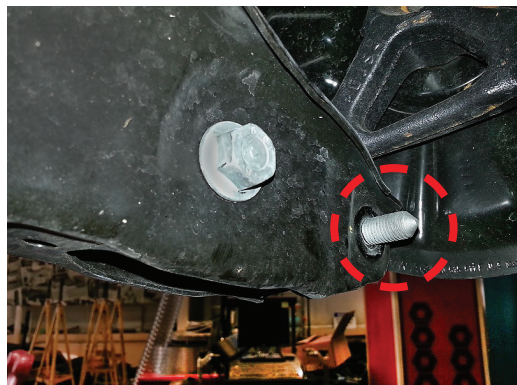

fig. 8

CAUTION

THE COIL SPRING IS UNDER PRESSURE. USE A JACK TO SUPPORT THE LOWER CONTROL ARM BEFORE REMOVING THE HUB AND SHOCK BOLTS.

5. Remove the shock and hub bolts (Fig. 9) and slowly lower the arm until the coil spring is free to remove (Figs. 10 & 11).



fig. 9



fig. 10



fig. 11

6. If installing kit 78662 without rear shocks, move on to Step 3 of “Installing the Kit Components.” Remove the fender liner and unbolt the shock upper mount (Fig. 12). Remove the assembly from the vehicle (Fig. 13).

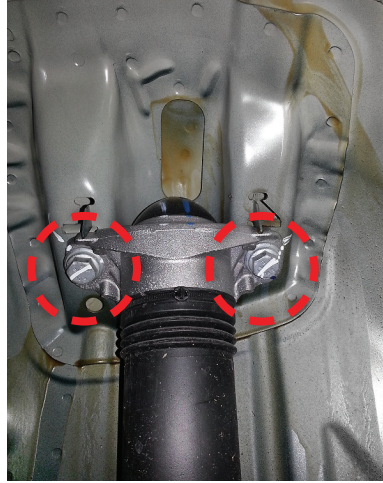

fig. 12



fig. 13

INSTALLING THE KIT COMPONENTS

1. Disassemble the stock rear shock from the upper mount. Remove the lower dust cover and jounce bumper from the mount (Fig. 14). Install the upper mount to the Air Lift Performance shock with the adjuster lettering facing outboard (Figs. 15 & 16). Torque rod nut to 27Nm (20 lb.-ft.).

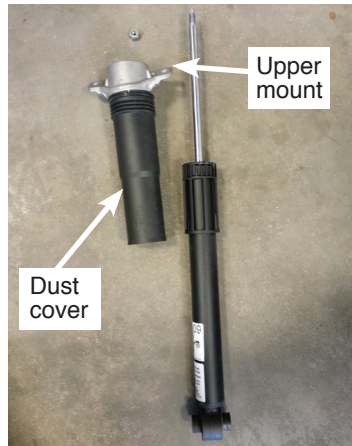

fig. 14

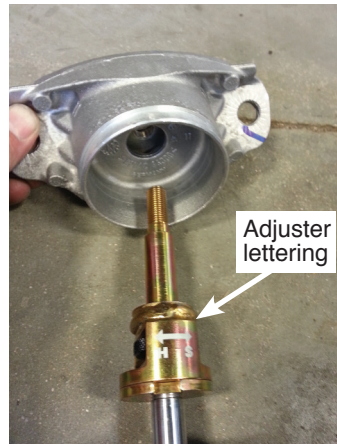

fig. 15



fig. 16

2. Apply the plastic cap to the top of the mount and reattach it to the vehicle chassis. Torque upper chassis bolts to 50Nm + 90 degrees (37 lb.-ft. + 90 degrees) (Fig. 17).

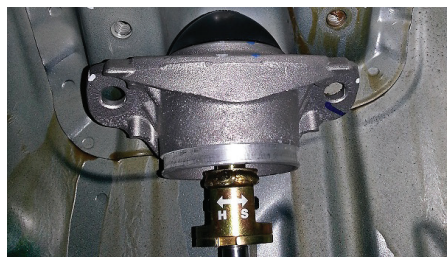

fig. 17

CAUTION

TORQUE-TO-YIELD BOLTS ARE DESIGNED TO BE REPLACED AFTER LOOSENING. TORQUE TO YIELD BOLTS HAVE AN ANGULAR TORQUE IN ADDITION TO THE TORQUE SPECIFICATION.

3. Lift the control arm, align the shock eye and attach with the shock eye bolt and nut. Do not torque at this time (Fig. 18).



fig. 18

4. Align the stabilizer end link and slide the bolt through the control arm and cap with the previously removed nut. Torque to 45Nm (33 lb.-ft.) (Fig. 19).



fig. 19

5. Apply thread sealant to the threads of the appropriate fitting. Tighten the fitting to the air spring 1-3/4 turns beyond hand-tight (Fig. 20).



fig. 20

- Place the roll plate on the bottom of the air spring. Install two 3/8"-24 x 7/8" hex bolts with lock washers through the spring seat into the air spring. Torque to 27Nm (20 lb.-ft.) (Fig. 21).



fig. 21

- Insert the assembly into the spring pocket with the air fitting pointed away from the wheel. Nest the upper roll plate over the air spring assembly (Figs. 22 & 23).



fig. 22



fig. 23

8. Attach the air line. Leave the air line loose until the air spring installation is complete.
9. Install a 3/8" lock washer and 3/8"-24 x 2" hex cap screw and insert through the centering spacer and the factory lower spring seat and thread into the provided spring seat. Torque the bolt to 27Nm (20 lb.-ft.) (Fig. 24).

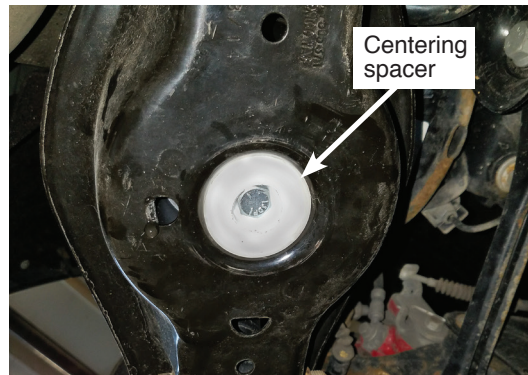

fig. 24

10. Reinstall the headlight alignment linkage if equipped.

ROUTING THE AIR LINES

1. Fully compress the suspension using a jack. With the suspension compressed, review the best routing for the air line that is clear of all suspension components and axle.
2. Make sure the air line so that it will not bind with the stabilizer bar end link.
3. Routing should also allow for the suspension to extend without kinking or pulling the line tight or rubbing on other components. Check clearances to all other components.

Finished Installation



fig. 25

Tips for Installing the Air Lines

CUTTING AIR LINES

When cutting air lines, use a sharp knife or a hose cutter and make clean, square cuts (Fig. 26). Do not use scissors or wire cutters because these tools will deform the air line, causing it to leak around fittings. Do not cut the lines at an angle.

The minimum bend radius for 1/4" air line is 1" (25mm). The minimum bend radius for 3/8" air line is 1.5" (38mm). Do not bend the air line less than the minimum bend radius or side load the fitting connections. Air lines are to be installed straight into fittings.

Inspect the air line for scratches that run lengthwise prior to installation. Contact Air Lift customer service at (800) 248-0892 if the air line is damaged.



To watch a video demonstrating proper air line cutting, go to air-lift.co/cuttingairline

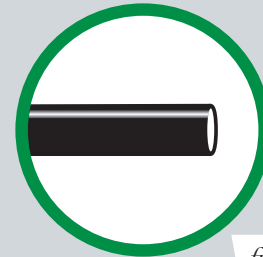

fig. 26



PUSH-TO-CONNECT (PTC) FITTINGS

Air lines should be pushed into the push-to-connect fittings firmly, with a slight side-to-side rotational twist. Check the connection by pulling on each line to verify a robust connection.

NOTE

To release the air line from the connection (Fig. 27), first release all air from the system. Push in on the air line (step 1), push the collar in (step 2), and with the collar depressed, pull the air line out of the fitting (step 3).

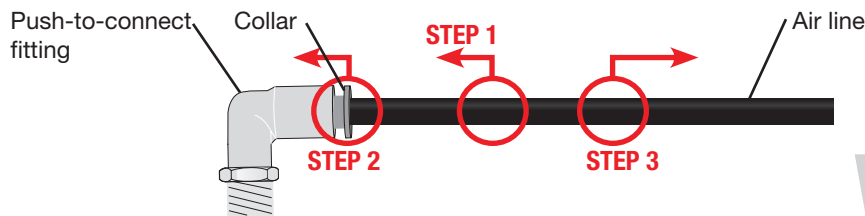

fig. 27

CHECKING FOR LEAKS

1. Inflate the air spring to 75-90 PSI (5.2-6.2BAR).
2. Spray all connections with a solution of liquid dish soap and water. Spot leaks easily by looking for bubbles in the soapy water.
3. After the test, deflate the springs to the minimum pressure required to restore the system to normal ride height.
4. Check the air pressure again after 24 hours. A 2-4 PSI (.14-.28BAR) loss after initial installation is normal. Retest for leaks if the loss is more than 5 PSI (.34BAR).

FIXING LEAKS

1. If there is a problem with the push-to-connect fitting, remove the air line as described above. Trim 1" (25mm) off the end of the air line. Be sure the cut is clean and square (see Fig. 26).
2. Reinsert the air line into the push-to-connect fitting as described above.

Before Operating

SETTING THE RIDE HEIGHT

1. With the suspension fully compressed, take a measurement from the fender to a chosen reference point – typically the center of the axle. Record this measurement as max compression (MC).
2. Cycle the suspension to max extension (ME) and record the measurement from the fender to the same reference point.
3. Add ME and MC, then divide the total by 2. Set the suspension to this point. This position will give 50% stroke in either direction and is a starting point for ride height (Fig. 28).

Formula for Calculating Ride Height

$(ME+MC) \div 2 = \text{MID STROKE}$

fig. 28

4. With the suspension at this position, loosen, then re-torque all suspension bushing pivot joint fasteners to the manufacturer’s specifications (Table 1):

Torque Specifications		
Location	Nm	lb-ft
Lower control arm cam bolt	95	70
Lower control arm to stabilizer end link bolt	45	33
Lower control arm to shock eye bolt	95	70
Lower control arm to hub	90 + 90 degrees	66 + 90 degrees
Shock mount to chassis	50 + 90 degrees	37 + 90 degrees
Shock rod nut	27	20
Upper transverse link to subframe	95	70
Upper transverse link to hub	130 + 90 degrees	96 + 90 degrees
Tie rod to subframe	90 + 90 degrees	66 + 90 degrees
Tie rod to hub	130 + 90 degrees	96 + 90 degrees
Wheel studs	120	89
Braided air line threads	1-3/4 turns beyond hand-tight	

Table 1



TORQUE-TO-YIELD BOLTS ARE DESIGNED TO BE REPLACED AFTER LOOSENING. TORQUE TO YIELD BOLTS HAVE AN ANGULAR TORQUE IN ADDITION TO THE TORQUE SPECIFICATION.

Suggested Driving Air Pressure	Maximum Air Pressure
45-80 PSI (3.1-4/5.5BAR)	125 PSI (8.6BAR)
FAILURE TO MAINTAIN ADEQUATE MINIMUM PRESSURE (OR PRESSURE PROPORTIONAL TO LOAD) MAY RESULT IN EXCESSIVE BOTTOMING OUT AND WILL VOID THE WARRANTY.	

Table 2

CHECK FOR BINDING

1. Inflate and deflate the system (do not exceed 125 PSI [8.6BAR]) to check for clearance or binding issues. With the air springs deflated, check clearances on everything so as not to pinch brake lines, vent tubes, etc. Clear lines if necessary.
2. Inflate the air springs to 75-90 PSI (5.2-6.2BAR) and check all connections for leaks.

DAMPING ADJUSTMENT

Suspension damping is a matter of compromise. Setting it too stiff will make the ride feel jarring. In addition, if the suspension is too stiff, the tires will lose contact with the road, reducing control and power delivery. On the other hand, if the suspension is too soft, the car can experience brake dive and excessive bouncing. The sweet spot lies somewhere in the middle. Air Lift dampers have a range of adjustment, which allows the driver to tune the ride and handling to his or her preferences.

Air Lift recommends damper and air pressure settings for every vehicle kit, but it is impossible to consider every situation. For example, even though Air Lift kits replace the dampers and springs, vehicles with sport-tuned suspensions might have stiffer bushings, larger anti-roll bars, bigger wheels, wider tires, etc. These settings may need to be adjusted to different vehicles and driving characteristics.

1. The dampers in this kit have 30 settings, or “clicks,” of adjustable compression and rebound damping characteristics. Damping is changed through the damper rod using the supplied adjuster (Fig. 29).
2. Turn the adjuster clockwise (H) and the damping settings are hardened, reducing oscillations and body motion. Turn the adjuster counterclockwise (S) and the damping is softened.
3. Each damper in this kit is preset to “-15 clicks.” This means that the damper is adjusted 15 clicks away from full stiff, which starts at 0. Counting up from full stiff is the preferred method of keeping track of, or setting, damping. This setting was developed on a 2015 Volkswagen Golf GTI with stock suspension.

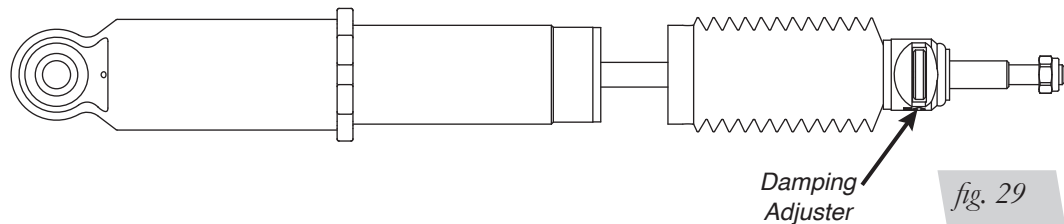

ALIGNING THE VEHICLE

1. Set the vehicle to the height at which it will most often be driven.
2. If the ride height is lower than stock, Air Lift Performance recommends loosening all pivot points (bolts, nuts) on any control arm, strut arm or radius rod that contains bushings. Once they have been loosened, re-torque to stock specifications (Table 1).

NOTE

It may be necessary to cycle the suspension to loosen the bushing from its mount. This will help re-orient the bushing at its new position based on the chosen ride height.

3. Get a shop alignment of the vehicle at the new chosen ride height.

INSTALLATION CHECKLIST

- Clearance** — Inflate the air springs to 75-90 PSI (5.2-6.2BAR) and make sure there is at least 1/2" (13mm) clearance from anything that might rub against the air spring. This should be checked with the air spring fully inflated and fully deflated.
- Leak** — Inflate the air springs to 75-90 PSI (5.2-6.2BAR) and check all connections for leaks. All leaks must be eliminated before the vehicle is road tested.
- Heat** — Be sure there is sufficient clearance from heat sources, at least 6" (150mm) for air springs and air lines. If a heat shield was included in the kit, install it. If there is no heat shield, but one is required, call Air Lift customer service at **(800) 248-0892**.
- Fastener** — Recheck all bolts for proper torque.
- Road** — Inflate the springs to recommended driving pressures. Drive the vehicle 10 miles (16km) and recheck for clearance, loose fasteners and air leaks.
- Operating instructions** — If professionally installed, the installer should review the operating instructions with the owner. Be sure to provide the owner with all paperwork that came with the kit.

POST-INSTALLATION CHECKLIST

- Overnight leak down test** — Recheck air pressure 24 hours after installation and driving of the vehicle. If the pressure has dropped more than 5 PSI (.34BAR), there is a leak that must be fixed.
- Air pressure requirements** — It is important to understand the air pressure requirements of the air spring system. Regardless of load, the air pressure should always be adjusted to maintain adequate ride height at all times while driving.
- Thirty-day or 500-mile (800km) test** — Recheck the air spring system after 30 days or 500 miles (800km), whichever comes first. If any part shows signs of rubbing or abrasion, the source should be identified and moved, if possible. If it is not possible to relocate the cause of the abrasion, the air spring may need to be remounted. If professionally installed, the installer should be consulted. Check all fasteners for tightness.

Use, Maintenance and Servicing

1. An Air Lift air management system is strongly recommended for this product, but it is possible to operate without one. The air lines can be routed to Schrader valves for use with a separate air compressor. Air lines and Schrader valves are not included with Air Lift Performance kits and would need to be purchased separately. To learn more about Air Lift management systems visit air-lift.co/productlines.
2. Check the air pressure before driving.

 **WARNING**

BEFORE SERVICING THE VEHICLE, MAKE SURE TO TURN OFF “RISE ON START” AND “PRESET MAINTAIN.” THIS WILL ELIMINATE ANY UNINTENDED SUSPENSION CYCLING IF YOU NEED TO TURN THE KEY ON IN THE VEHICLE FOR ANY REASON.

TUNING THE AIR PRESSURE.

Pressure determination comes down to three things — level vehicle, ride comfort and stability.

1. Level vehicle

Depending on load, it is possible one side will need more pressure than the other to level the vehicle.

2. Ride comfort

If the vehicle has a harsh ride, it may be due to either too much pressure or not enough causing frequent bottoming. Also, riding the vehicle at the top, or close to the top of the available stroke will cause an uncomfortable ride due to a lack of rebound travel. This situation should be avoided for driving any significant distance. Try different pressures to determine the best ride comfort. See the Air Lift suggested driving air pressure for this vehicle (Table 2).

3. Stability

Stability translates into safety and should be the priority, meaning the driver may need to sacrifice a perfectly level and comfortable ride. Stability issues include roll control, bounce, dive during braking and sponginess. Tuning out these problems usually requires additional air pressure, damping or both.

Troubleshooting Guide

PROBLEM	CAUSE	SOLUTION
Air spring won't maintain pressure.	Leak at fitting, air line not cut properly or damage to air line during installation.	Find location of leak by spraying listed components with soapy water solution and look for bubbles. Tighten air fitting, re-cut air line or replace damaged components.
	Leak at lower O-ring on damper if air spring is over the damper.	Spray bottom of air spring with soapy water solution and look for bubbles. Contact Air Lift customer service at (800) 248-0892 to determine if component should be replaced.
Knocking noise when hitting bumps.	Loose suspension component such as locking collar on damper.	Tighten lower locking collar with significant force, check and tighten suspension components to factory specs at desired ride height.
	Driving vehicle too close to maximum extension.	Check current ride height and compare to maximum height. If there is less than 1" (25mm) difference, reduce air pressure to lower ride height.
		Lengthen strut or shock to increase available up travel.
Suspension bottoms out.	Air pressure is too low, causing air springs to bottom out.	Raise air pressure.
The ride is too bouncy.	Air pressure is too high, causing air springs to be too stiff.	Lower air pressure and adjust damper length if necessary to achieve proper ride height.
	Damping is inadequate.	Increase damping with adjusters.
The ride is too soft or floaty.	Damping is inadequate.	
The ride is too harsh.	Excessive damping.	Reduce damping with adjusters.

Notes

Limited Warranty and Return Policy

Air Lift Company provides a 1-year limited warranty to the original purchaser of Air Lift Performance damper kits from the date of original purchase, that the products will be free from defects in workmanship and materials when used on vehicles as specified by Air Lift Company and under normal operating conditions, subject to the requirements and exclusions set forth in the full Limited Warranty and Return Policy that is available online at www.airliftperformance.com/warranty.

For additional warranty information contact Air Lift Company customer service.

Replacement Part Information

If replacement parts are needed, call Air Lift customer service. Most parts are immediately available and can be shipped the same day.

Contact Air Lift Company customer service at (800) 248-0892 first if:

- Parts are missing from the kit.
- Need technical assistance on installation or operation.
- Broken or defective parts in the kit.
- Wrong parts in the kit.
- Have a warranty claim or question.

Contact the retailer where the kit was purchased:

- If it is necessary to return or exchange the kit for any reason.
- If there is a problem with shipping if shipped from the retailer.
- If there is a problem with the price.

Contact Information

Mailing address	P.O. Box 80167 Lansing, MI 48908-0167
Shipping address for returns	2727 Snow Road Lansing, MI 48917
Phone	Toll free: (800) 248-0892 International: (517) 322-2144
Email	service@airliftcompany.com
Web address	www.airliftcompany.com

Air Lift Company reserves the right to make changes and improvements to its products and publications at any time. For the latest version of this manual, contact Air Lift Company at **(800) 248-0892** or visit **www.airliftperformance.com**.

Need Help?

Contact Air Lift Company customer service department by calling (800) 248-0892. For calls from outside the USA or Canada, dial (517) 322-2144.



Connect by searching for **Air Lift Performance** #LifeonAir



Thank you for purchasing Air Lift Performance products!

Air Lift Performance • 2727 Snow Road • Lansing, MI 48917 or P.O. Box 80167 • Lansing, MI 48908-0167
Toll Free (800) 248-0892 • Local (517) 322-2144 • Fax (517) 322-0240 • www.airliftperformance.com

Printed in the USA
JPR_0717