

**Kit 78588**

**BMW G20**  
**FRONT APPLICATION**

For maximum effectiveness and safety, please read these instructions completely before proceeding with installation.

*Failure to read these instructions can result in an incorrect installation which could result in damage to the vehicle, minor to severe personal injury or death.*



**Watch the video**

Info on Table of Contents page



# TABLE OF CONTENTS

## P.02

### Introduction

- 02. Notation Explanation
- 

## P.03

### System Overview

## P.04

### Installing the System

- 04. Important Safety Notices
  - 04. Section 1. Prepare the Vehicle
  - 05. Section 2. Remove the Front Damper
  - 07. Section 3. Install the Air Suspension
  - 09. Section 4. Route the Air Lines
  - 10. Finished Installation
- 

## P.11

### Before Operating

- 11. Set the Ride Height
  - 11. Torque Specifications
  - 11. Suggested Driving Air Pressure
  - 11. Maximum Air Pressure
  - 11. Check for Binding
  - 12. Installation Checklist
  - 12. Damping Adjustment
- 

## P.13

### Limited Warranty and Return Policy

## Video-enhanced installation guides

Visit [airliftcompany.com/workshop/category/install-videos](http://airliftcompany.com/workshop/category/install-videos) to access our installation video archive\*.

\* subject to availability

# Introduction

Air Lift Performance thanks you for purchasing the most complete, fully engineered high-performance air suspension made for the BMW G20. Read these installation instructions to correctly and safely set up the vehicle for a #lifeonair.

Air Lift assumes that the installer has the mechanical knowledge and ability to work on vehicle suspension systems and has basic tools necessary to complete a suspension replacement project. Special tools needed to complete the installation are noted on the *System Overview* page.

Air Lift reserves the right to make changes and improvements to its products and publications at any time. For the latest version of this manual, contact Air Lift Performance at **(800) 248-0892** or visit **[www.airliftperformance.com](http://www.airliftperformance.com)**.

An Air Lift Performance air management system is highly recommended for this product. Learn more at **[air-lift.co/productlines](http://air-lift.co/productlines)**.

## NOTATION EXPLANATION

Hazard notations appear in various locations in this publication. Information which is highlighted by one of these notations must be observed to help minimize risk of personal injury or possible improper installation which may render the vehicle unsafe. Notes are used to help emphasize areas of procedural importance and provide helpful suggestions. The following definitions explain the use of these notations as they appear throughout this guide.



### **DANGER**

INDICATES IMMEDIATE HAZARDS WHICH WILL RESULT IN SEVERE PERSONAL INJURY OR DEATH.



### **WARNING**

INDICATES HAZARDS OR UNSAFE PRACTICES WHICH COULD RESULT IN SEVERE PERSONAL INJURY OR DEATH.



### **CAUTION**

INDICATES HAZARDS OR UNSAFE PRACTICES WHICH COULD RESULT IN DAMAGE TO THE VEHICLE OR MINOR PERSONAL INJURY.



### **NOTE**

*Used to help emphasize areas of procedural importance and provide helpful suggestions.*

# System Overview

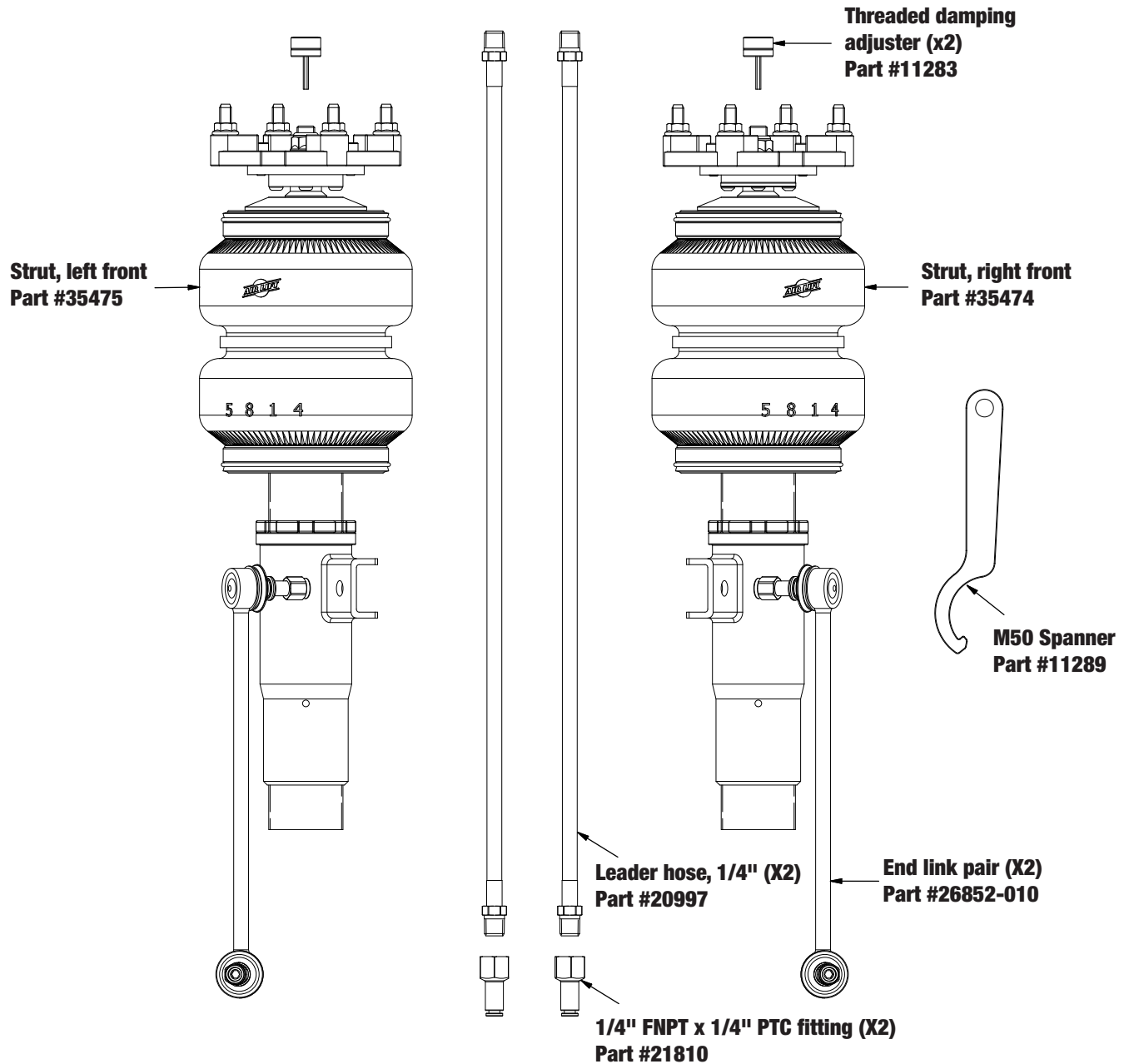

**CAUTION**

THIS KIT REQUIRES THE REMOVAL OF FACTORY TORQUE-TO-YIELD BOLTS. THESE BOLTS ARE DESIGNED TO BE REPLACED AFTER THEY HAVE BEEN LOOSENED. TORQUE-TO-YIELD BOLTS ARE INDICATED IN THE INSTRUCTIONS AND IN THE TORQUE SPECIFICATION CHART.



Missing or damaged parts? Call Air Lift customer service at (800) 248-0892 for a replacement part.

# Installing the System

## IMPORTANT SAFETY NOTICES



DO NOT INFLATE AIR SPRINGS WHILE OFF OF THE VEHICLE. DAMAGE TO ASSEMBLY MAY RESULT AND VOID WARRANTY.



DO NOT WELD TO OR MODIFY PERFORMANCE STRUTS/SHOCKS IN ANY WAY. DAMAGE TO UNIT MAY OCCUR AND WILL VOID WARRANTY.



AFTER INSTALLATION, ENSURE ALL ORIGINAL EQUIPMENT VEHICLE SAFETY FEATURES ARE PROPERLY CALIBRATED BY A QUALIFIED TECHNICIAN. CHANGING VEHICLE HEIGHT MAY AFFECT FUNCTIONING OF SAFETY SENSORS AND CAMERAS.

## SECTION 1.

### PREPARE THE VEHICLE



RAISE THE FRONT OF THE VEHICLE WITH A JACK AT THE APPROVED LIFTING POINTS AND USE SAFETY STANDS TO SUPPORT THE VEHICLE.

1. Elevate and support the vehicle with a hoist or jack stands.
2. Remove the front wheel.

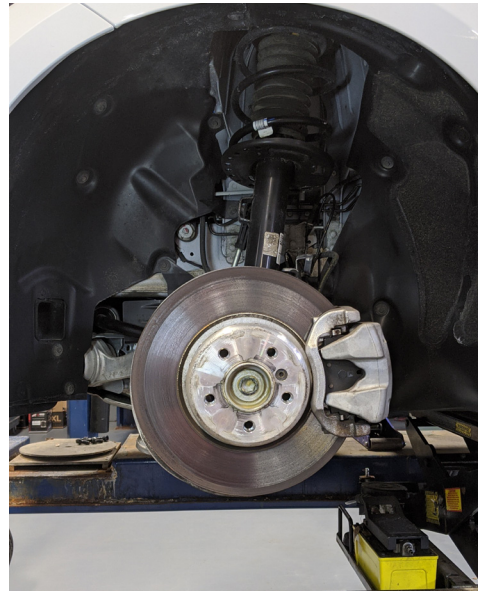

## SECTION 2.

## REMOVE THE FRONT DAMPER

1. Disconnect the sensor linkage from the lower control arm.

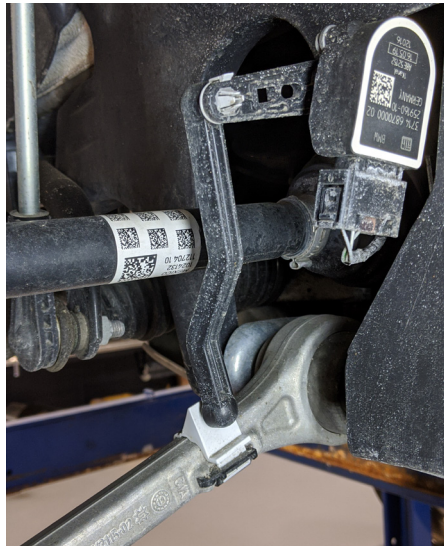

2. Remove the screw securing the splash guard and unbolt the lower control arm from the subframe.

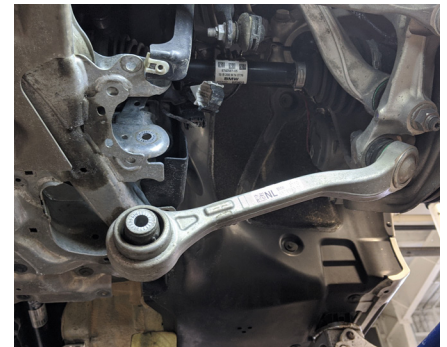

3. Unbolt the stabilizer link from the damper assembly and stabilizer bar.



- Support the hub assembly, loosen and remove the lower pinch bolt from the wheel bearing housing. Lower the assembly until the strut body is free from the wheel bearing housing. Be aware of sensor bracket wiring orientation/location for reinstallation.



- Within the engine compartment, unlock/lift the cowl cover. Remove the pins from the weather-stripping trim and lift to gain access to the upper mount bolts.

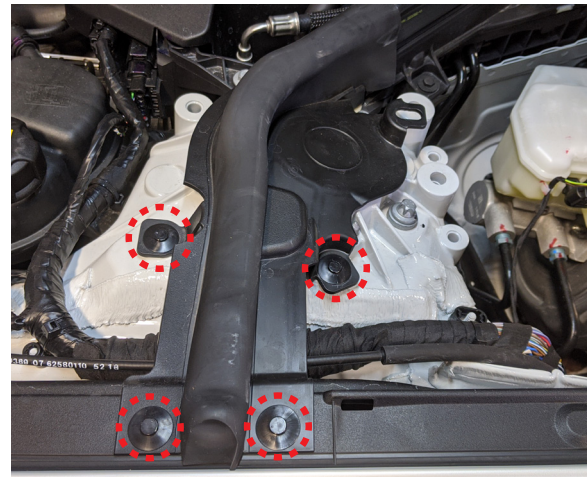

- Remove the four upper mount bolts and remove the damper assembly from the vehicle.

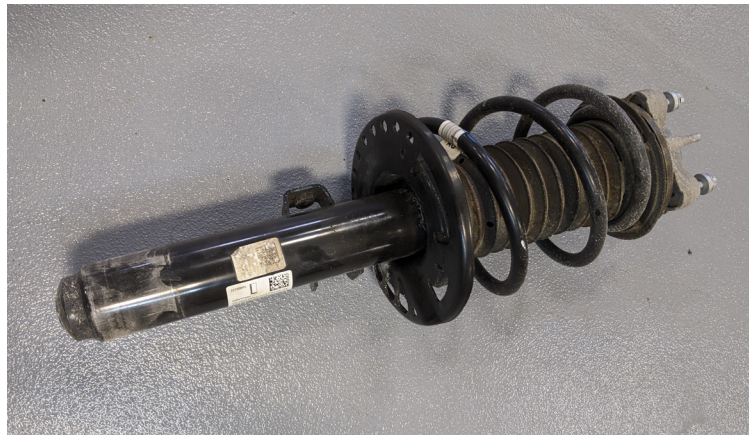
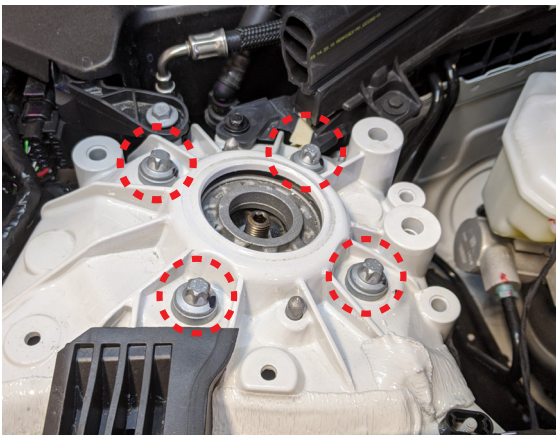



## **SECTION 3.** INSTALL THE AIR SUSPENSION

1. Begin applying thread sealant to the threads of the leader line. Tighten the fitting to the air line (1 3/4 turns beyond hand-tight). Tighten the leader line into the air spring 1 3/4 turns beyond hand-tight.

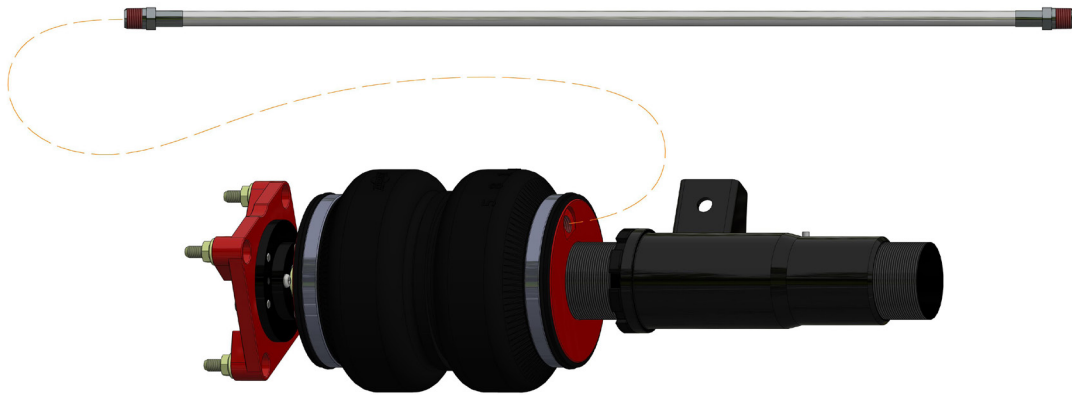

2. Attach the upper mount to the chassis. Torque nuts to 28Nm (21 lb.-ft.).

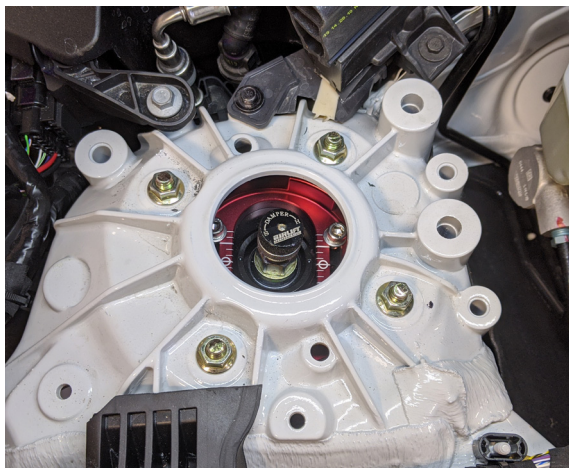

3. Reinstall the weather-stripping trim and cowl cover.

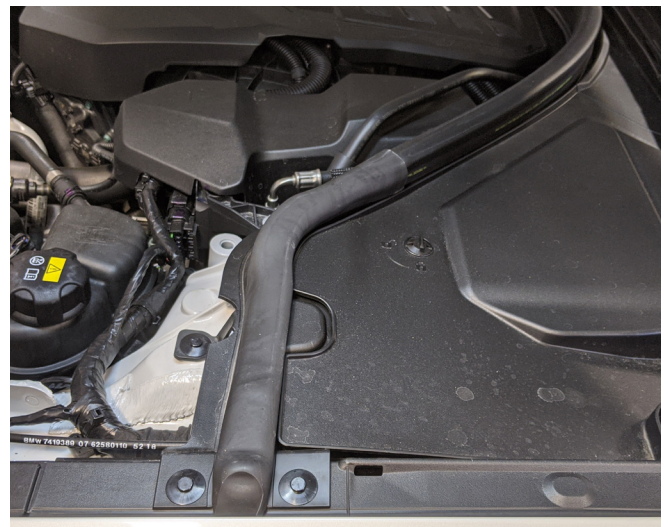
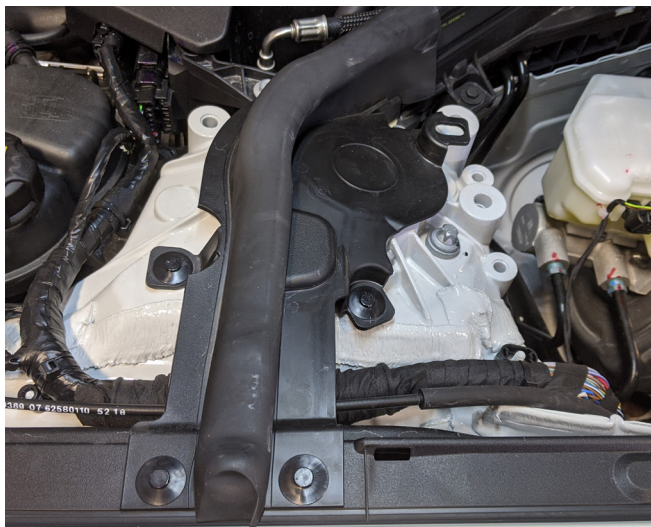

- Lift the hub assembly onto the damper, reinstall the sensor wire bracket to its original location, and attach the lower pinch bolt. Torque to 56Nm + 90 degrees (41 lb.-ft. + 90 degrees).

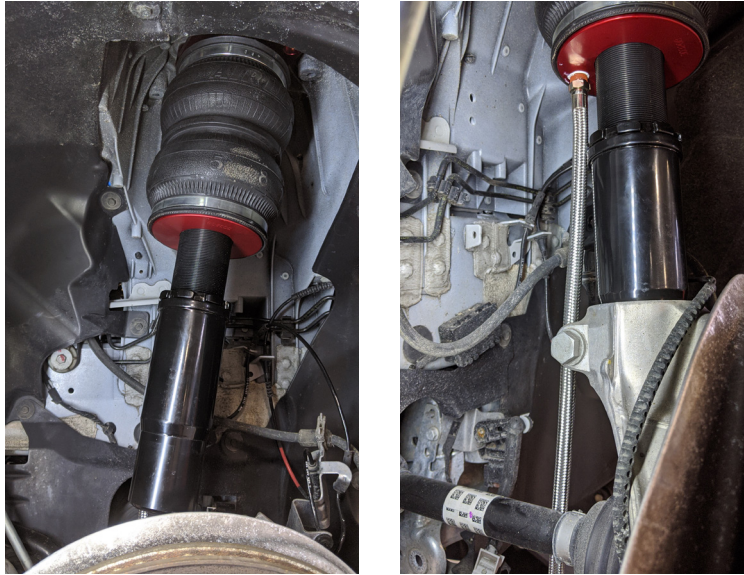

- Align and reattach the lower control arm to the subframe. Do not torque at this time.

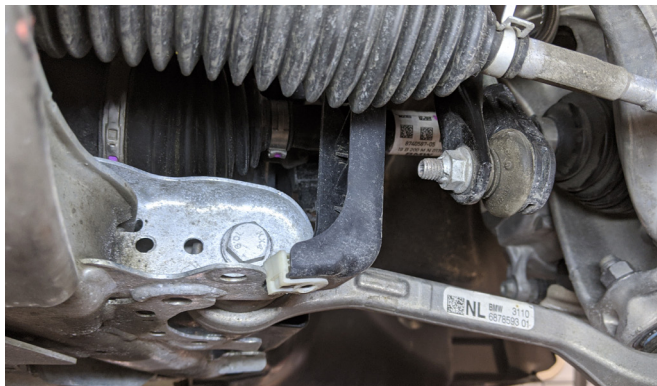

- Attach the supplied stabilizer end link to the damper and stabilizer bar. Torque the end link nuts to 56Nm (41lb.-ft.).



7. Reattach the sensor linkage to the lower control arm.



8. Torque the lower control arm to the subframe at ride height with suspension loaded. Torque to 100Nm + 90 degrees (74 lb.-ft. + 90 degrees).
9. Reattach the splash guard.

## SECTION 4.

### ROUTE THE AIR LINES



AFTER INSTALLATION, ENSURE ALL ORIGINAL EQUIPMENT VEHICLE SAFETY FEATURES ARE PROPERLY CALIBRATED BY A QUALIFIED TECHNICIAN. CHANGING VEHICLE HEIGHT MAY AFFECT FUNCTIONING OF SAFETY SENSORS AND CAMERAS.

1. Fully compress the suspension using a jack. With the suspension compressed, review the best routing for the air line that is clear of all suspension and steering components.
2. Routing should allow for the suspension to extend and steer without kinking, pulling the line tight or rubbing on other components. Following the brake line routing is often a good place to start. Check clearances to all other components.

# Finished Installation

The image shows the finished installation.



## Congratulations!

You are now the proud owner of an industry leading Air Lift Performance air suspension system. Enjoy!

# Before Operating

## SET THE RIDE HEIGHT

1. Refer to the User Guide supplied with this kit to set up the suspension.

Torque Specifications			
Location	Nm	lb.-ft.	lb.-in.
Upper mount to chassis	28	21	
Damper lower pinch bolt	TTY 56 + 90 degrees	TTY 41 + 90 degrees	
Stabilizer linkage to damper	56	41	
Control arm to subframe	TTY 100 + 90 degrees	TTY 74 + 90 degrees	
Wheel bolts	140	103	
Camber adjustment bolt	7	5.2	62
Damper locking collar	45 degrees beyond hand-tight		
Air line and fitting	1 3/4 turn beyond hand-tight with thread sealant		



TORQUE-TO-YIELD BOLTS ARE DESIGNED TO BE REPLACED AFTER THEY HAVE BEEN LOOSENED.

2. Upon successful completion of the installation, follow these pressure requirements for the air springs.



**Suggested Driving Air Pressure**



**Maximum Air Pressure**



FAILURE TO MAINTAIN ADEQUATE MINIMUM PRESSURE (OR PRESSURE PROPORTIONAL TO LOAD) MAY RESULT IN EXCESSIVE BOTTOMING OUT AND **WILL VOID THE WARRANTY.**

## CHECK FOR BINDING



MAKE SURE THE FRONT WHEELS ARE STRAIGHT WHEN DEFLATING AND REINFLATING AIR SPRINGS.

1. Inflate and deflate the system (do not exceed 125 PSI [8.6BAR]) to check for clearance or binding issues. With the air springs deflated, check clearances on everything so as not to pinch brake lines, vent tubes, etc. Clear lines if necessary.
2. Inflate the air springs to 75-90 PSI (5.2-6.2BAR) and check all connections for leaks.

## INSTALLATION CHECKLIST

- Clearance** — Inflate the air springs to 75-90 PSI (5.2-6.2BAR) and make sure there is at least 1/2" (13mm) clearance from anything that might rub against the air spring. This should be checked with the air spring fully inflated and fully deflated.
- Leak** — Inflate the air springs to 75-90 PSI (5.2-6.2BAR) and check all connections for leaks. All leaks must be eliminated before the vehicle is road tested.
- Heat** — Be sure there is sufficient clearance from heat sources, at least 6" (152mm) from air springs and air lines. If a heat shield was included in the kit, install it. If there is no heat shield, but one is required, call Air Lift customer service at **(800) 248-0892**.
- Fastener** — Recheck all bolts for proper torque.
- Road** — Inflate the air springs to recommended driving pressures (see previous page). Drive the vehicle 10 miles (16km) and recheck for clearance, loose fasteners and air leaks.
- Operating instructions** — If professionally installed, the installer should review the operating instructions with the owner. Be sure to provide the owner with all paperwork that came with the kit.

## DAMPING ADJUSTMENT

1. The dampers in this kit have 30 settings, or “clicks,” of adjustable compression and rebound damping characteristics. Damping is changed through the damper rod using the supplied adjuster (example shown here) or a 3mm hex key (not included).

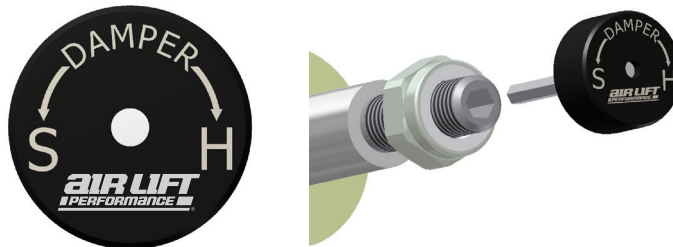

2. Turn the adjuster clockwise (H) and the damping settings are hardened, reducing oscillations and body motion. Turn the adjuster counterclockwise (S) and the damping is softened.
3. Each damper in this kit is preset to “-15 clicks.” This means that the damper is adjusted 15 clicks away from full stiff, which starts at 0. Counting up from full stiff is the preferred method of keeping track of, or setting, damping. This setting was developed on a 2020 BMW 330XI.

For more information, refer to the User Guide.

# Limited Warranty and Return Policy

Air Lift Company provides a 1-year limited warranty to the original purchaser of Air Lift Performance damper kits from the date of original purchase, that the products will be free from defects in workmanship and materials when used on vehicles as specified by Air Lift Company and under normal operating conditions, subject to the requirements and exclusions set forth in the full Limited Warranty and Return Policy that is available online at [www.airliftperformance.com/warranty](http://www.airliftperformance.com/warranty).

For additional warranty information contact Air Lift Company customer service.

*Thank you for purchasing Air Lift Performance products!*

## Need Help?

The Air Lift Company customer service department is open from 8 a.m. to 8 p.m. ET Monday through Friday. Call (800) 248-0892 or (517) 322-2144 for calls from outside the U.S. and Canada.



CONNECT BY SEARCHING FOR **AIR LIFT PERFORMANCE** #LIFEONAIR

**AIR LIFT**  
PERFORMANCE

2727 Snow Road Lansing, MI 48917 or P.O. Box 80167 Lansing, MI 48908-0167  
Toll Free (800) 248-0892 • Local (517) 322-2144 • Fax (517) 322-0240  
[www.airliftperformance.com](http://www.airliftperformance.com)



MADE IN USA  
WITH GLOBAL  
COMPONENTS

Air Lift Company reserves the right to make changes and improvements to its products and publications at any time. For the latest version of this manual, contact Air Lift Company at (800) 248-0892 or visit [airliftperformance.com](http://airliftperformance.com).