

**AIR LIFT**  
**PERFORMANCE**

# Kit 75690

Volkswagen MKV & MKVI  
*Independent Rear Application*



## INSTALLATION GUIDE

For maximum effectiveness and safety, please read these instructions completely before proceeding with installation.

*Failure to read these instructions can result in an incorrect installation.*





## TABLE OF CONTENTS

<b>Introduction</b> .....	<b>2</b>
Notation Explanation .....	2
<b>Important Safety Notices</b> .....	<b>2</b>
<b>Installation Diagram</b> .....	<b>3</b>
Hardware List .....	3
<b>Installing the Air Suspension</b> .....	<b>4</b>
Preparing the Vehicle .....	4
Installing the Kit Components .....	4
Routing the Air Lines .....	9
<b>Before Operating</b> .....	<b>9</b>
Torque Specifications .....	9
Suggested Driving Air Pressure and Maximum Air Pressure .....	9
Installation Checklist .....	10
<b>Maintenance and Use Guidelines</b> .....	<b>10</b>
<b>Limited Warranty and Return Policy</b> .....	<b>12</b>



# Introduction

Air Lift Performance thanks you for purchasing the most complete, fully engineered high-performance air suspension made for the Volkswagen MKV and MKVI. Read these installation instructions to correctly and safely set up the vehicle for a #lifeonair.

Air Lift assumes that the installer has the mechanical knowledge and ability to work on vehicle suspension systems and has basic tools necessary to complete the project. Special tools needed to complete the installation are noted on the Installation Diagram page.

Air Lift Performance reserves the right to make changes and improvements to its products and publications at any time. For the latest version of this manual, contact Air Lift Performance at (800) 248-0892 or visit [www.airliftperformance.com](http://www.airliftperformance.com).

An Air Lift air management system is highly recommended for this product. Learn more at [air-lift.co/productlines](http://air-lift.co/productlines).

## NOTATION EXPLANATION

Hazard notations appear in various locations in this publication. Information which is highlighted by one of these notations must be observed to help minimize risk of personal injury or possible improper installation which may render the vehicle unsafe. Notes are used to help emphasize areas of procedural importance and provide helpful suggestions. The following definitions explain the use of these notations as they appear throughout this guide.



### DANGER

INDICATES IMMEDIATE HAZARDS WHICH WILL RESULT IN SEVERE PERSONAL INJURY OR DEATH.



### WARNING

INDICATES HAZARDS OR UNSAFE PRACTICES WHICH COULD RESULT IN SEVERE PERSONAL INJURY OR DEATH.



### CAUTION

INDICATES HAZARDS OR UNSAFE PRACTICES WHICH COULD RESULT IN DAMAGE TO THE MACHINE OR MINOR PERSONAL INJURY.

### NOTE

*Indicates a procedure, practice or hint which is important to highlight.*

## Important Safety Notices



### WARNING

DO NOT INFLATE AIR SPRINGS WHILE OFF OF THE VEHICLE. DAMAGE TO ASSEMBLY MAY RESULT AND VOID WARRANTY.



### CAUTION

DO NOT WELD TO, OR MODIFY PERFORMANCE STRUTS/SHOCKS IN ANY WAY. DAMAGE TO UNIT MAY OCCUR AND WILL VOID WARRANTY.

# Installation Diagram

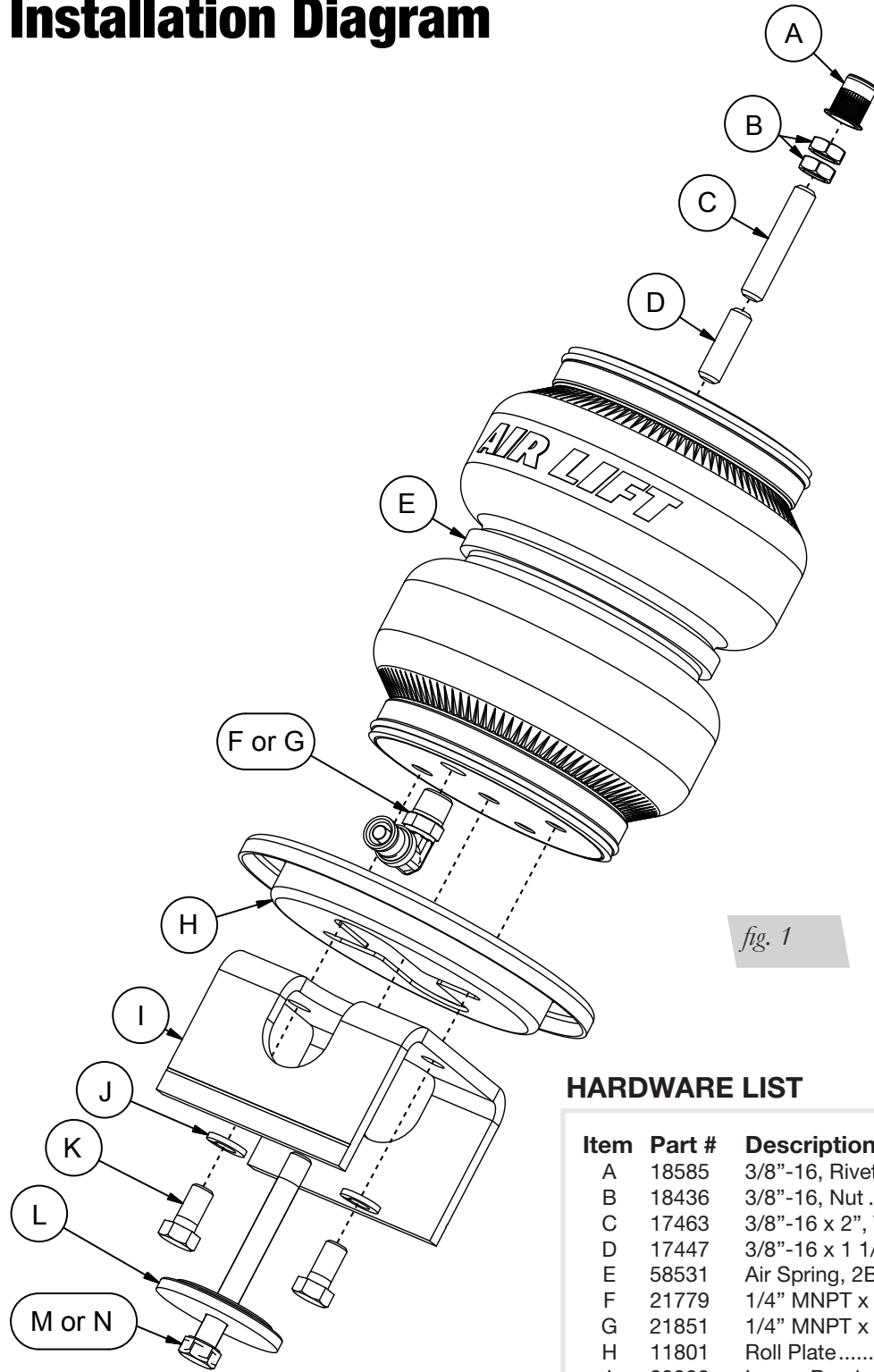

fig. 1

## HARDWARE LIST

Item	Part #	Description	Qty
A	18585	3/8"-16, Rivet Nut .....	2
B	18436	3/8"-16, Nut .....	2
C	17463	3/8"-16 x 2", Threaded Rod.....	2
D	17447	3/8"-16 x 1 1/4", Threaded Rod.....	2
E	58531	Air Spring, 2B6 Reg, Recess Mount .....	2
F	21779	1/4" MNPT x 1/4" PTC Elbow DOT .....	2
G	21851	1/4" MNPT x 3/8" PTC - 90 Degree DOT ....	2
H	11801	Roll Plate.....	2
I	03992	Lower Bracket, MKV Rear.....	2
J	18427	3/8" Lock Washer.....	4
K	17101	3/8"-16 x 3/4" Hex Bolt.....	4
L	13980	Spacer, Spring Seat Centering.....	2
M	17109	3/8"-16 x 3 1/2", Hex Bolt.....	2
N	17442	3/8"-16 x 3", Hex Bolt.....	2



Missing or damaged parts? Call Air Lift customer service at (800) 248-0892 for a replacement part.

# Installing the Air Suspension

**NOTE**

See important safety notices on page 2.

## PREPARING THE VEHICLE

1. Elevate the vehicle and support the body with a hoist or safety stands.
2. Remove the rear wheels.
3. If the vehicle is equipped with automatic vertical headlight control, disconnect the coupling rod from the lower transverse link (Fig. 2).

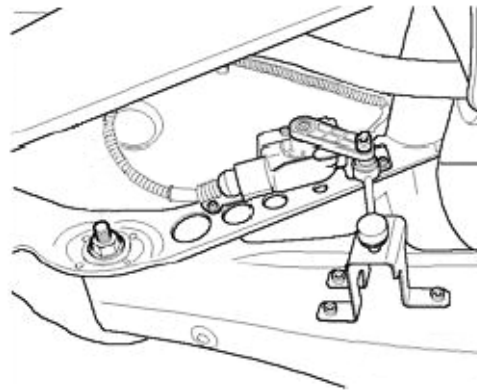

fig. 2

**NOTE**

To remove the coil spring, it is recommended that you use a spring compressor.

**CAUTION**

COIL SPRING UNDER COMPRESSION: THE COIL SPRING CAN BE REMOVED BY SECURELY SUPPORTING THE LOWER TRANSVERSE LINK WITH A JACK AND REMOVING THE LOWER MOUNTING BOLT FROM THE WHEEL BEARING HOUSING. SLOWLY LOWER THE TRANSVERSE LINK UNTIL THE SPRING IS LOOSE AND FREE FROM TENSION.

4. Remove the rubber isolator in the lower transverse link.
5. Disconnect the lower transverse link from the hub.

## INSTALLING THE KIT COMPONENTS

1. Use a 17/32" drill bit to enlarge the hole in the upper coil spring perch. If the upper coil spring perch has been removed, drill in the center of where the perch used to be. The hole must be 17/32" for the rivet nut (A) to be effective (Figs. 3-6).

Factory / OEM Upper Spring Perch

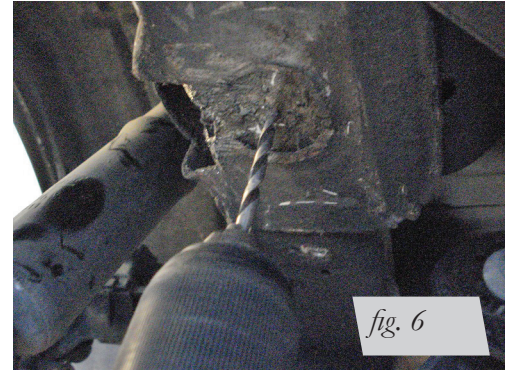

fig. 3

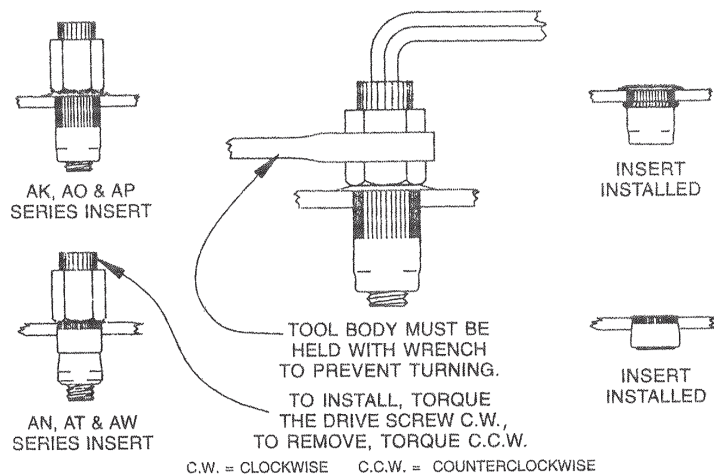

fig. 4

## Previously Cut Spring Perch with Aftermarket Shock



2. Assemble the rivet nut and rivet nut tool together. Insert into the 17/32" hole. Review diagram below on how to attach the rivet nut to the vehicle (Fig. 7).



3. Two lengths of threaded studs are included with the kit (C or D, Fig. 1). The shorter stud is for vehicles that retain the coil spring perch bump. The longer threaded stud is for vehicles without the spring perch bump. Apply thread-locking compound to the threads of the upper end cap and thread in the appropriate stud. Take the supplied nuts (B) and thread both onto one stud (Figs. 8 & 9). Using the nuts jammed together, tighten the stud into the end cap until it bottoms (Fig. 10). Remove both nuts (Fig. 11).

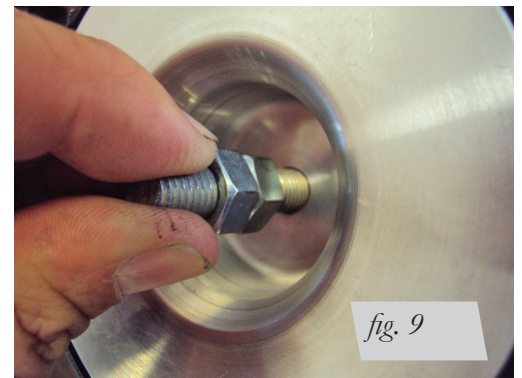
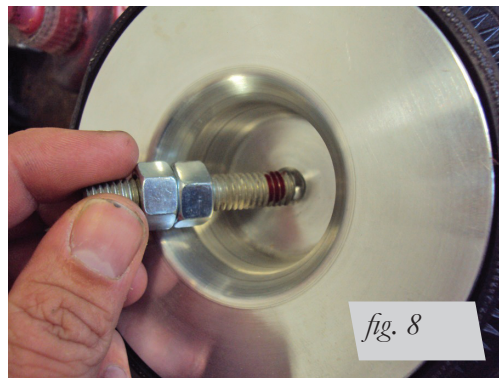

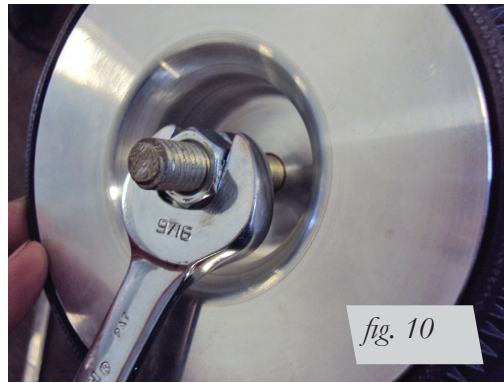

*fig. 10*

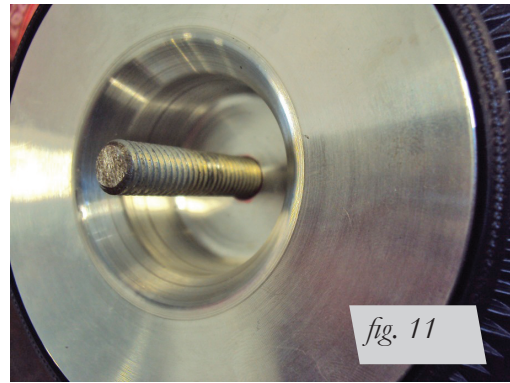

*fig. 11*

4. Wrap the threads of the fitting (F or G) with thread sealant. Tighten the fitting 1 3/4 turns beyond hand tight.
5. Thread the air spring (E) into the rivet nut. Tighten by hand (Figs. 12 & 13 for a factory shock, Figs. 14 & 15 for an aftermarket shock).

Installation With Factory Shock



*fig. 12*

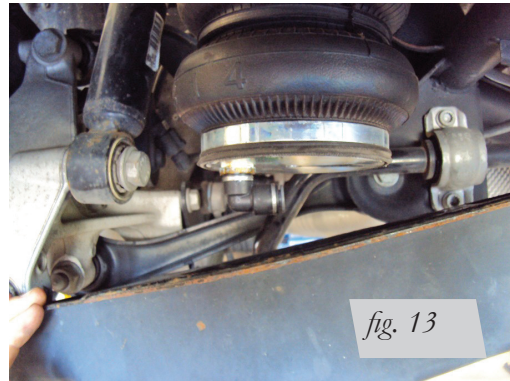

*fig. 13*

Previously Cut Spring Perch with Aftermarket Shock



*fig. 14*



*fig. 15*



- Orient the air fitting inline with lower transverse link toward the center of the vehicle.

## NOTE

*The lower bracket in this kit has a scribe line. This indicates the height the bracket should be if using Air Lift rear shocks or shocks that allow for more drop than the factory shock absorbers with half cut jounce bumpers.*

## CAUTION

**IF RUNNING A SHORTER-THAN-FACTORY SHOCK, THE BRACKET MUST BE TRIMMED DOWN TO PREVENT THE AIR SPRING FROM BEING OVER COMPRESSED AND POTENTIALLY CAUSING A RUPTURE.**

- Attach the lower bracket (I) and roll plate (H) with the lock washer (J) and hex bolts (K) provided. The roll plate is used with the full length lower bracket. Roll plates are not used with a cut bracket. (See Figs. 16-18 for installation with a factory shock, Figs. 19-22 for aftermarket shock.)

Installation with factory shock, roll plate and un-cut lower bracket

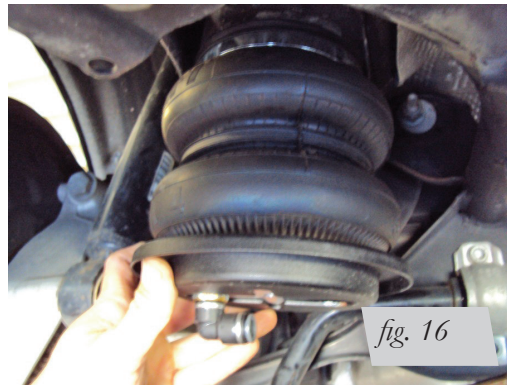

fig. 16

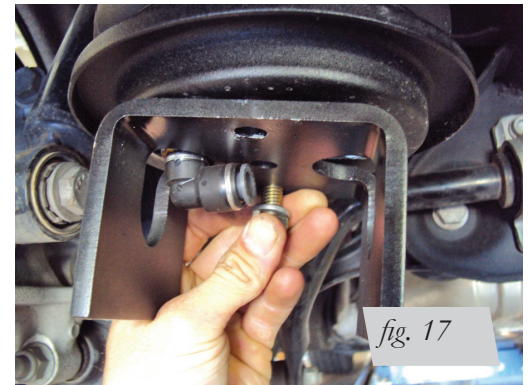

fig. 17

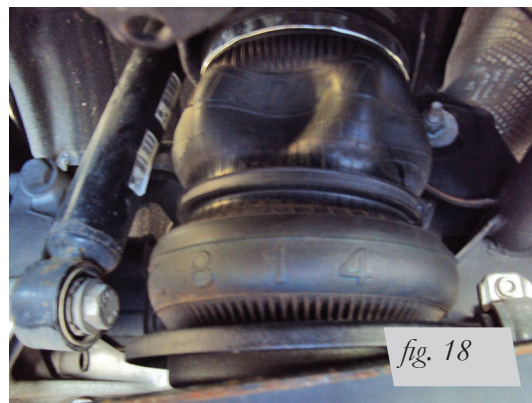
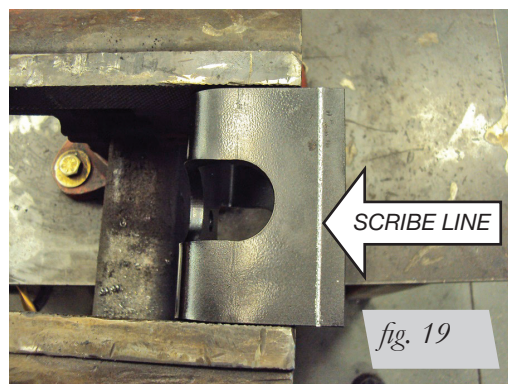

fig. 18

Installation with aftermarket shock, no roll plate and cut bracket



SCRIBE LINE

fig. 19



fig. 20

Installation with aftermarket shock, no roll plate and cut bracket (cont'd)

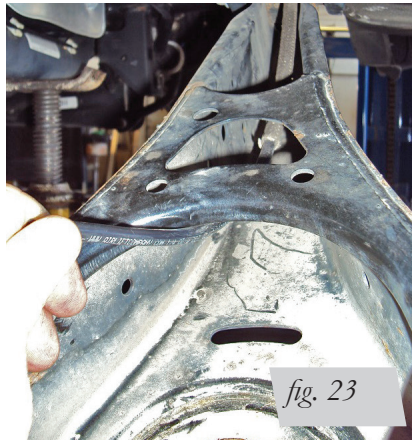

*fig. 21*



*fig. 22*

8. Route the air line from the center of the cross-member, through the lower transverse link and attach insert into the air fitting (Fig. 23). Reattach the lower transverse link to the hub. Do not torque at this time (Fig. 24).



*fig. 23*



*fig. 24*

**NOTE**

*If the lower bracket has been cut, the shorter length bolt should be used to secure the assembly to the lower transverse link with the centering spacer (L) and lock washer. Uncut brackets use the longer bolt (C) (Fig. 25).*



*fig. 25*

## ROUTING THE AIR LINES

1. Fully compress the suspension using a jack. With the suspension compressed, review the best routing for the air line that is clear of all suspension components and axle.
2. Routing should also allow for the suspension to extend without kinking or pulling the line tight or rubbing on other components. Following the brake line routing is often a good place to start. Check clearances to all other components.



**WARNING**

AFTER INSTALLATION, ENSURE ALL ORIGINAL EQUIPMENT VEHICLE SAFETY FEATURES ARE PROPERLY CALIBRATED BY A QUALIFIED TECHNICIAN. CHANGING VEHICLE HEIGHT MAY AFFECT FUNCTIONING OF SAFETY SENSORS AND CAMERAS.

## Before Operating

Read the User Guide that came with this kit to set up the suspension.

Torque Specifications		
Location	Nm	Lb.-ft.
Transverse link to wheel bearing housing	90	66
Transverse link to subframe (toe adjustment)	95	70
Upper control arm to subframe (camber adjustment)	95	70
Upper control arm to wheel bearing housing	130+90 degrees	96+90 degrees
Trailing arm to mounting bracket	90+90 degrees	66+90 degrees
Shock upper mount	45+45 degrees	33+45 degrees
Shock to wheel bearing housing	180	133
Wheels	120	89
Air spring to lower bracket	27	20

*Table 1*

Suggested Driving Air Pressure	Maximum Air Pressure
<b>40-70 PSI (2.8-4.8BAR)</b>	<b>125 PSI (8.6BAR)</b>
<p>FAILURE TO MAINTAIN ADEQUATE MINIMUM PRESSURE (OR PRESSURE PROPORTIONAL TO LOAD) MAY RESULT IN EXCESSIVE BOTTOMING OUT AND <b>WILL VOID THE WARRANTY.</b></p>	

*Table 2*

## INSTALLATION CHECKLIST

- Clearance** — Inflate the air springs to 75-90 PSI (5.2-6.2BAR) and make sure there is at least 1/2" (13mm) clearance from anything that might rub against the air spring. This should be checked with the air spring fully inflated and fully deflated.
- Leak** — Inflate the air springs to 75-90 PSI (5.2-6.2BAR) and check all connections for leaks. All leaks must be eliminated before the vehicle is road tested.
- Heat** — Be sure there is sufficient clearance from heat sources, at least 6" (152mm) from air springs and air lines. If a heat shield was included in the kit, install it. If there is no heat shield, but one is required, call Air Lift customer service at **(800) 248-0892**.
- Fastener** — Recheck all bolts for proper torque.
- Road** — Inflate the springs to recommended driving pressures (Table 2). Drive the vehicle 10 miles (16km) and recheck for clearance, loose fasteners and air leaks.
- Operating instructions** — If professionally installed, the installer should review the operating instructions with the owner. Be sure to provide the owner with all paperwork that came with the kit.

## Maintenance and Use Guidelines

1. An Air Lift air management system is strongly recommended for this product, but it is possible to operate without one. The air lines can be routed to Schrader valves for use with a separate air compressor. Air lines and Schrader valves are not included with Air Lift Performance kits and would need to be purchased separately. To learn more Air Lift management systems visit [air-lift.co/productlines](http://air-lift.co/productlines).
2. Check the air pressure before driving.



**CAUTION**

SHOULD IT BECOME NECESSARY TO RAISE THE VEHICLE BY THE FRAME, MAKE SURE THE CONTROL SYSTEM IS TURNED OFF BEFORE LIFTING.

# Notes

---

## Limited Warranty and Return Policy

Air Lift Company provides a 1-year limited warranty to the original purchaser of Air Lift Performance damper kits from the date of original purchase, that the products will be free from defects in workmanship and materials when used on vehicles as specified by Air Lift Company and under normal operating conditions, subject to the requirements and exclusions set forth in the full Limited Warranty and Return Policy that is available online at [www.airliftperformance.com/warranty](http://www.airliftperformance.com/warranty).

For additional warranty information contact Air Lift Company customer service.



## Need Help?

Contact Air Lift Company customer service department by calling (800) 248-0892. For calls from outside the USA or Canada, dial (517) 322-2144.



Connect by searching for **Air Lift Performance** #LifeonAir



*Thank you for purchasing Air Lift Performance products!*

Air Lift Performance • 2727 Snow Road • Lansing, MI 48917 or P.O. Box 80167 • Lansing, MI 48908-0167  
Toll Free (800) 248-0892 • Local (517) 322-2144 • Fax (517) 322-0240 • [www.airliftperformance.com](http://www.airliftperformance.com)

Printed in the USA  
MB-0419

California: ⚠️WARNING: Cancer and Reproductive Harm – [www.P65Warnings.ca.gov](http://www.P65Warnings.ca.gov)

