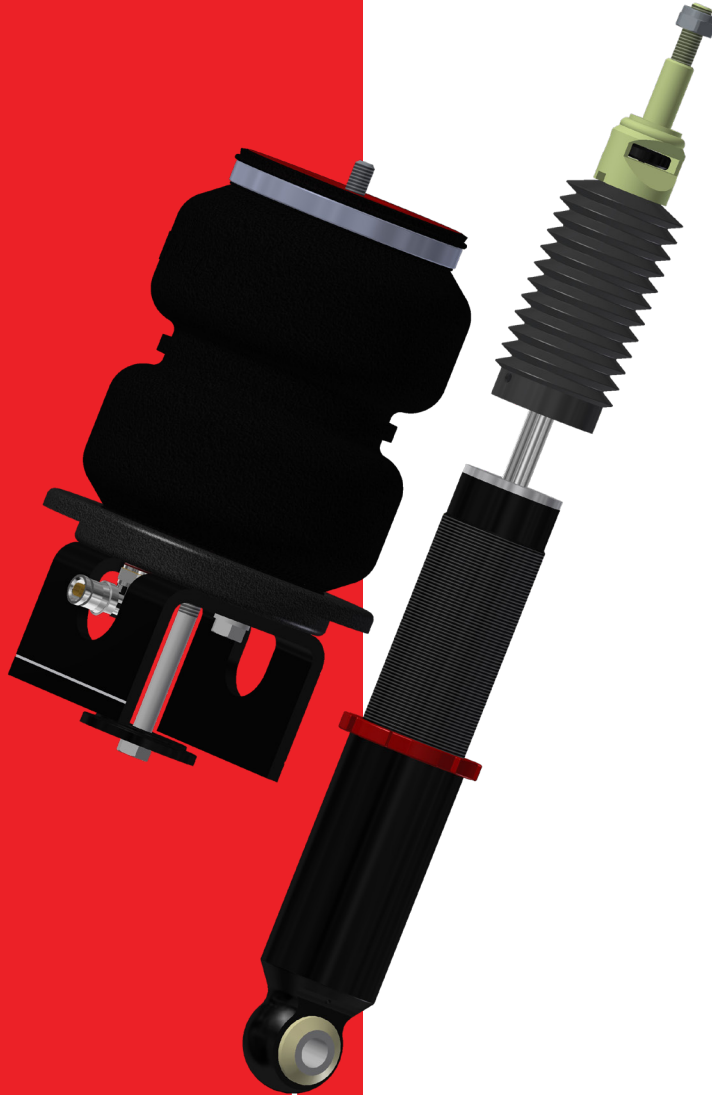


**AIR LIFT**  
**PERFORMANCE**

## Kit 75676

Volkswagen MKV & MKVI  
Platform

***Independent Rear  
Application***



## INSTALLATION GUIDE

For maximum effectiveness and safety, please read these instructions completely before proceeding with installation.

*Failure to read these instructions can result in an incorrect installation.*





## TABLE OF CONTENTS

<b>Introduction</b> .....	<b>2</b>
Notation Explanation .....	2
<b>Important Safety Notices</b> .....	<b>2</b>
<b>Installation Diagram</b> .....	<b>3</b>
Hardware List .....	3
<b>Installing the Air Suspension</b> .....	<b>4</b>
Preparing the Vehicle .....	4
Installing the Rear shock .....	4
Routing Air Lines .....	9
<b>Before Operating</b> .....	<b>9</b>
Setting the Ride Height .....	9
Torque Specifications .....	9
Suggested Driving Air Pressure and Maximum Air Pressure .....	9
Installation Checklist .....	10
Damping Adjustment .....	10
<b>Limited Warranty and Return Policy</b> .....	<b>12</b>



# Introduction

Air Lift Performance thanks you for purchasing the most complete, fully engineered high-performance air suspension made for the Volkswagen MKV & MKVI. Read these installation instructions to correctly and safely set up the vehicle for a #lifeonair.

Air Lift assumes that the installer has the mechanical knowledge and ability to work on vehicle suspension systems and has basic tools necessary to complete the project. Special tools needed to complete the installation are noted on the *Installation Diagram* page.

Air Lift reserves the right to make changes and improvements to its products and publications at any time. For the latest version of this manual, contact Air Lift Performance at **(800) 248-0892** or visit **www.airliftperformance.com**.

An Air Lift Performance air management system is highly recommended for this product. Learn more at **air-lift.co/productlines**.

## NOTATION EXPLANATION

Hazard notations appear in various locations in this publication. Information which is highlighted by one of these notations must be observed to help minimize risk of personal injury or possible improper installation which may render the vehicle unsafe. Notes are used to help emphasize areas of procedural importance and provide helpful suggestions. The following definitions explain the use of these notations as they appear throughout this guide.

** DANGER**

INDICATES IMMEDIATE HAZARDS WHICH WILL RESULT IN SEVERE PERSONAL INJURY OR DEATH.

** WARNING**

INDICATES HAZARDS OR UNSAFE PRACTICES WHICH COULD RESULT IN SEVERE PERSONAL INJURY OR DEATH.

** CAUTION**

INDICATES HAZARDS OR UNSAFE PRACTICES WHICH COULD RESULT IN DAMAGE TO THE MACHINE OR MINOR PERSONAL INJURY.

**NOTE**

*Indicates a procedure, practice or hint which is important to highlight.*

## Important Safety Notices

** WARNING**

DO NOT INFLATE AIR SPRINGS WHILE OFF OF THE VEHICLE. DAMAGE TO ASSEMBLY MAY RESULT AND VOID WARRANTY.

** CAUTION**

DO NOT WELD TO OR MODIFY PERFORMANCE STRUTS/SOCKS IN ANY WAY. DAMAGE TO UNIT MAY OCCUR AND WILL VOID WARRANTY.

# Installation Diagram

## HARDWARE LIST

Item	Part #	Description .....	Qty
A	18585	3/8"-16 Nutsert .....	2
B	18436	3/8"-16 Nut .....	2
C	17463	3/8"-16 X 2" Threaded Rod .....	2
D	17447	3/8"-16 X 1 1/4" Threaded Rod .....	2
E	58531	Air Spring 2B6 Regular (Recess Mount) .....	2
F	21779	1/4" MNPT X 1/4" PTC Elbow (DOT) .....	2
G*	21851	1/4" MNPT X 3/8" PTC 90 degree (DOT) .....	2
H	11801	Roll Plate .....	2
I	03992	Lower Bracket, MKV Rear .....	2
J	18427	3/8" Lock Washer .....	4
K	17101	3/8"-16 X 3/4" Hex Bolt .....	4
L	13980	Spring Seat Centering Spacer .....	2
M	17109	3/8"-16 X 3 1/2" Hex Cap Screw .....	2
N	17442	3/8"-16 X 3" Hex Cap Screw .....	2
O	26981	Shock, MKV/VI Rear Threaded Body .....	2

\*1/4" MNPT x 3/8" PTC fittings are NOT included in this kit, but are available as a special order.

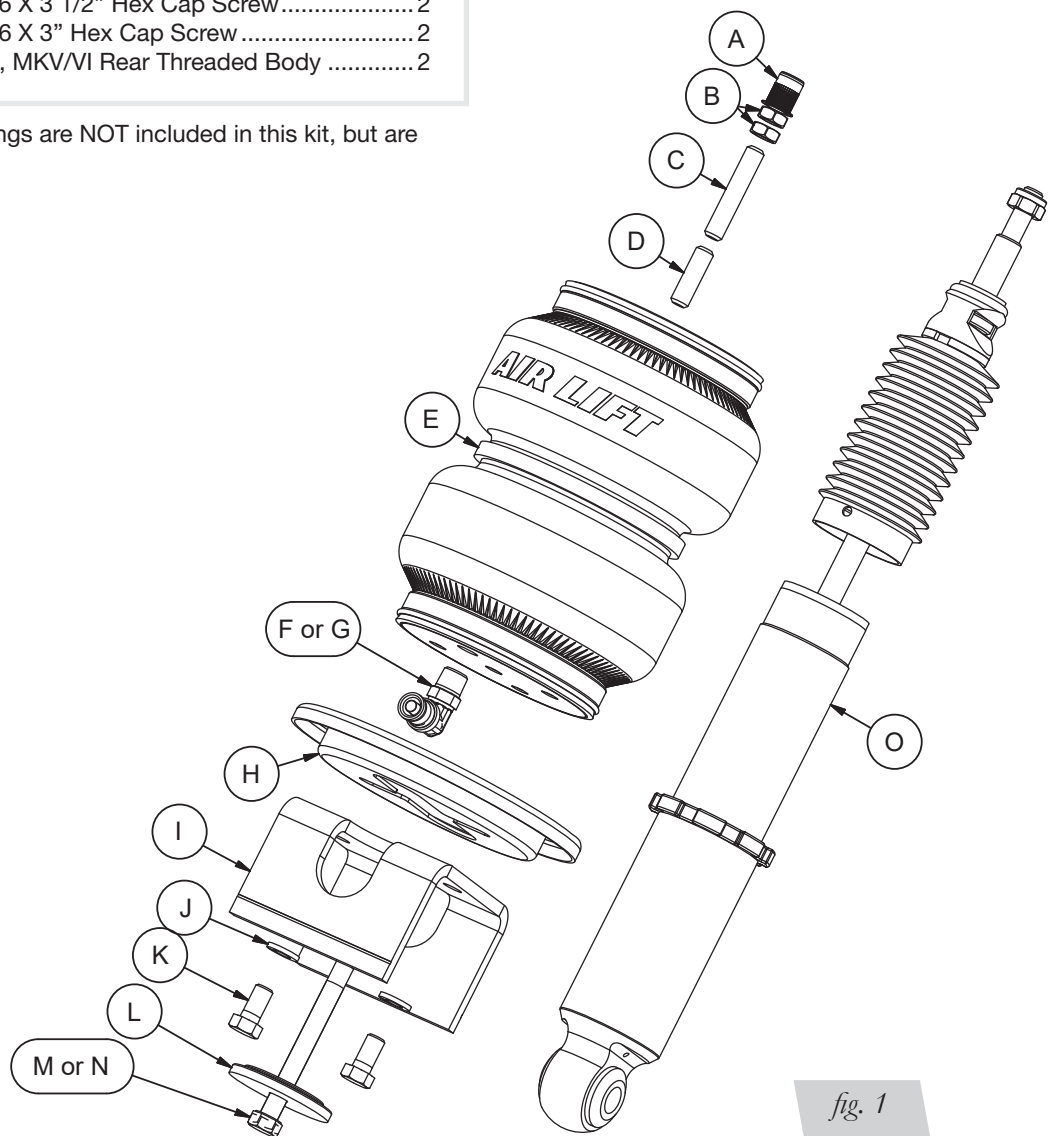


fig. 1



Missing or damaged parts? Call Air Lift customer service at (800) 248-0892 for a replacement part.

# Installing the Air Suspension

## PREPARING THE VEHICLE

1. Elevate the vehicle and support the body with a hoist or safety stands.
2. Remove the rear wheels.

### NOTE

If the vehicle is equipped with automatic vertical headlight control, disconnect the coupling rod from the lower transverse link (Fig. 2).

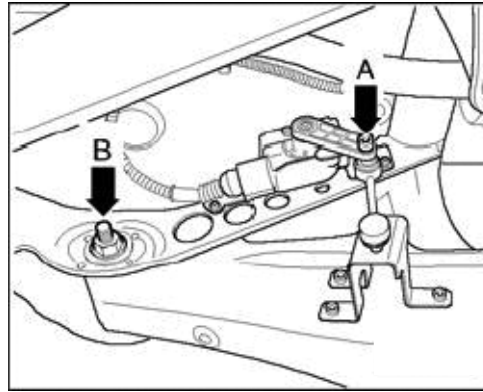


fig. 2

3. To remove the coil spring, it is recommended that you use a spring compressor.

### CAUTION

COIL SPRING UNDER COMPRESSION: THE COIL SPRING CAN BE REMOVED BY SECURELY SUPPORTING THE LOWER TRANSVERSE LINK WITH A JACK AND REMOVING THE LOWER MOUNTING BOLT FROM THE WHEEL BEARING HOUSING. SLOWLY LOWER THE TRANSVERSE LINK UNTIL THE SPRING IS LOOSE AND FREE FROM TENSION.

4. Remove the rubber isolator in the lower transverse link.
5. Disconnect the lower transverse link from the hub.
6. Support the axle carrier and remove the lower shock mount.
7. Unbolt the upper shock bracket and remove the shock from the vehicle.
8. Remove the upper bracket plastic cap and remove the nut shock rod nut. Retain the upper shock bracket and plastic cap for later use.

## INSTALLING THE REAR SHOCK

1. The rear shocks supplied in this kit are height adjustable through the use of the threaded lower mount. The shocks are threaded all the way down for maximum drop height. To adjust the height, loosen the locking collar and thread the shock cartridge in or out of the lower mount. Lock the shock cartridge in-place by torquing the collar against the lower mount 45 degrees beyond hand-tight.
  - a. Thread the out to 300mm to match the compressed height of Bilstein Sport shocks (Fig. 3).

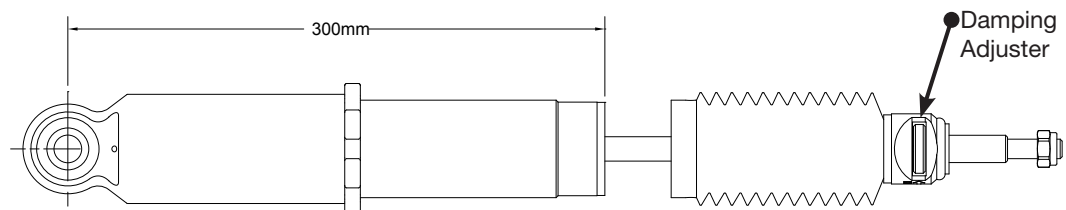


fig. 3

2. Attach the factory upper shock mount to the shock using the supplied nut and torque to 25Nm (18 lb.-ft.).
3. Reattach the shock upper bracket to the chassis and torque bolts to 50Nm + 45 degrees (37 lb.-ft. + 45 degrees).
4. Align the lower shock eye with the axle carrier and reinstall the lower shock bolt. Do not torque at this time.
5. Use a 17/32" drill bit to enlarge the hole in the upper coil spring perch. If the upper coil spring perch has been removed, drill in the center of where the perch used to be.
6. The hole must be 17/32" for the nutsert to be effective (Figs. 4-7).

Factory / OEM Upper Spring Perch



fig. 4



fig. 5

Previously Cut Spring Perch with Aftermarket Shock

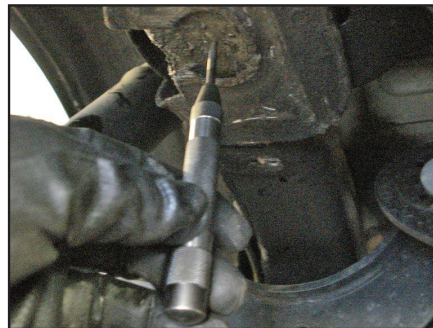


fig. 6



fig. 7

7. Assemble the nutsert and nutsert tool together and insert into the 17/32" hole. Review diagram below on how to attach the nutsert to the vehicle (Fig. 8).

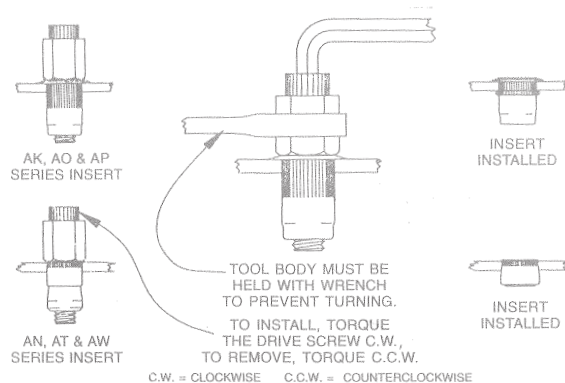
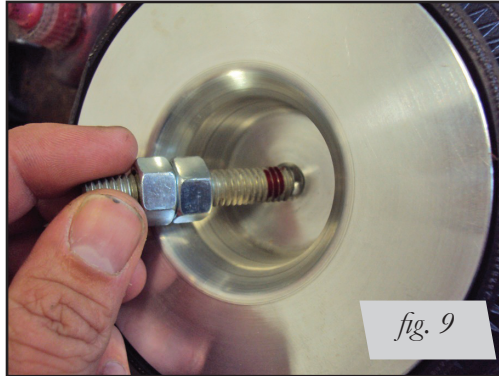


fig. 8

8. Two lengths of threaded studs are included with the kit (C or D, Fig. 1). The shorter stud is for vehicles that retain the coil spring perch bump. The longer threaded stud is for vehicles without the spring perch bump. Apply thread sealant to the threads of the upper end cap and thread in the appropriate stud. Take the supplied nuts and thread both onto one stud (Figs. 9 & 10). Using the nuts jammed together, tighten the stud into the end cap until it bottoms (Fig. 11). Remove both nuts (Fig. 12).



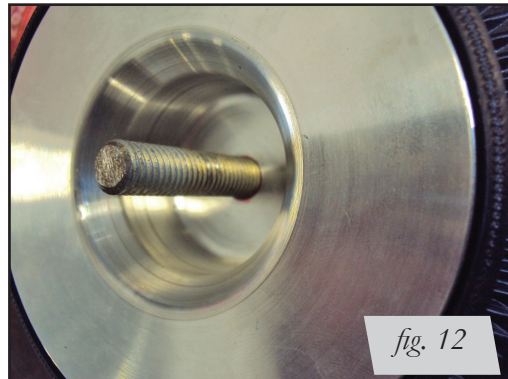
*fig. 9*



*fig. 10*



*fig. 11*



*fig. 12*

9. Cover the threads of the fitting with tape or thread sealant. Tighten the fitting 1 3/4 turns beyond hand-tight.
10. Thread the air spring into the lower end cap of the air spring. Tighten by hand (Figs. 13 & 14).

*Previously Cut Spring Perch with Aftermarket Shock*



*fig. 13*



*fig. 14*



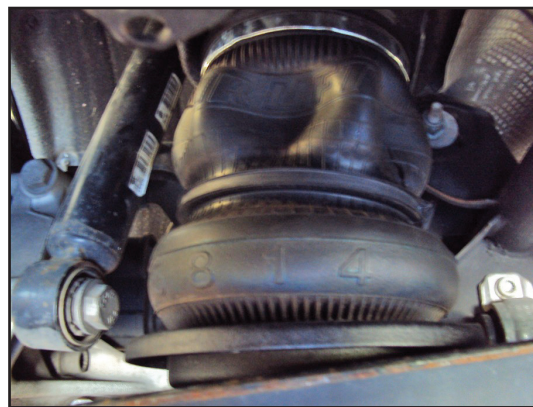
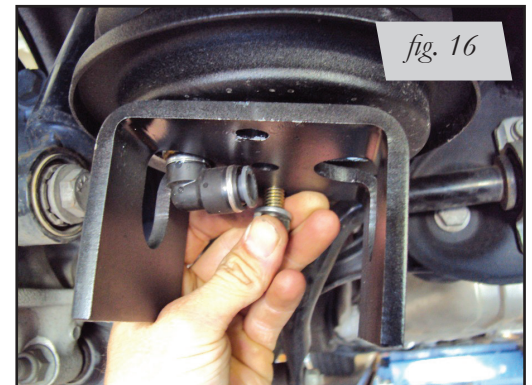
11. Orient the air fitting inline with lower transverse link toward the center of the vehicle.
12. The lower bracket in this kit has a scribe line. This indicates the height the bracket should be if using Air Lift rear shocks or shocks that allow for more drop than the factory shock absorbers with half cut jounce bumpers.

 **CAUTION**

IF RUNNING A SHORTER-THAN-FACTORY SHOCK, THE BRACKET MUST BE TRIMMED DOWN TO PREVENT THE AIR SPRING FROM BEING OVER COMPRESSED AND POTENTIALLY CAUSING A RUPTURE.

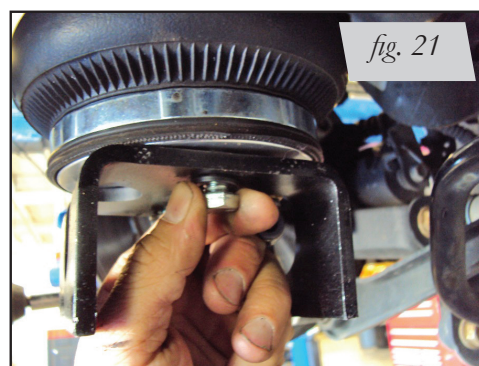
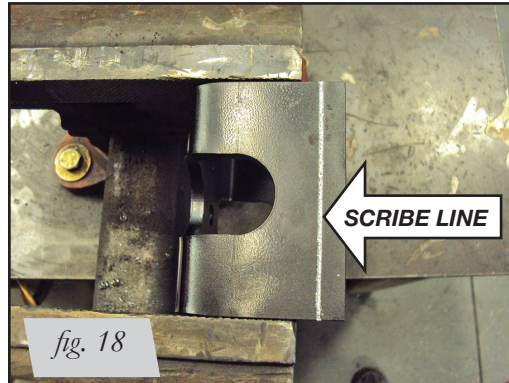
13. Attach the lower bracket and roll plate with the lock washer and bolts provided. The roll plate is used with the full length lower bracket. Roll plates are not used with a cut bracket.

*Installation with factory shock, roll plate and un-cut lower bracket (Figs. 15, 16, 17)*

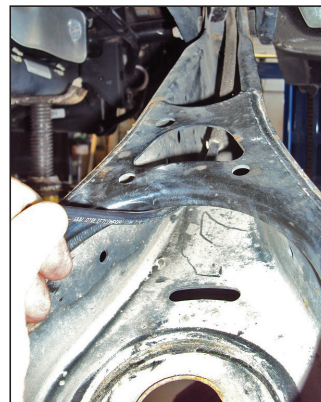


*fig. 17*

Installation with aftermarket shock, no roll plate and cut bracket (Figs. 18-21)



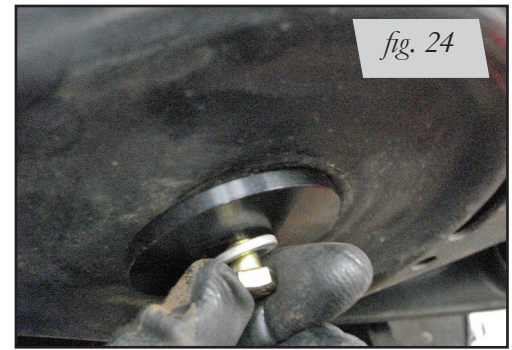
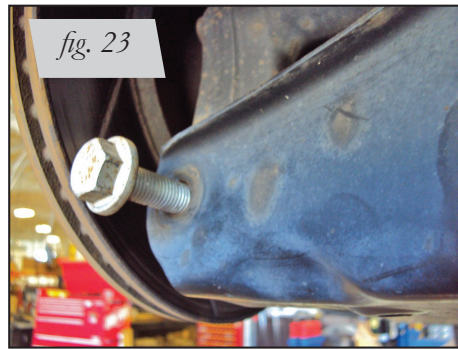
14. Route the air line from the center of the cross-member, through the lower transverse link and attach insert into the air fitting (Fig. 22).



15. Reattach the lower transverse link to the hub. Do not torque at this time (Fig. 23).

**NOTE**

*If the lower bracket has been cut, the shorter length bolt should be used to secure the assembly to the lower transverse link with the centering washer and lock washer. Uncut brackets use the longer bolt (C or D, Fig. 1) (Fig. 24).*



## ROUTING THE AIR LINES

1. Fully compress the suspension using a jack. With the suspension compressed, review the best routing for the leader line that is clear of all suspension components and axle.
2. Routing should also allow for the suspension to extend without kinking or pulling the line tight or rubbing on other components. Following the brake line routing is often a good place to start. Check clearances to all other components.

# Before Operating

## SETTING THE RIDE HEIGHT

Read the User Guide that came with this kit to set up the suspension.

Torque Specifications			
Location	TTY*	Nm	Lb.-ft.
Upper shock bracket to chassis	✓	50 + 45 degrees	37 + 45 degrees
Upper shock mount cap	✓	25	18
Wheel hub to shock eye		180	133
Lower transverse link to wheel hub	✓	90 + 90 degrees	67 + 90 degrees
Headlight alignment link		5	44 lb.-in.
Wheels		120	88

\*Torque-to-yield bolts

*Table 1*

Suggested Driving Air Pressure	Maximum Air Pressure
<b>40-70 PSI (2.8-4.8BAR)</b>	<b>125 PSI (8.6BAR)</b>
<p>FAILURE TO MAINTAIN ADEQUATE MINIMUM PRESSURE (OR PRESSURE PROPORTIONAL TO LOAD) MAY RESULT IN EXCESSIVE BOTTOMING OUT AND <b>WILL VOID THE WARRANTY.</b></p>	

*Table 2*

## INSTALLATION CHECKLIST

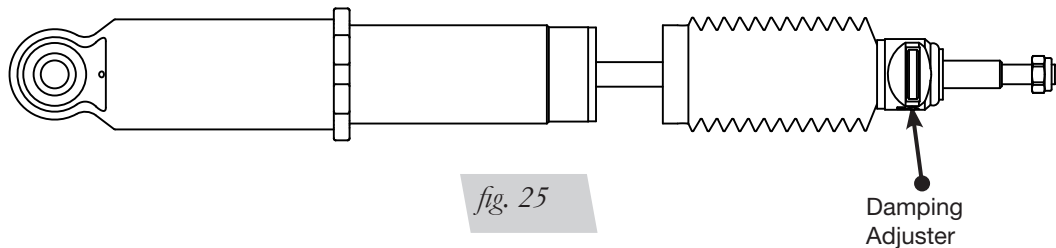
- Clearance** — Inflate the air springs to 75-90 PSI (5.2-6.2BAR) and make sure there is at least 1/2" (13mm) clearance from anything that might rub against the air spring. This should be checked with the air spring fully inflated and fully deflated.
- Leak** — Inflate the air springs to 75-90 PSI (5.2-6.2BAR) and check all connections for leaks. All leaks must be eliminated before the vehicle is road tested.
- Heat** — Be sure there is sufficient clearance from heat sources, at least 6" (152mm) from air springs and air lines. If a heat shield was included in the kit, install it. If there is no heat shield, but one is required, call Air Lift customer service at **(800) 248-0892**.
- Fastener** — Recheck all bolts for proper torque.
- Road** — Inflate the air springs to recommended driving pressures (Table 2). Drive the vehicle 10 miles (16km) and recheck for clearance, loose fasteners and air leaks.
- Operating instructions** — If professionally installed, the installer should review the operating instructions with the owner. Be sure to provide the owner with all paperwork that came with the kit.

## DAMPING ADJUSTMENT

Suspension damping is a matter of compromise. Setting it too stiff will make the ride feel jarring. In addition, if the suspension is too stiff, the tires will lose contact with the road, reducing control and power delivery. On the other hand, if the suspension is too soft, the car can experience brake dive and excessive bouncing. The sweet spot lies somewhere in the middle. Air Lift dampers have a range of adjustment, which allows the driver to tune the ride and handling to his or her preferences.

Air Lift recommends damper and air pressure settings for every vehicle kit, but it is impossible to consider every situation. For example, even though Air Lift kits replace the dampers and springs, vehicles with sport-tuned suspensions might have stiffer bushings, larger anti-roll bars, bigger wheels, wider tires, etc. These settings may need to be adjusted to different vehicles and driving characteristics.

1. The dampers in this kit have 30 settings, or "clicks," of adjustable compression and rebound damping characteristics. Damping is changed through the adjuster at the top of the shock rod (Fig. 25).
2. Turn the adjuster clockwise (H) and the damping settings are hardened, reducing oscillations and body motion. Turn the adjuster counterclockwise (S) and the damping is softened.
3. Each damper in this kit is preset to "-15 clicks." This means that the damper is adjusted 15 clicks away from full stiff, which starts at 0. Counting up from full stiff is the preferred method of keeping track of, or setting, damping. This setting was developed on a 2008 Volkswagen Jetta.



# Notes

## Limited Warranty and Return Policy

Air Lift Company provides a 1-year limited warranty to the original purchaser of Air Lift Performance damper kits from the date of original purchase, that the products will be free from defects in workmanship and materials when used on vehicles as specified by Air Lift Company and under normal operating conditions, subject to the requirements and exclusions set forth in the full Limited Warranty and Return Policy that is available online at [www.airliftperformance.com/warranty](http://www.airliftperformance.com/warranty).

For additional warranty information contact Air Lift Company customer service.

Air Lift Company reserves the right to make changes and improvements to its products and publications at any time. For the latest version of this manual, contact Air Lift Company at **(800) 248-0892** or visit [www.airliftperformance.com](http://www.airliftperformance.com).



## Need Help?

Contact Air Lift Company customer service department by calling (800) 248-0892. For calls from outside the USA or Canada, dial (517) 322-2144.



CONNECT BY SEARCHING FOR **AIR LIFT PERFORMANCE** #LIFEONAIR



*Thank you for purchasing Air Lift Performance products!*



Air Lift Performance • 2727 Snow Road • Lansing, MI 48917 or P.O. Box 80167 • Lansing, MI 48908-0167  
Toll Free (800) 248-0892 • Local (517) 322-2144 • Fax (517) 322-0240 • [www.airliftperformance.com](http://www.airliftperformance.com)

Printed in the USA  
JJC-0820

California:  WARNING: Cancer and Reproductive Harm - [www.P65Warnings.ca.gov](http://www.P65Warnings.ca.gov)