

Please read these instructions completely before proceeding with the installation.

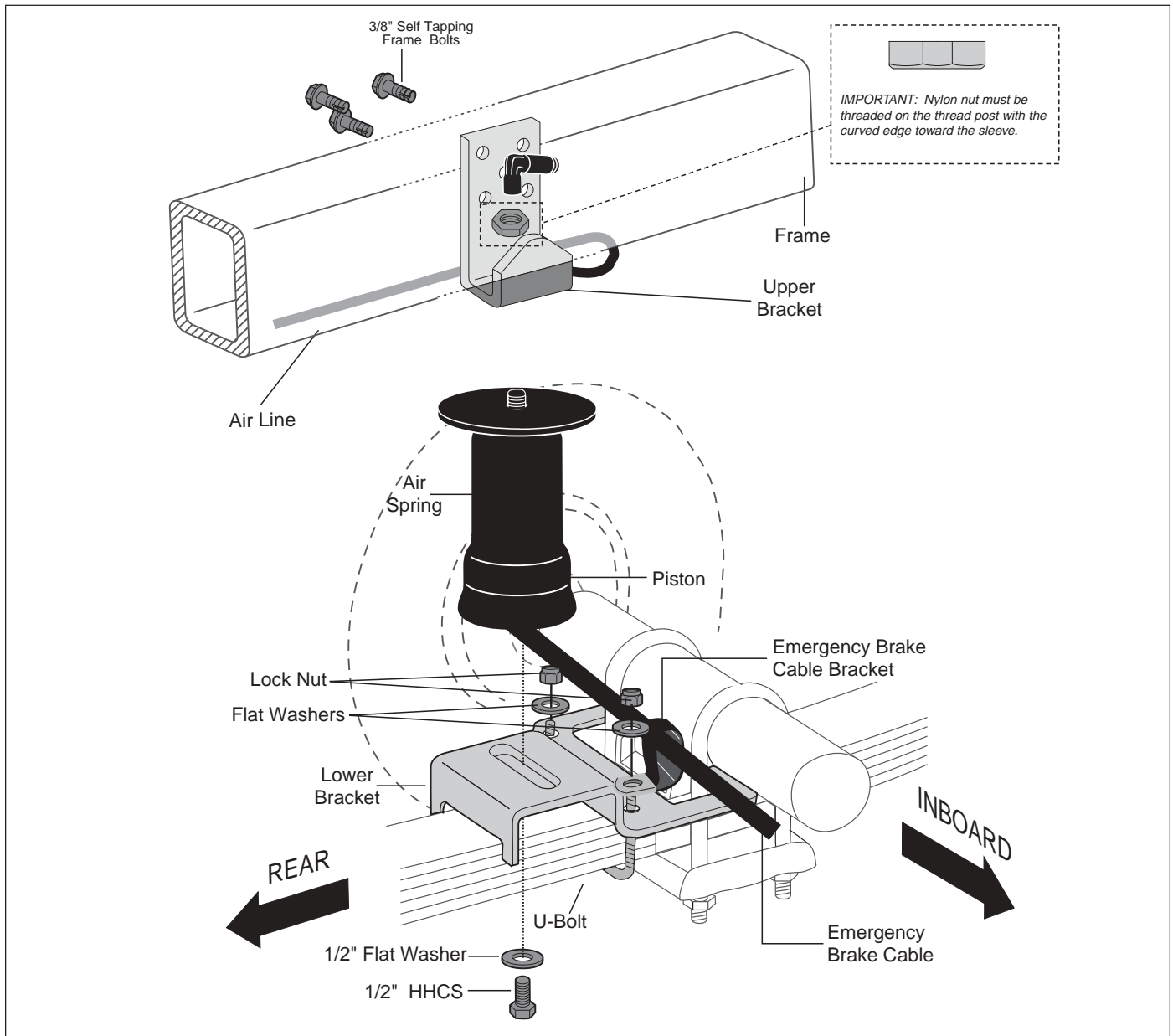

**CAUTION:** Failure to maintain correct minimum pressure (or pressure proportional to the load), bottoming out, over-extension, or rubbing against another component will void the warranty. Normal ride height, regardless of load, must always be maintained.

**CAUTION:** Do not inflate assembly when it is unrestricted. Assembly must be restricted by suspension or other adequate structure. Do not inflate beyond 100 p.s.i. Improper use or over inflation may cause assembly to burst causing property damage or severe personal injury.

**IMPORTANT:** Your vehicle may be equipped with a rear brake proportioning valve. Any type of load assist product could affect brake performance. If equipped with a brake proportioning valve, we recommend that you check with your dealer before installing this type of product. If your vehicle does not have a rear brake proportioning valve or is equipped with an anti-lock type brake system, installation of a load assist product will have no effect on brake system performance.

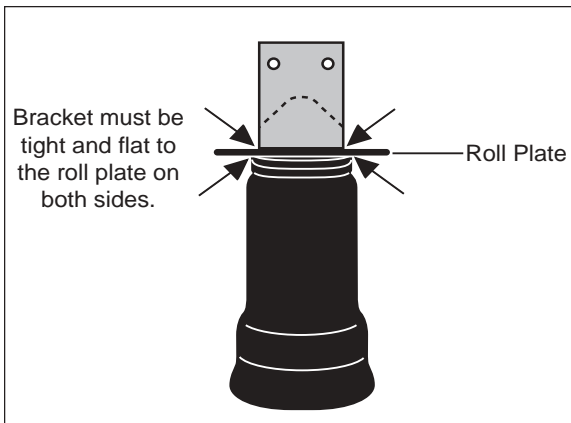

Figure 2

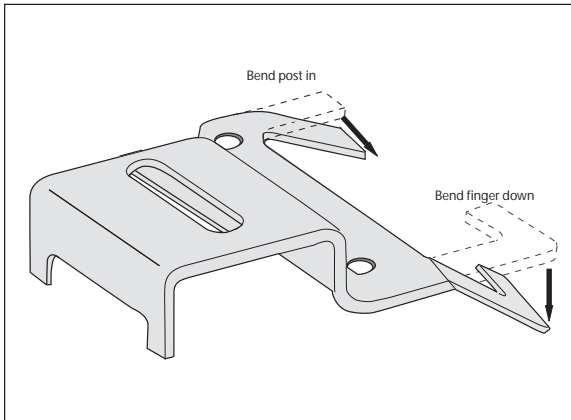

Figure 3

## I. Assembling the Kit

1. Install the swivel air fitting and tighten finger tight plus two turns into the air spring.

*NOTE: Use a 7/16" open end wrench tightening on the metal hex nut only. Do not overtighten.*

2. Insert the attached air fitting through the bottom of the J-bracket. Position the air fitting towards the rear of the vehicle for proper air line routing (Figure 1).
3. Slide the provided nylon nut over the air fitting and onto the threaded post. Make sure the curved side of the nut points toward the air spring (Figure 1).

4. Tighten the nylon nut hand-tight (4 ft/lbs) to secure the bracket.

*NOTE: The nylon nut must be threaded on the thread post with the curved edge facing toward the sleeve (Figure 1).*

5. Loosely attach the lower bracket to the bottom of the sleeve using a 1/2" bolt and 1/2" flat washer (Figure 1).

## II. Installing Assemblies onto the Leaf Spring

1. Jack up the rear of the vehicle or raise on a hoist and remove the tires.
2. Raise or lower the frame to its original ride height when in an unloaded condition.
3. Set the assembly onto the leaf spring behind the axle. Butt the bracket against the spring perch. Make sure the "hook" or "finger" of the bracket is forward of the U-bolt (Figure 1).
4. Install the emergency brake cable clamp onto the emergency brake cable as shown in Figure 1. Secure the lower bracket to the leaf springs by using the provided U-bolts, flat washers, and locknuts.

*NOTE: The emergency brake cable clamps will attach to the inside post of the U-bolt (Figure 1).*

Torque to 16 ft/lbs.

*NOTE: On most models, the "hook" or "finger" may not hook around the U-bolt. In this case, bend the post of the U-bolt into the spring and bend the finger down so it locks around the U-bolt (Figure 3). This will prevent the lower bracket from moving on the leaf spring.*

### III. Installing the Upper Bracket

1. On the driver-side, you will have to remove a plastic plug (Figure 4) from the frame in order to attach the upper bracket.
2. To install the upper bracket, the upper bracket must be in line with the lower bracket and on the same angle as the leaf spring. The upper bracket must be parallel and perpendicular to the lower bracket (Figure 5). The upper bracket is designed so that it can be "tilted" for the proper angle (Figure 6). The bottom of the upper bracket must fit tight to the bottom of the frame rail (Figure 7).

2. Mount the bracket to the frame using at least three of the five pre-drilled mounting holes on the upper bracket. Any combination of three is permissible.

- a. Use the bracket as a template to centerpunch and drill three  $\frac{5}{16}$ " holes. The holes must be no larger than  $\frac{5}{16}$ ".

*CAUTION: Do not drill holes into the frame until any and all hydraulic, fuel, or electrical lines in the area to be drilled have been moved or shielded.*

- b. Attach the upper bracket using the self-tapping frame bolts and tighten to 15 ft/lbs (Figure 1). Do not over tighten.

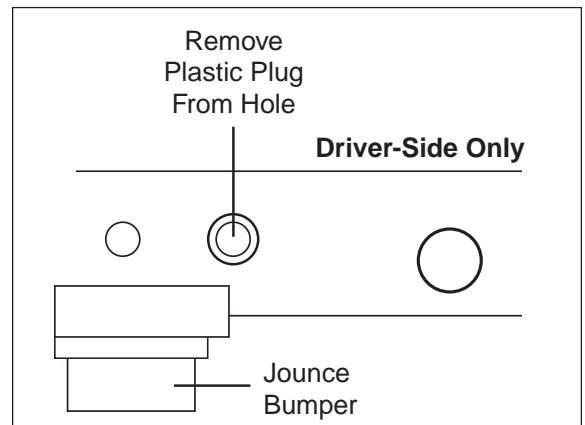

Figure 4

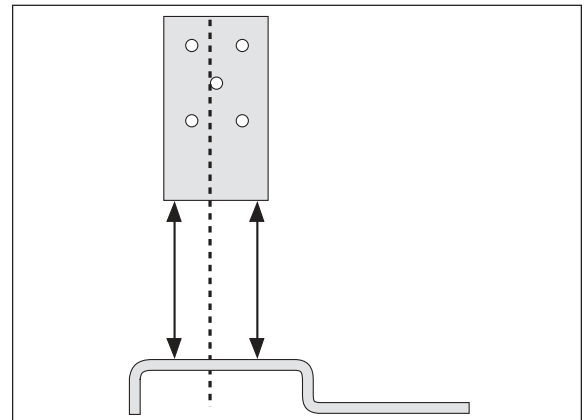

Figure 5

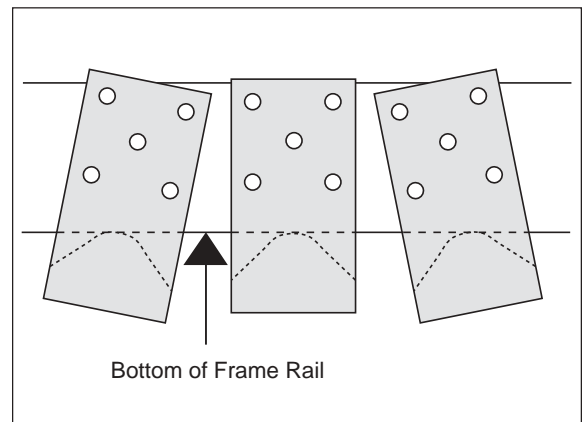

Figure 6

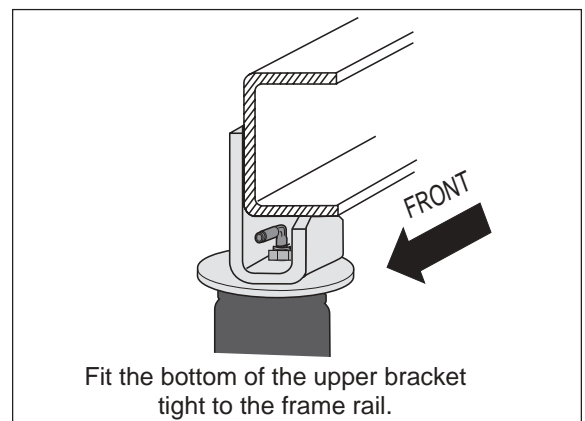

Figure 7

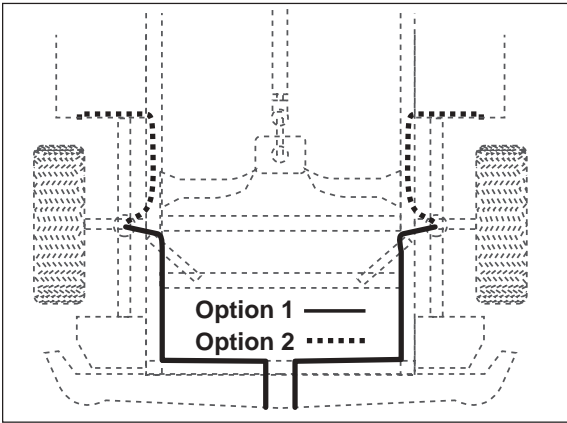

Figure 8

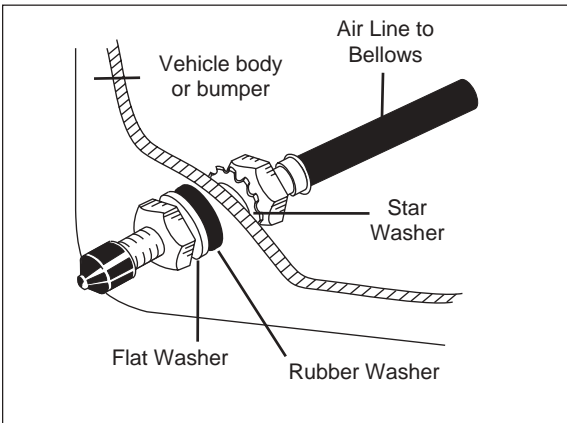

Figure 9

#### IV. Installing the Air Lines

1. Select a location for the inflation valves in the rear bumper area or rocker panel flange ensuring that each valve will be protected and accessible with an air hose (Figure 8).
  - a. Drill  $\frac{5}{16}$ " hole for inflation valve and mount as illustrated.
  - b. Install the rubber washer on the outside. It is for weather seal (Figure 9).

2. Route air line along frame from inflation valve location to the air fitting (Figure 8). Attach air line to chassis with the provided plastic straps.

*CAUTION: To prevent the air line from melting, keep it at least 12" from the exhaust system.*

3. Use a standard tube cutter, a razor blade, or very sharp knife to cut the air line. A clean square cut will ensure against leaks. Cut off excess air line squarely.
4. Install the air line into the fitting. Push and slightly turn the cut end of the air line into the fitting as far as it will go (approximately  $\frac{9}{16}$ "). A definite "click" can be heard and/or felt when the air line is seated. The air line is now installed.
5. Repeat steps II-IV for the other side.

#### V. Finishing the Installation

1. **VERY IMPORTANT:** With the bottom of the air spring still loose, inflate the air spring to approximately 10 p.s.i. By using the slot in the lower bracket for adjustment, center the sleeve so that it is in line with the upper and lower bracket and that there is a symmetrical cushion of air around the lower base of the sleeve to prevent side load wear (Figure 10). This can be accomplished by pressing all around the air spring and tapping it inboard or outboard for proper alignment. Air spring diameter grows to 5.1" at maximum inflation. Check to be sure there is clearance all around the air spring when fully inflated.
2. Tighten the lower mounting bolt to 10 ft/lbs. Do not over tighten.
3. Inflate to 30 p.s.i. Check all fittings and valve core for leaks with a liquid solution of  $\frac{1}{5}$  dish soap to  $\frac{4}{5}$  water mixed in a spray bottle. Recheck air pressure after 24 hours. A 2–4 p.s.i. loss after initial installation is normal. If pressure has dropped more than 5 lbs retest for leaks with soapy water solution. Please read and follow the Maintenance and Operations sections.

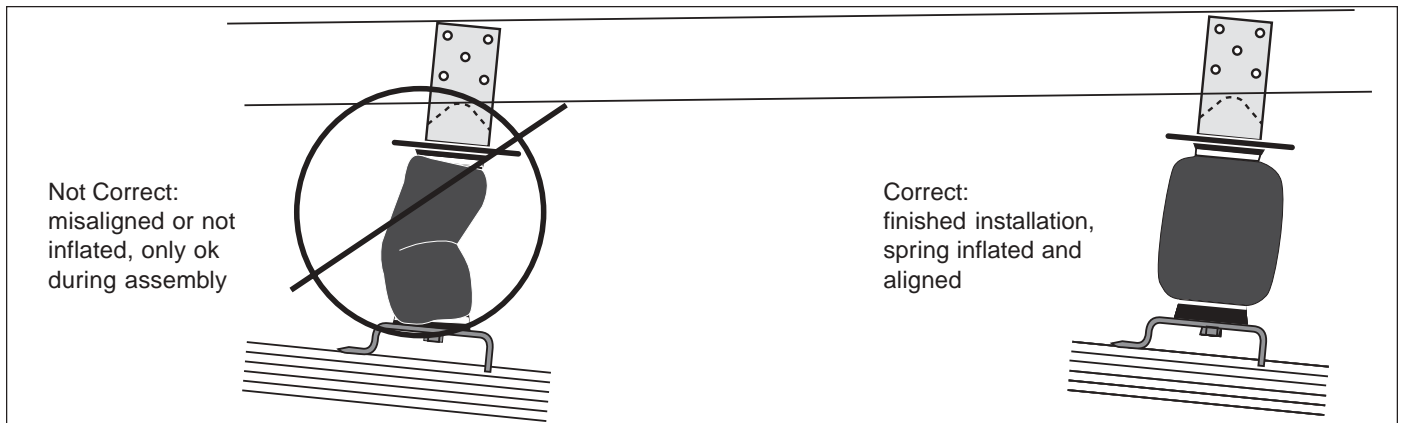

Figure 10

MINIMUM AIR PRESSURE	MAXIMUM AIR PRESSURE
10 p.s.i.	100 p.s.i.
<p><i>Failure to maintain correct minimum pressure (or pressure proportional to load), bottoming out, over-extension, or rubbing against another component will void the warranty.</i></p> <p><i>Regardless of load, the air pressure must always be adjusted so that the normal ride height is maintained at all times.</i></p>	

### Maintenance of the System

1. Check pressure weekly.
2. Always maintain at least 10 p.s.i. air pressure.
3. If you develop an air leak in the system, use a soapy water solution to check all air line connections and the inflation valve core before removing sleeve.

### Operation of the System

1. Inflate your air springs to 60 p.s.i. before adding the payload. After vehicle is loaded, adjust your air pressure to level the vehicle.
2. **IMPORTANT:** For your safety and to prevent possible damage to your vehicle, do not exceed maximum load recommended by the vehicle manufacturer. Although your air springs are rated at maximum inflation pressure of 100 p.s.i., the air pressure actually needed is dependant on the load and Gross Vehicle Weight Rating (GVWR), which may be less than 100 p.s.i. Check your vehicle owner's manual and do not exceed maximum loads listed for your vehicle.
3. When inflating your Air Lift sleeves, add pressure in small quantities, check the pressure frequently during inflation. The sleeves require much less air volume than a tire and therefore inflate much faster.
4. Should it become necessary to raise the vehicle by the frame, make sure the system is at minimum pressure (10 p.s.i.) to reduce the tension on suspension/brake components. Check to see that the air spring rolls back down over the bottom piston after the vehicle is lowered. If sleeve fails to roll back down over the piston, add air pressure until sleeve "pops" back over piston (do not exceed 100 p.s.i.).



***Thank you for purchasing Air Lift Products***

Mailing Address:  
AIR LIFT COMPANY  
P.O. Box 80167  
Lansing, MI 48908-0167

Street Address:  
AIR LIFT COMPANY  
2727 Snow Rd.  
Lansing, MI 48917

Local Phone: (517) 322-2144  
Fax: (517) 322-0240

For Technical Assistance call 1-800-248-0892

***“The Choice of the Professional Installer”***

Printed in the USA



# Product Use Information

## Frequently asked questions

**Q. Will installing air springs increase the weight ratings of a vehicle?**

No. Adding air springs will not change the weight ratings (GAWR, GCWR and/or GVWR) of a vehicle. Exceeding the GVWR is dangerous and voids the Air Lift warranty.

**Q. Is it necessary to keep air in the air springs at all time and how much pressure will they need?**

The minimum air pressure should be maintained at all times. The minimum air pressure keeps the air spring in shape, ensuring that it will move throughout its travel without rubbing or wearing on itself.

**Q. Is it necessary to add a compressor system to the air springs?**

No. Air pressure can be adjusted with any type of compressor as long as it can produce sufficient pressure to service the springs. Even a bicycle tire pump can be used, but it's a lot of work.

**Q. How long should air springs last?**

If the air springs are properly installed and maintained they can last indefinitely.

**Q. Will raising the vehicle on a hoist for service work damage the air springs?**

No. The vehicle can be lifted on a hoist for short-term service work such as tire rotation or oil changes. However, if the vehicle will be on the hoist for a prolonged period of time, support the axle with jack stands in order to take the tension off of the air springs.

## Tuning the air pressure

Pressure determination comes down to three things — level vehicle, ride comfort, and stability.

**1. Level vehicle**

If the vehicle's headlights are shining into the trees or the vehicle is leaning to one side, then it is not level (fig. 1). Raise the air pressure to correct either of these problems and level the vehicle.

**2. Ride comfort**

If the vehicle has a rough and harsh ride it may be due to either too much pressure or not enough (fig. 2). Try different pressures to determine the best ride comfort.

**3. Stability**

Stability translates into safety and should be the priority, meaning the driver may need to sacrifice a perfectly level and comfortable ride. Stability issues include roll control, bounce, dive during braking and sponginess (fig. 3). Tuning out these problems usually requires an increase in pressure.

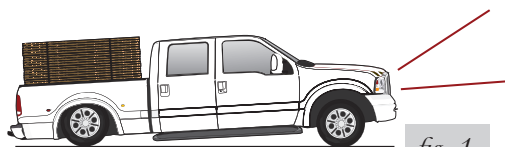

Bad headlight aim



Sway and body roll



Rough ride

### Guidelines for adding air:

1. Start with the vehicle level or slightly above.
2. When in doubt, always add air.
3. For motorhomes, start with 50-100 PSI in the rear because it can be safely assumed that it is heavily loaded.
4. If the front of the vehicle dives while braking, increase the pressure in the front air bags, if equipped.
5. If it is ever suspected that the air bags have bottomed out, increase the pressure (fig. 4).
6. Adjust the pressure up and down to find the best ride.
7. If the vehicle rocks and rolls, adjust the air pressure to reduce movement.
8. It may be necessary to maintain different pressures on each side of the vehicle. Loads such as water, fuel, and appliances will cause the vehicle to be heavier on one side (fig. 5). As much as a 50 PSI difference is not uncommon.

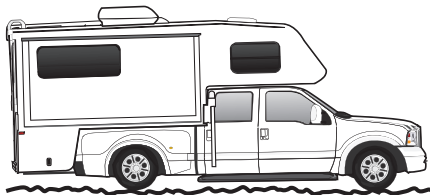

Bottoming out

fig. 4

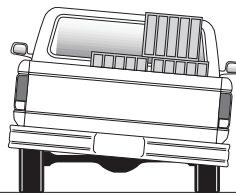

Unlevel

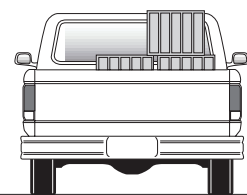

Level

fig. 5

## Warranty and Returns Policy

Air Lift Company warrants its products, for the time periods listed below, to the original retail purchaser against manufacturing defects when used on catalog-listed applications on cars, vans, light trucks and motorhomes under normal operating conditions for as long as Air Lift manufactures the product. The warranty does not apply to products that have been improperly applied, improperly installed, used in racing or off-road applications, used for commercial purposes, or which have not been maintained in accordance with installation instructions furnished with all products. The consumer will be responsible for removing (labor charges) the defective product from the vehicle and returning it, transportation costs prepaid, to the dealer from which it was purchased or to Air Lift Company for verification.

Air Lift will repair or replace, at its option, defective products or components. A minimum \$10.00 shipping and handling charge will apply to all warranty claims. Before returning any defective product, you must call Air Lift at (800) 248-0892 in the U.S. and Canada (elsewhere, (517) 322-2144) for a Returned Materials Authorization (RMA) number. Returns to Air Lift can be sent to: Air Lift Company • 2727 Snow Road • Lansing, MI • 48917.

Product failures resulting from abnormal use or misuse are excluded from this warranty. The loss of use of the product, loss of time, inconvenience, commercial loss or consequential damages is not covered. The consumer is responsible for installation/reinstallation (labor charges) of the product. Air Lift Company reserves the right to change the design of any product without assuming any obligation to modify any product previously manufactured.

This warranty gives you specific legal rights and you may also have other rights that vary from state-to-state. Some states do not allow limitations on how long an implied warranty lasts or allow the exclusion or limitation of incidental or consequential damages. The above limitation or exclusion may not apply to you. There are no warranties, expressed or implied including any implied warranties of merchantability and fitness, which extend beyond this warranty period. There are no warranties that extend beyond the description on the face hereof. Seller disclaims the implied warranty of merchantability. (Dated proof of purchase required.)

**Air Lift 1000** ..... **Lifetime Limited**  
**RideControl** ..... **Lifetime Limited**  
**SlamAir** ..... **Lifetime Limited**  
**LoadLifter 5000\*** ..... **Lifetime Limited**  
**EasyStreet Systems** ..... **1 Year Limited**

**Load Controller (I)** ..... **2 Year Limited**  
**Load Controller (II)** ..... **2 Year Limited**  
**SmartAir** ..... **2 Year Limited**  
**Wireless AIR**..... **2 Year Limited**  
**Other Accessories**..... **2 Year Limited**

*\*formerly SuperDuty*