

advanced FLOW engineering

Track Series Cold Air Intake System

Instruction Manual P/N: 57-10016D / 57-10016R

Make: Volkswagen	Model: GTI	Year: 2015-2021	Engine: L4-2.0L (t)
Make: Volkswagen	Model: Golf R	Year: 2015-2019	Engine: L4-2.0L (t)
Make: Volkswagen	Model: Jetta GLI	Year: 2019-2021	Engine: L4-2.0L (t)
Make: Audi	Model: A3	Year: 2015-2020	Engine: L4-2.0L (t)
Make: Audi	Model: S3	Year: 2015-2020	Engine: L4-2.0L (t)



- Please read the entire instruction manual before proceeding.
- Ensure all components listed are present.
- For technical support please call 951-493-7185.
- Ensure you have all necessary tools before proceeding.
- Do not attempt to work on your vehicle when the engine is hot.
- Retain factory parts for future use.

Label	Qty.	Description	Part Number
A1	1	Air Filter (Pro 5R)	24-91155
A2	1	Air Filter (Pro DRY S)	21-91155
B	1	Housing	05-5710016B2
C	1	Carbon Fiber Tube	05-5710016C1
D	1	Seal, Trim: Double Bulb (35"L)	05-01534
E	1	Coupling, Silicone Reducer	05-01196
F	1	Inlet Trim, Silicone	05-01657
G	1	Clamp, #044	03-50019
H	1	Clamp, #048	03-50007
I	3	Grommet, Silicone	03-50647
J	1	Smog Pump Cap, Vinyl	03-50747

Installation will require the following tools:

7mm & 8mm nut drivers, trim removal tool

Warranty Information available at <https://afepower.com/contact#warranty>

Emissions Disclaimer: This product is not currently CARB exempt and is not available for purchase in California or for use on any vehicle registered with the California Department of Motor Vehicles.

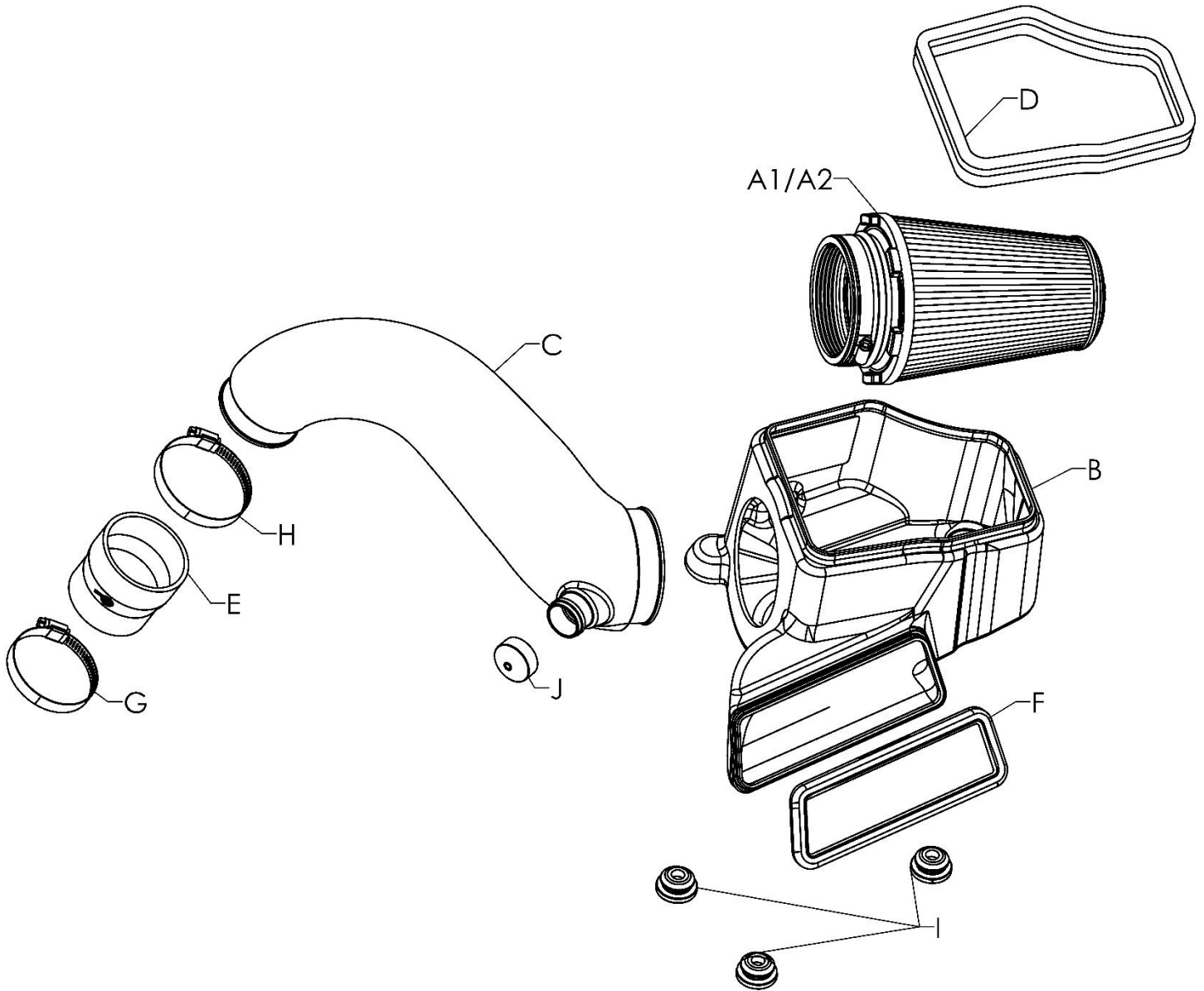

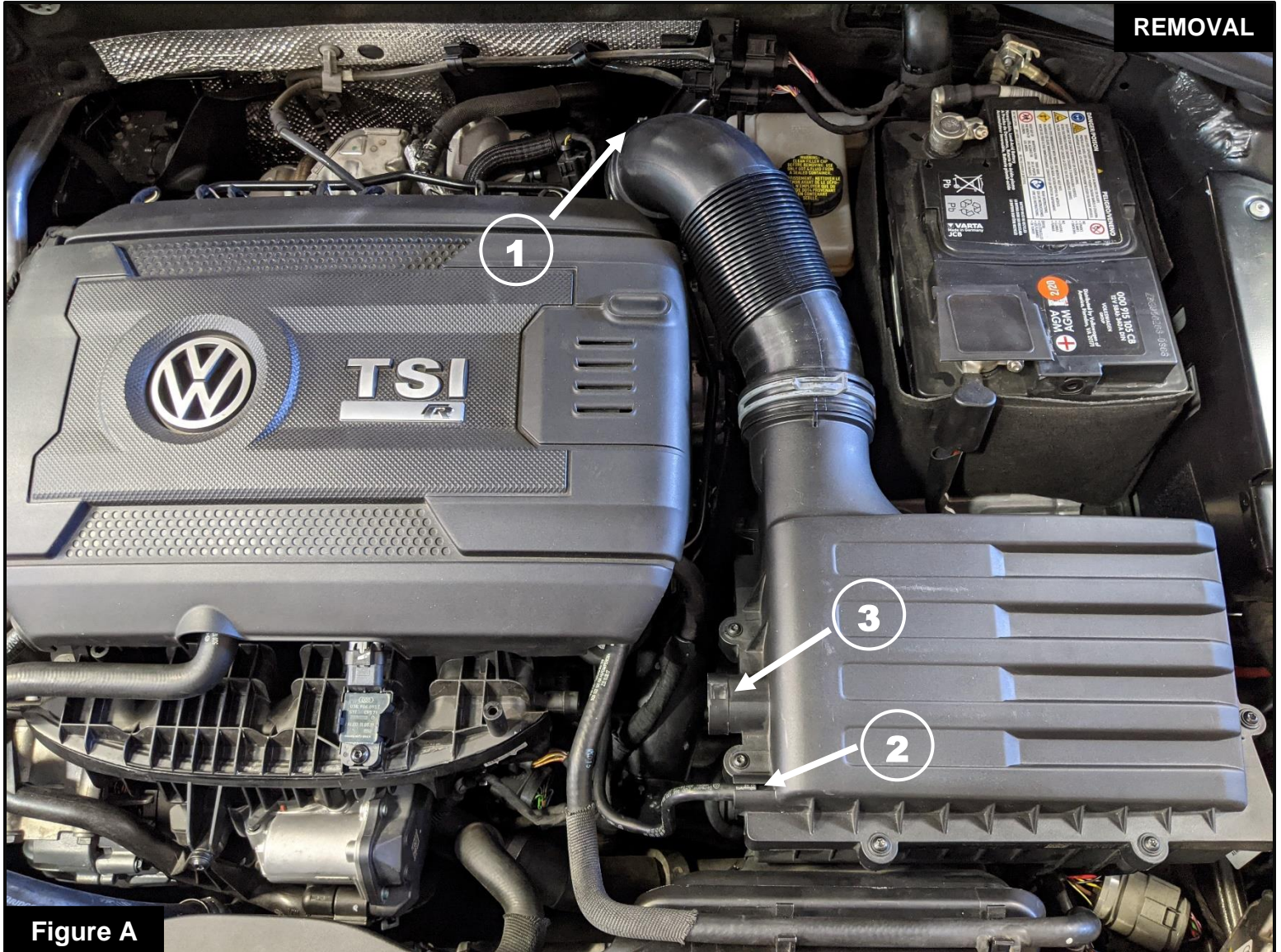

Figure A

Refer to Figure A for Steps 1-4

Step 1: Using a 7mm nut driver, loosen the clamp ① at the factory turbo inlet.

Step 2: Disconnect the CCV line ② from the side of the factory filter housing.

Step 3: If your vehicle is equipped with a smog pump, disconnect the smog pump fitting ③ from the factory filter housing.

Step 4: Remove the factory filter housing and intake tube by pulling straight up off the mounting grommets.



Refer to Figure B for Steps 5-6

Step 5: Install the supplied reducer coupling and #044 clamp with the smaller side on your turbo inlet and tighten using an 8mm nut driver.

Step 6: Place the #048 clamp loosely around the open end of the coupler.



Figure C

Refer to Figure C for Step 7

Step 7: Install the 3 supplied silicone grommets ④ into the bottom of your aFe POWER intake housing.



Figure D

Refer to Figure D for Step 8

Step 8: Install the supplied silicone inlet trim (5) onto the inlet of your aFe POWER housing.



Figure E

Refer to Figure E for Step 9

Step 9: Install the supplied length of trim seal along the top opening of your aFe POWER housing as shown.

If necessary, trim to fit.



Figure F

Refer to Figure F for Step 10

Step 10: Install your aFe POWER intake housing into the vehicle by sliding the front inlet onto the OE scoop, then rotating the housing down onto the mounting points.

**Figure G****Refer to Figure G for Step 11**

Step 11: Remove the filter clamp ⑥ from the aFe POWER air filter. Slide the filter into your aFe POWER housing from the top, then guide the filter flange through the round opening in the housing, snapping the filter into place. Place the clamp back on the filter flange.

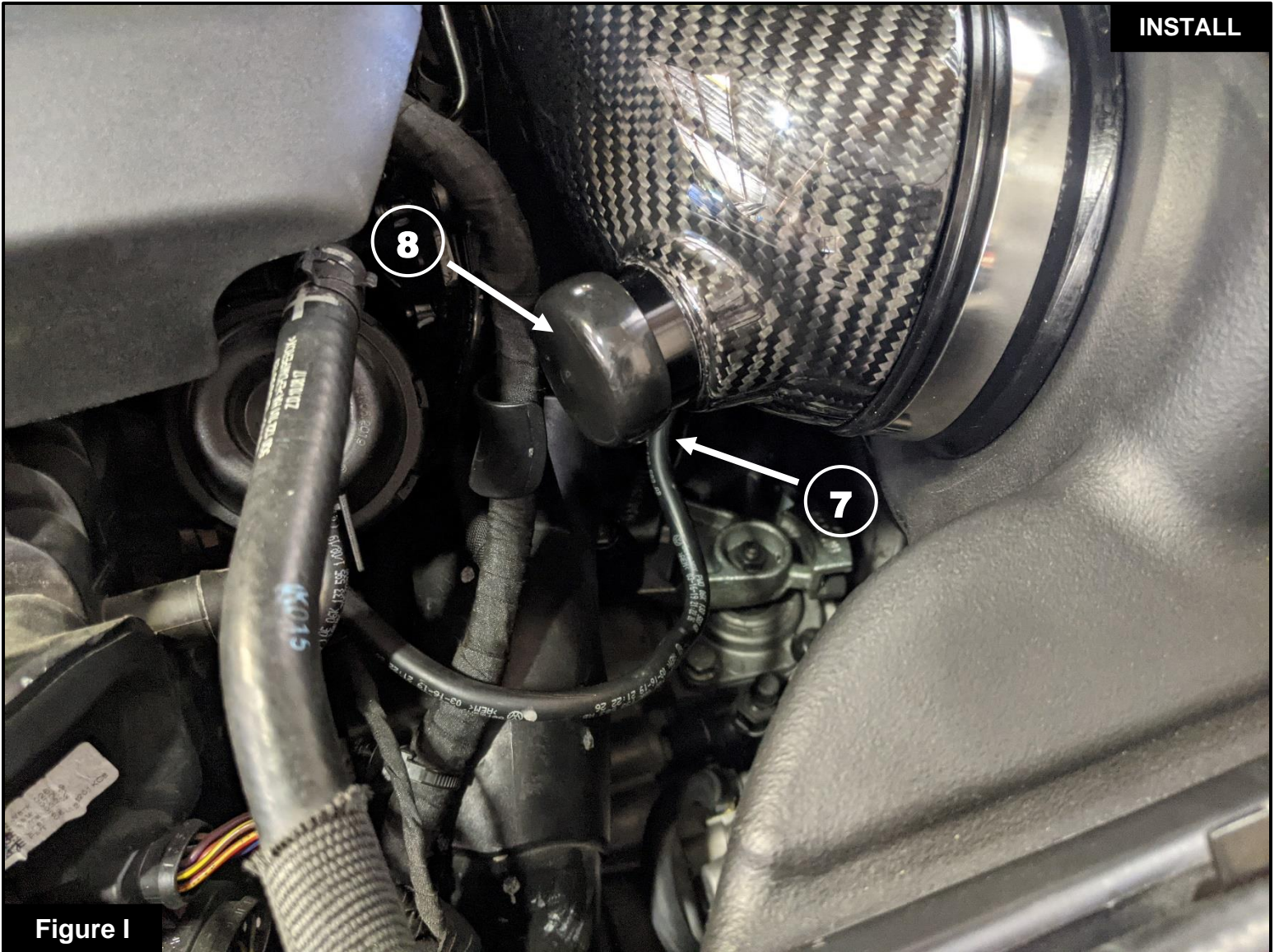

Figure H

Refer to Figure H for Steps 12-13

Step 12: Install your aFe POWER carbon fiber intake tube by first inserting the larger end into the air filter, then rotating the smaller end down into the coupling on the turbo inlet. Using a trim removal tool between the carbon tube and the coupling on the turbo inlet may be necessary.

Step 13: Tighten all clamps using an 8mm nut driver.

**Figure I****Refer to Figure I for Steps 14-15**

- Step 14: Reconnect your CCV line (7) to the fitting on the bottom side of your carbon fiber intake tube.
- Step 15: If your vehicle is equipped with a smog pump, reconnect the smog pump hose to the fitting on the side of your carbon fiber intake tube. If your vehicle is not equipped with a smog pump, place the supplied vinyl cap (8) onto the fitting on your carbon fiber intake tube.



Refer to Figure J for Step 16

Step 16: Confirm that all connections are secure and clamps tightened. Your installation is now complete.

Thank you for choosing aFe POWER!

NOTE: Check all clamps, and connectors are secure after 100-200 miles



PAGE LEFT BLANK INTENTIONALLY



PAGE LEFT BLANK INTENTIONALLY



advanced FLOW engineering, inc.

252 Granite Street Corona, CA 92879
TEL: 951.493.7100 • TECH: 951.493.7185
E-Mail: Tech@aFepower.com