

**advanced FLOW engineering** Takeda Momentum Cold Air Intake System

**Instruction Manual** P/N: 56-70050D / 56-70050R

Make: Toyota  
Make: BMW

Model: Supra (A90)  
Model: Z4 M40i (G29)

Year: 2021-2023  
Year: 2020-2023

Engine: L6-3.0L (t) B58  
Engine: L6-3.0L (t) B58



- Please read the entire instruction manual before proceeding.
- Ensure all components listed are present.
- For technical support please call at 951-493-7185.
- Ensure you have all necessary tools before proceeding.
- Do not attempt to work on your vehicle when the engine is hot.
- Retain factory parts for future use.

Label	Qty.	Description	Part Number
A1	1	Air Filter (Pro DRY S)	21-91113
A2	1	Air Filter (Pro 5R)	24-91113
B	1	Tube	05-5670015B1
C	1	Housing	05-5670037B2
D	1	Coupling, Silicone Bellow: 3.1"ID x 3"L	05-01525
E	2	Clamp, #048	03-50007
F	1	Fitting, Aluminum	03-50644
G	2	Screw, M4	03-50490

**Installation will require the following tools:**

6mm and 8mm nut drivers or sockets, socket wrench, flat-head screwdriver, T20 torx bit, and panel popper.

Warranty information available at <https://afepower.com/contact#warranty>.

**Emissions Disclaimer:**

This product is not currently CARB exempt and is not available for purchase in California or for use on any vehicle registered with the California Department of Motor Vehicles.

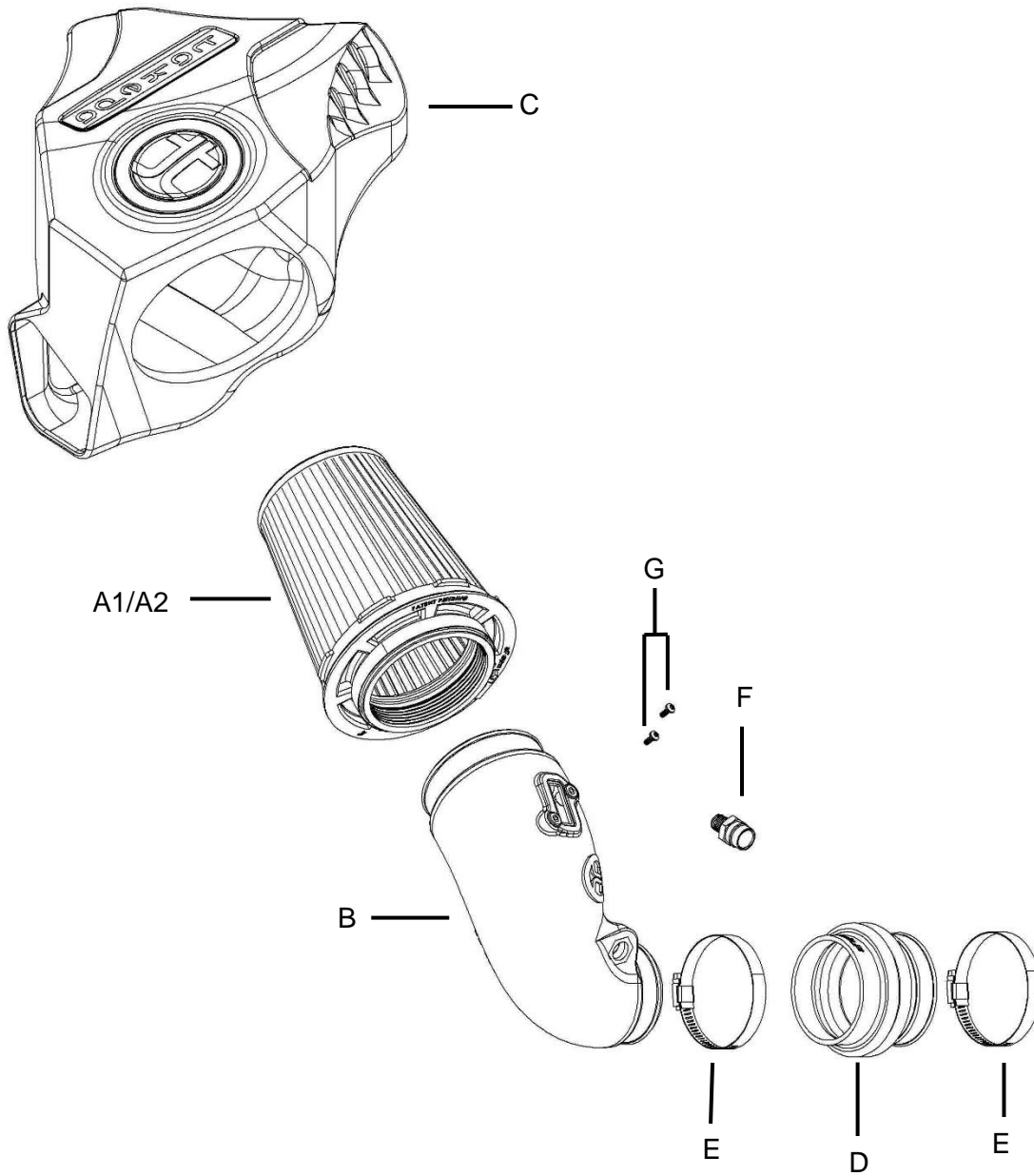



**Refer to Figure A for Steps 1-4**

Step 1: If the vehicle is equipped with a brace above the factory intake, remove the brace.

Step 2: Disconnect the temperature sensor harness.

Step 3: Using a 6mm nut driver, loosen the hose clamp at the factory airbox. Then, slide the factory intake tube away from the factory airbox.

Step 4: To remove the factory airbox, carefully pull up on the factory airbox.

REMOVAL

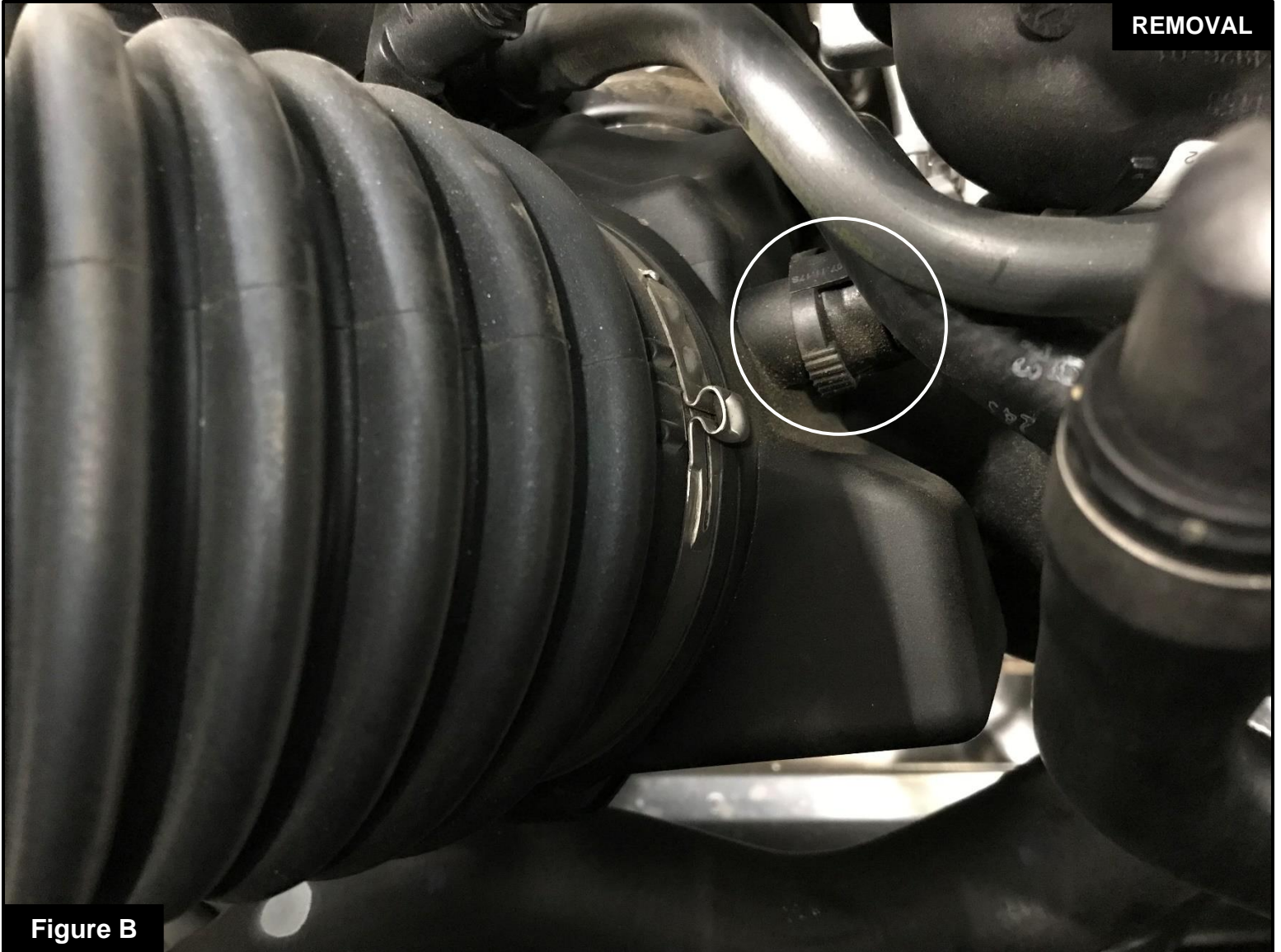

Figure B

**Refer to Figure B for Step 5**

Step 5: Disconnect the crankcase breather line.

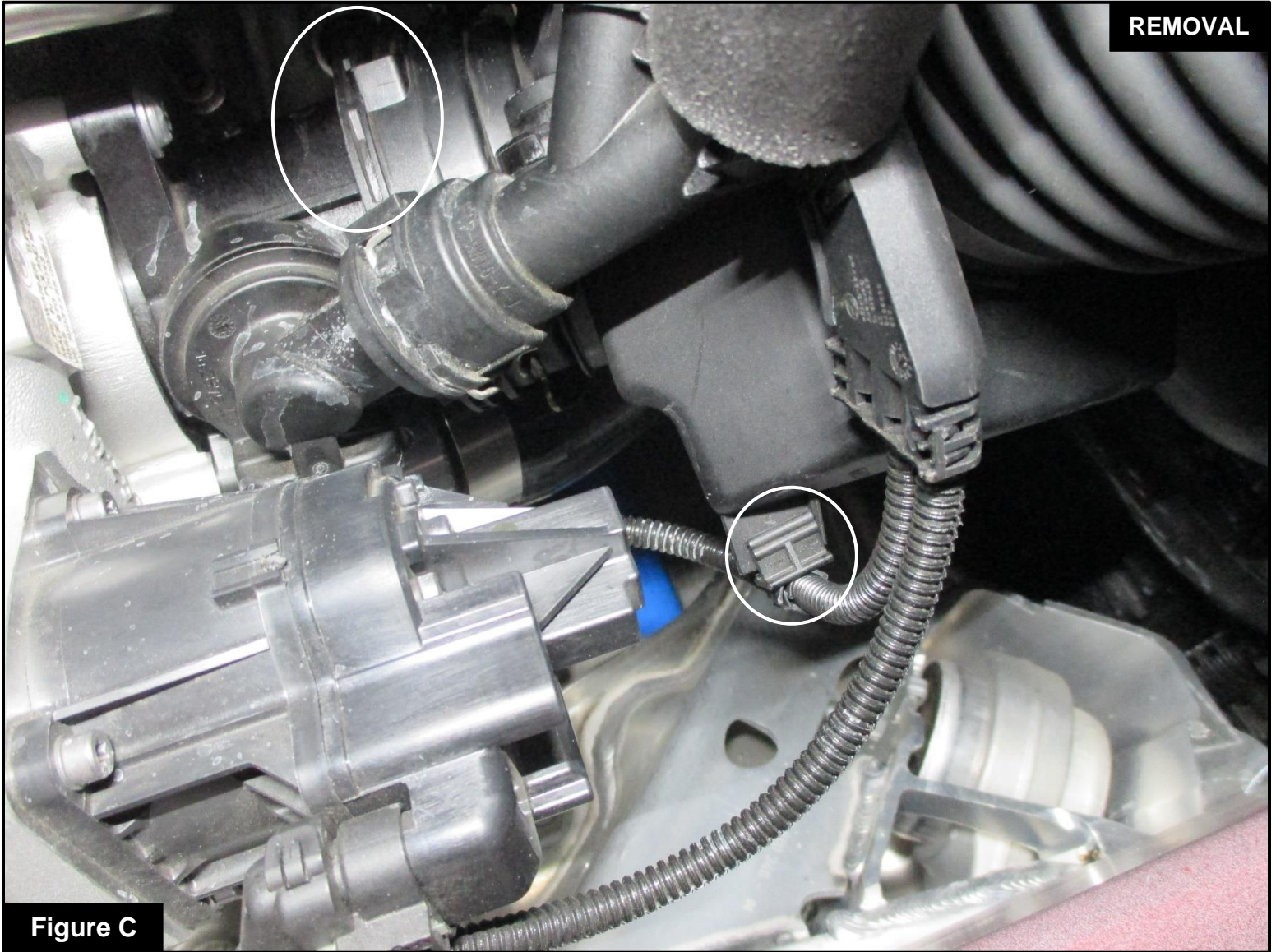

Figure C

**Refer to Figure C for Steps 6-7**

Step 6: Next, detach the harness from the factory intake tube.

Step 7: Finally, carefully remove the retention ring holding the factory intake tube to the turbo inlet and pull the factory intake tube out of the vehicle.

**Figure D****Refer to Figure D for Steps 8-9**

Step 8: Transfer the temperature sensor from the factory airbox to the Takeda intake tube and attach with the supplied screws.

Step 9: Install the supplied NPT fitting into the Takeda intake tube.

**NOTE: This is an NPT fitting. The small gap between the tube and hex is normal.**

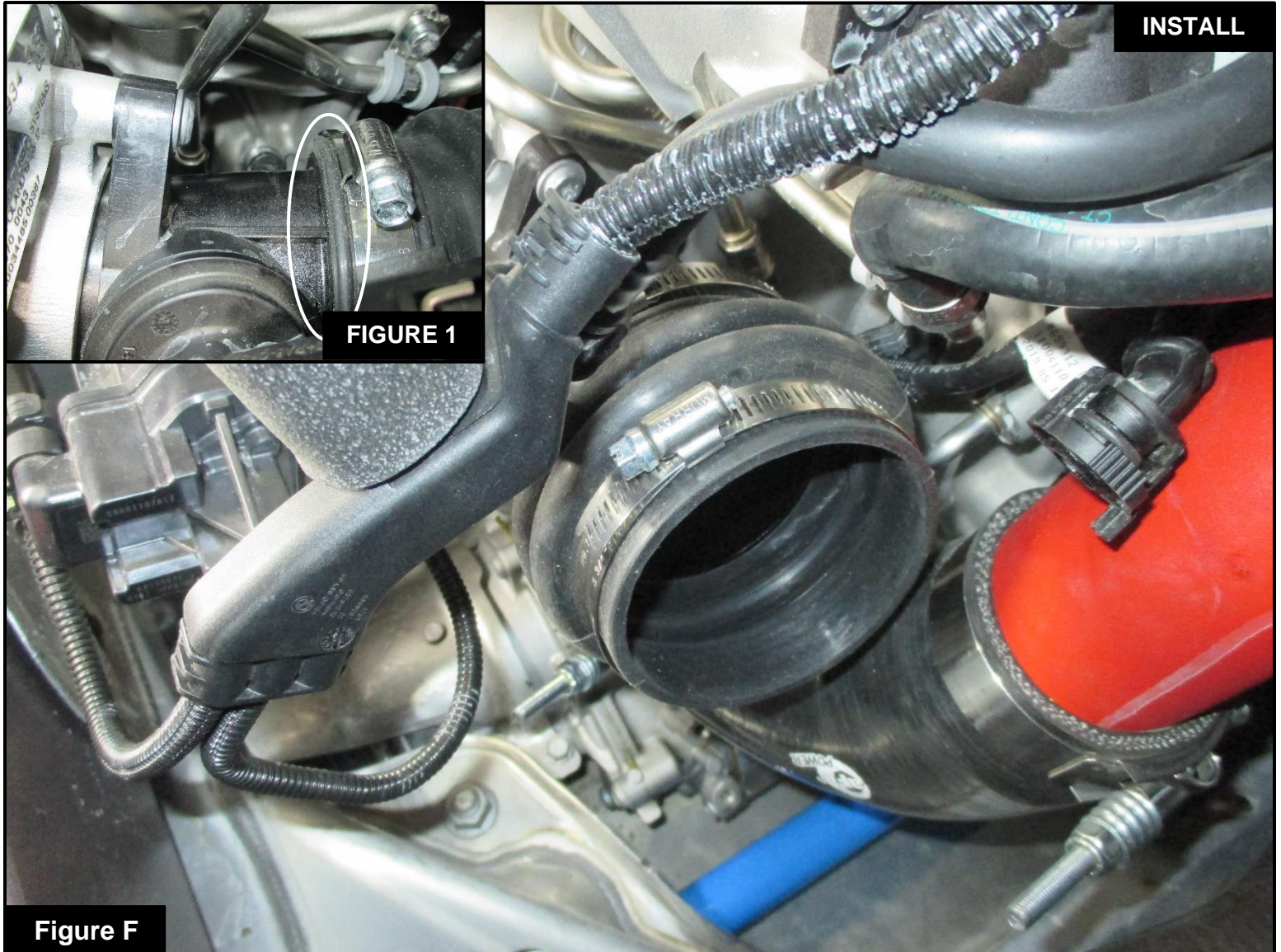

Figure E

**Refer to Figure E for Step 10**

Step 10: Install the supplied air filter into the Takeda housing by firmly pushing it into the Takeda housing until the filter tabs lock it into place. Install the clamp on the air filter, but do not tighten at this time.





**Refer to Figure F for Steps 11-13**

- Step 11: Install the supplied coupling onto the turbo inlet and place the supplied clamps onto the coupling.
- Step 12: Make sure to have the end of the coupling sit flush to the rim of the turbo inlet. This is to make sure the interior lip of the coupling sits correctly in the groove of the turbo inlet. See Figure 1.
- Step 13: When the coupling sits comfortably on the turbo inlet, tighten the clamp between the coupling and the turbo inlet.

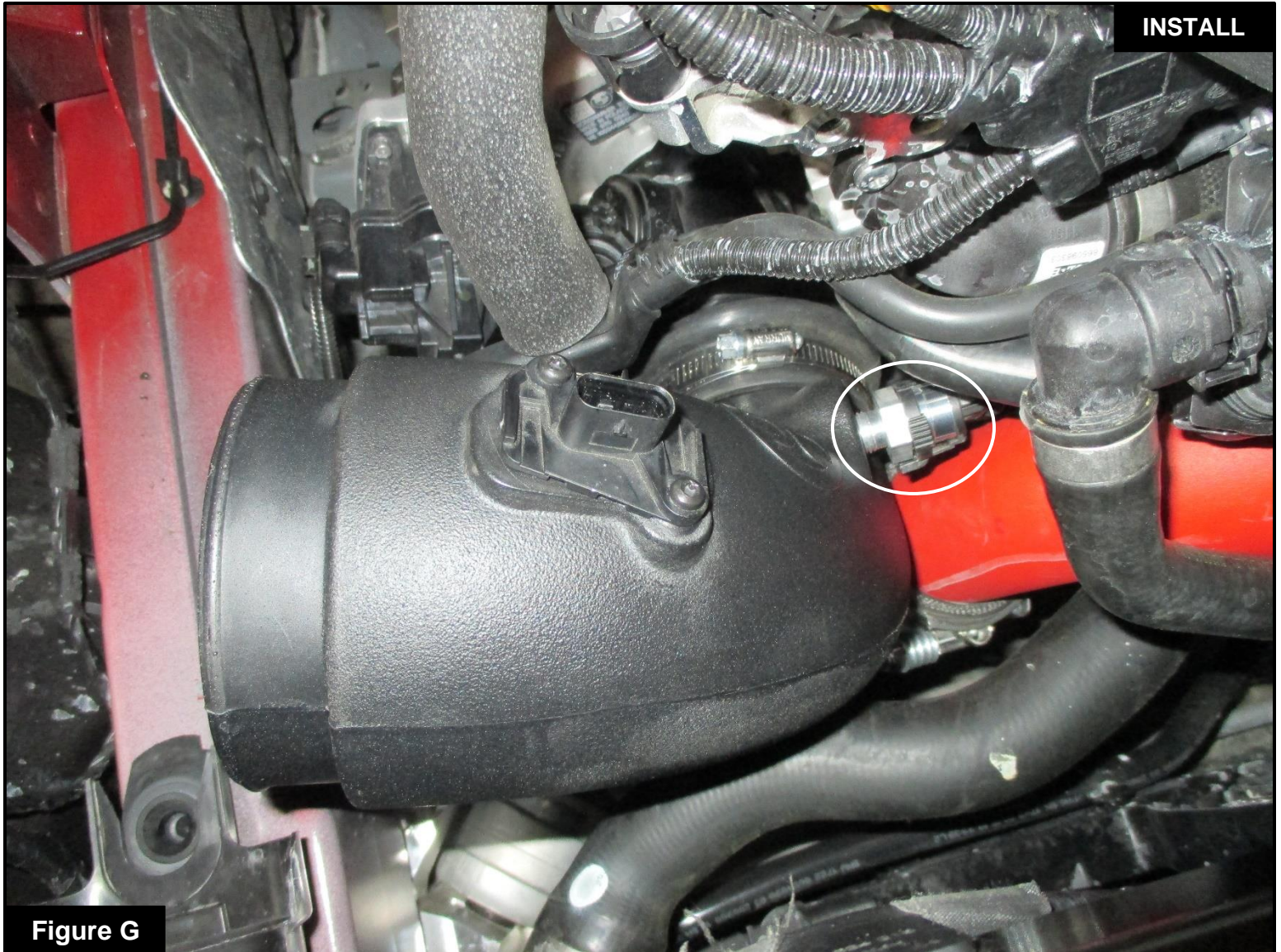

**Figure G**

**Refer to Figure G for Steps 14-16**

Step 14: Install the Takeda intake tube into the coupling. Do not tighten the clamp at this time.

Step 15: Connect the crankcase breather line to the Takeda intake tube.

Step 16: Make sure the Takeda intake tube and crackcase line sit comfortably, then tighten the clamp between the Takeda intake tube and the coupling.

**Figure H****Refer to Figure H for Steps 17-21**

Step 17: Install the assembled Takeda housing and air filter into the engine bay by pressing down firmly into the three (3) factory mounting grommets.

Step 18: Slip the Takeda tube into the air filter and tighten the clamp between the Takeda tube and air filter.

Step 19: Connect the temperature sensor to the sensor harness.

Step 20: If the vehicle is equipped with a brace, re-install the brace from **Step 1**.

Step 21: Make sure all components and connections are secure. Your installation is now complete. Thank you for choosing Takeda!

**NOTE: Check all bolts, clamps, and connectors after 100-200 miles.**

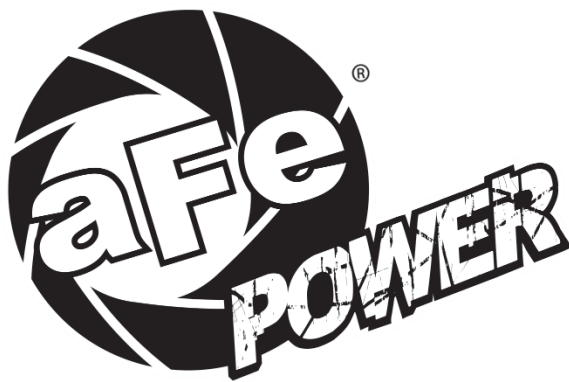

***advanced FLOW engineering, inc.***

Corona, CA 92879

<https://afepower.com/contact>