

advanced FLOW engineering Magnum FORCE Stage-2 Cold Air Intake System

Instruction Manual P/N: 54-13050D / 54-13050R

Make: Audi	Model: A3	Year: 2015-2018	Engine: L4-1.8L (t)
Make: Audi	Model: A3	Year: 2015-2020	Engine: L4-2.0L (t)
Make: Audi	Model: S3	Year: 2015-2020	Engine: L4-2.0L (t)
Make: Volkswagen	Model: Golf	Year: 2015-2018	Engine: L4-1.8L (t)
Make: Volkswagen	Model: Golf R	Year: 2015-2019	Engine: L4-2.0L (t)
Make: Volkswagen	Model: GTI	Year: 2015-2020	Engine: L4-2.0L (t)
Make: Volkswagen	Model: Jetta GLI	Year: 2019-2020	Engine: L4-2.0L (t)



- Please read the entire instruction manual before proceeding.
- Ensure all components listed are present.
- For technical support please call 951-493-7185.
- Ensure you have all necessary tools before proceeding.
- Do not attempt to work on your vehicle when the engine is hot.
- Retain factory parts for future use.

Label	Qty.	Description	Part Number
A1	1	Air Filter (Pro 5R)	24-91117
A2	1	Air Filter (Pro DRY S)	21-91117
B	1	Housing	05-5413049B2
C	1	Tube	05-76403B1
D	1	Seal, Trim: 3/4" Bulb (29"L)	05-01507
E	1	Coupling, Silicone Reducer	05-01196
F	1	Fitting, Smog Pump	05-01096
G	1	Cap, Smog Pump Fitting	03-50179
H	3	Grommet	03-50647
I	1	Clamp #048	03-50007
J	1	Clamp #044	03-50019
K	1	Grommet, Rubber	03-50139
L	1	Nipple, Brass Hose	03-50191

Installation will require the following tools:

7mm & 8mm nut drivers, 11mm wrench or adjustable wrench

Emissions Disclaimer: This product is not currently CARB exempt and is not available for purchase in California or for use on any vehicle registered with the California Department of Motor Vehicles.

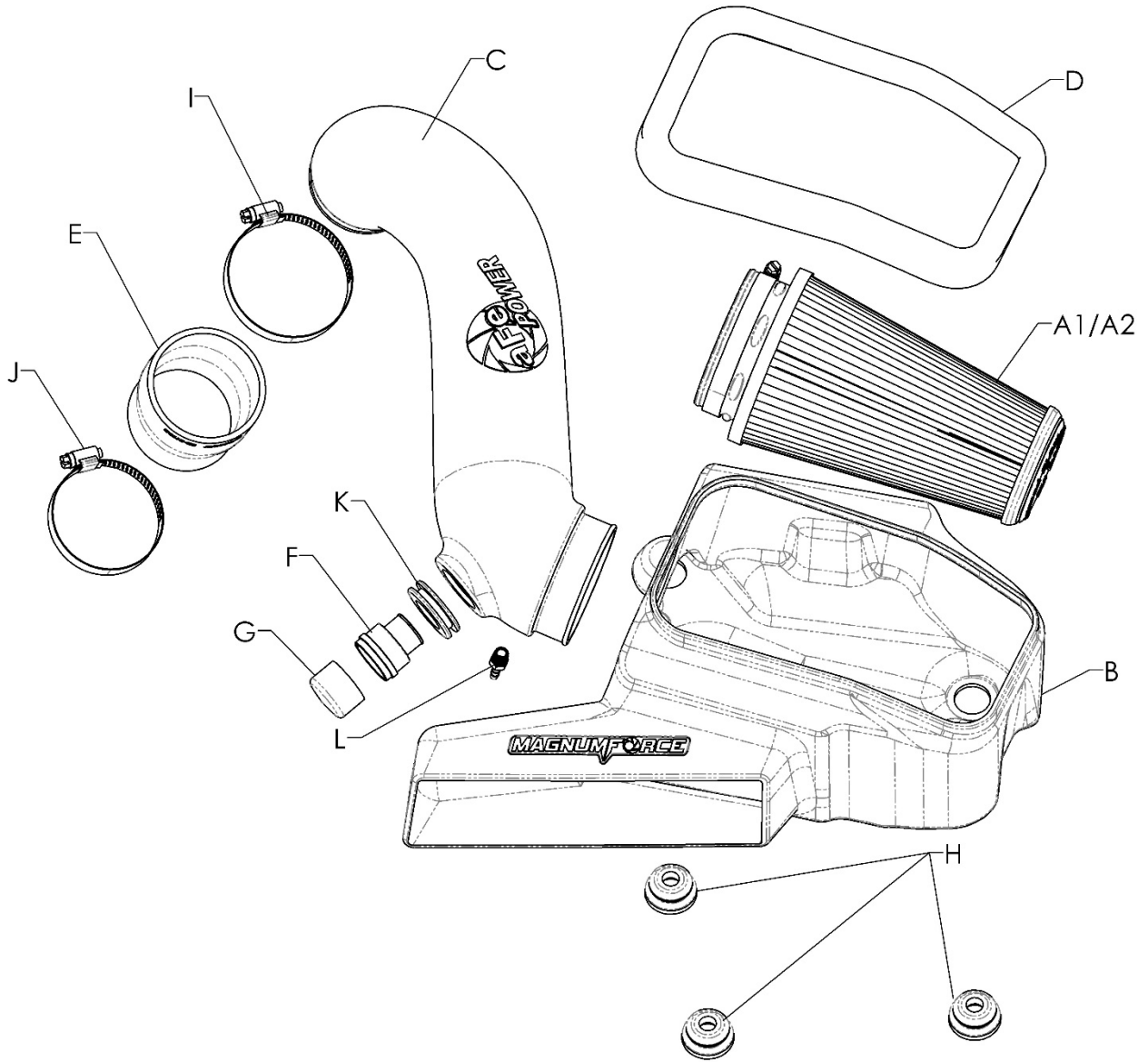



Refer to Figure A for Steps 1-4

Step 1: Disconnect the smog pump connector (1) from the factory filter housing. (If Applicable)

Step 2: Disconnect the rubber crank case breather line (2) from the factory filter housing.

Step 3: Using a 7mm nut driver, loosen the clamp (3) connecting the factory intake tube to the turbo inlet.

Step 4: Remove the factory filter housing and tube by pulling straight up off the mounting grommets.

INSTALL



Figure B

Refer to Figure B for Step 5

Step 5: Install the supplied grommets (4) in the three mounting holes on the bottom of your aFe Power housing as shown.



Figure C

Refer to Figure C for Step 6

Step 6: Install the supplied seal trim (5) along the top opening of the housing as shown. Trim to fit as necessary.

**Figure D****Refer to Figure D for Steps 7-9**

Step 7: Install the supplied flat grommet (6) into the 1" hole on your aFe Power intake tube.

Step 8: For vehicle equipped with a smog pump, install the supplied aluminum fitting (7) into the grommet. If your vehicle is not equipped with a smog pump, install the supplied cap into the grommet instead.

Step 9: Install the supplied brass fitting (8) into the intake tube. Tighten using an 11mm wrench or open face wrench.

**Figure E****Refer to Figure E for Step 10**

Step 10: Install the supplied reducer coupling (9) and #044 clamp (10) with the smaller side on the turbo inlet pipe. Tighten the clamp using an 8mm nut driver.



Refer to Figure F for Step 11

Step 11: Install your aFe Power filter housing into the vehicle by lining up the three grommets on the mounting pins on the factory battery tray. Press firmly to ensure it is in place.

**Figure G****Refer to Figure G for Step 12**

Step 12: Install your aFe Power air filter (11) into the housing through the top opening, ensuring that the retention bumps are on the outside of the housing. Place the filter clamp loosely on the filter opening.

**Figure H****Refer to Figure H for Step 13**

Step 13: Install your aFe Power intake tube (12) with the remaining #048 clamp (13) into the vehicle by inserting into the filter first, then rotating down into the coupling at the turbo inlet. Tighten all of the clamps using an 8mm nut driver.

**Figure I****Refer to Figure I for Steps 14-15**

Step 14: Reconnect the crank case breather line (14) to the fitting on the bottom of your intake tube.

Step 15: If your vehicle is equipped with a smog pump, connect the smog pump line (15) to the fitting installed on your intake tube.



Refer to Figure J for Step 16

Step 16: Confirm that all connections are secure and clamps tightened. Your installation is now complete.

Thank you for choosing aFe POWER!

NOTE: Check all screws, clamps, and connectors are secure after 100-200 mi

Pro DRY S Air Filter



P/N: 21-91117

Pro 5R Air Filter



P/N: 24-91117

Pre-Filter



P/N: 28-10063

Scorcher GT Power Module



P/N: 77-46408

Pro DRY S Restore Kit



P/N: 90-59999

Blue Squeeze Restore Kit



P/N: 90-50501

Sprint Booster



P/N: 77-16412

Cat-Back Exhaust System



P/N: 49-36418-B

Axle-Back Exhaust System



P/N: 49-36417-B

Street Series Down-Pipe



P/N: 48-36408-YC

Tactical Backpack



P/N: 40-33205-B

Power Bank



P/N: 40-10198

To purchase any of the items above, view airflow charts, dyno graphs, photos, and video; please go to aFepower.com.



Warranty

General Terms:

- aFe warrants their products to be free from manufacturer's defects due to workmanship and material.
- This warranty applies only to the original purchaser of the product and is non-transferrable.
- Proof of purchase of the aFe product is required for all warranty claims.
- Warranty is valid provided aFe instructions for installation and/or cleaning were properly followed.
- Proper maintenance with regular inspections of product is required to insure warranty coverage.
- Damage due to improper installation, abuse, unauthorized repair or alteration is not warranted.
- Incidental or consequential damages or cost, including installation and removal of part, incurred due to failure of aFe product is not covered under this warranty.
- All warranty is limited to the repair and/or replacement of the aFe part. To request Return Goods Authorization ("RGA"), email RGA@afepower.com or call (951)493-7100. Upon receipt of the RGA, you must return the product to the address provided in the RGA, freight prepaid and accompanied with a dated proof of purchase and the RGA. Upon receipt of the defective product and upon verification of proof of purchase, aFe will either repair or replace the defective product within a reasonable time, not to exceed thirty days.

Product Category	P/N Prefix	Warranty duration
Direct OE Replacement Filters	10, 11, 30, 31, 71, 73	Life of the vehicle
Racing Filters	18	1 year
Universal	20, 21, 23, 24, 72, TF	2 years
Air Intake Systems	50, 51, 53, 54, 55, 56, 57, 58, 75, TR, TA, TL, TM	2 years
Exhaust Systems	49	2 years
Intercoolers & Intercooler Tubes	46-2	2 years
Intake Manifolds	46-1	2 years
Differential Cover	46-7	Life of the vehicle
Exhaust Manifolds	46	2 years
Throttle Body Spacers	46-3	2 years
Turbochargers	46-6	2 years*
Fluid Filters	44	90 days
Pre-Filters	28	2 years
Heavy Duty OE Replacement	70	2 years
PowerSports OE Replacement	81, 87	2 years
PowerSports Intake Systems	85	2 years

No other warranty expressed or implied applies nor is any person or advanced FLOW engineering authorized to assume any other warranty. Some States do not allow the exclusion or limitation of incidental or consequential damages or do not allow limitations on how long an implied warranty lasts, so the above limitations or exclusions may not apply to you. This warranty gives you specific legal rights, and you may also have other rights which vary from State to State.

*See turbocharger warranty for more info

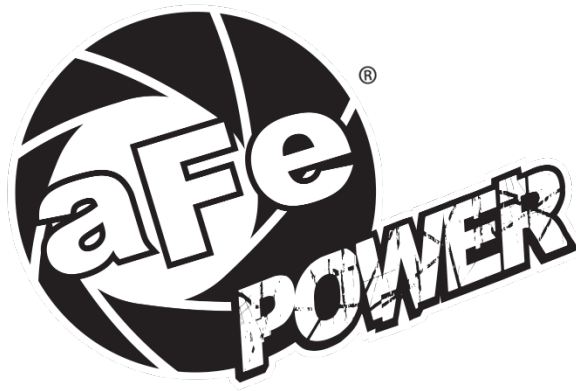

advanced FLOW engineering, inc.

252 Granite Street Corona, CA 92879
TEL: 951.493.7100 • TECH: 951.493.7185
E-Mail: Tech@aFepower.com

P/N: 06-81326