

# MOMENTUM<sup>TM</sup> GT

advanced FLOW engineering

Momentum GT Cold Air Intake System

## **Instruction Manual** P/N: 51-76902-1 / 54-76902-1

Make: Alfa Romeo  
Make: Alfa Romeo

Model: Giulia  
Model: Stelvio

Year: 2017-2021  
Year: 2017-2021

Engine: L4-2.0L (t)  
Engine: L4-2.0L (t)



- Please read the entire instruction manual before proceeding.
- Ensure all components listed are present.
- For technical support please call 951-493-7185.
- Ensure you have all necessary tools before proceeding.
- Do not attempt to work on your vehicle when the engine is hot.
- Retain factory parts for future use.

Label	Qty.	Description	Part Number
A1	1	Air Filter (Pro 5R)	24-91122
A2	1	Air Filter (Pro DRY S)	21-91122
B	1	Housing, Rotomold	05-76902B2
C	1	Intake Tube, Rotomold	05-76902B3
D	1	Vacuum Fitting (Plastic)	05-01601
E	1	Grommet, 05-01601 Fitting	03-50665
F	1	Vacuum Fitting (Aluminum)	03-50585
G	1	Grommet, 03-50585 Fitting	03-50167
H	1	Coupling, Bellows (3-1/2" ID x 3"L)	05-01389
I	1	Coupling, Turbo Inlet Adaptor	05-01604
J	1	Plug, 2.25" D	05-01482
K	2	Clamp, #044	03-50019
L	2	Clamp, #052	03-50008

**Installation will require the following tools:**

7mm, 8mm, and 10mm nut drivers or sockets and ratchet with 6" extension, 4mm hex driver, small flathead screwdriver

Warranty Information available at <https://afepower.com/contact#warranty>

**Emissions Disclaimer:** This product is not currently CARB exempt and is not available for purchase in California or for use on any vehicle registered with the California Department of Motor Vehicles.

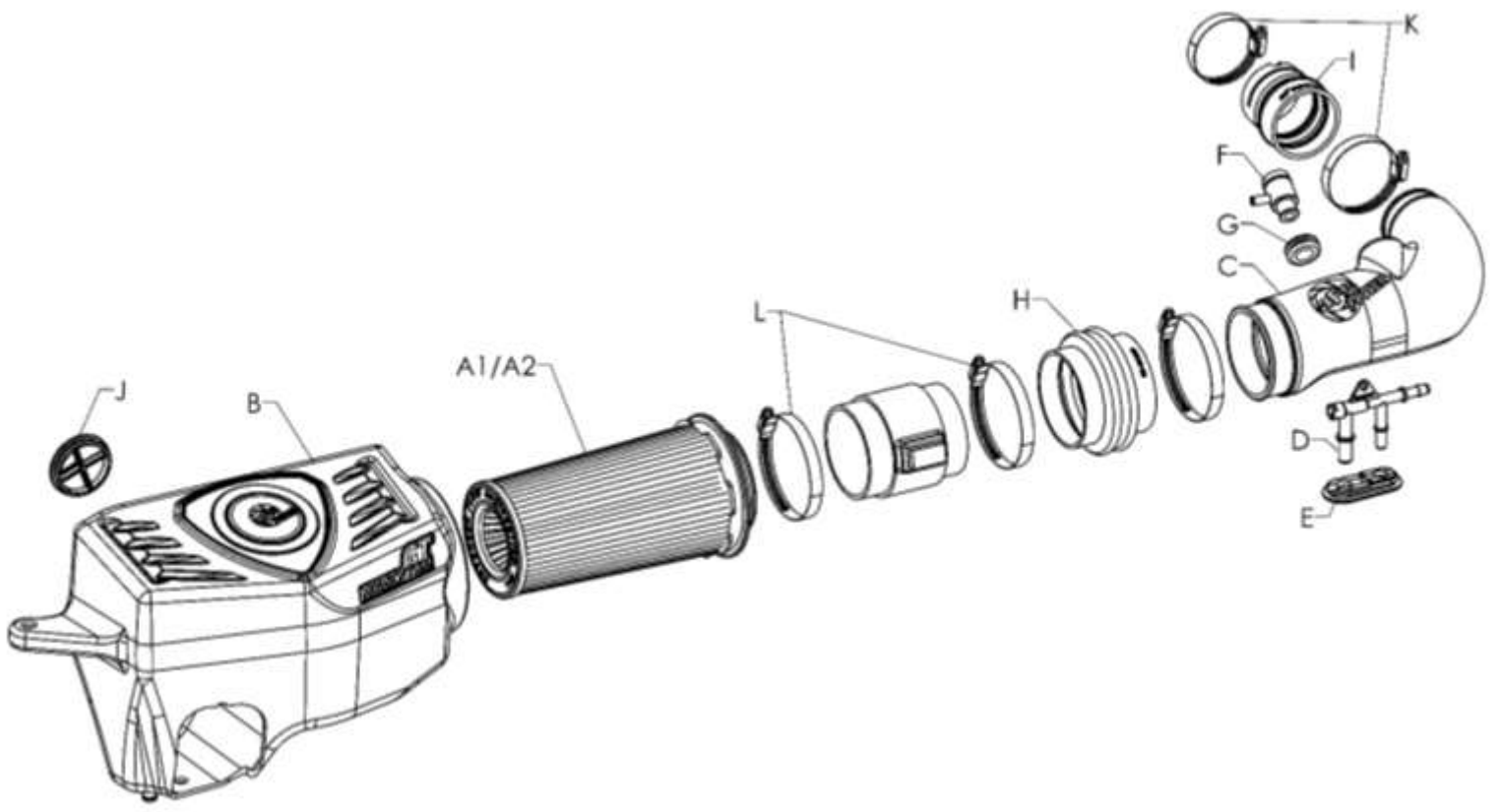



**Refer to Figure A for Step 1**

Step 1: Using a 10mm nut driver, remove the 2x screws ① securing the engine cover, then remove the cover.



**Figure B****Refer to Figure B for Step 2**

Step 2: Using a small flathead screwdriver, loosen the pinch clamp ② on the turbo inlet.

**Figure C****Refer to Figure C for Step 3**

Step 3: Disconnect the 2x quick disconnect fittings (3) on the bottom of the factory intake tube by pressing in the locking tabs, and pulling the fitting downward.



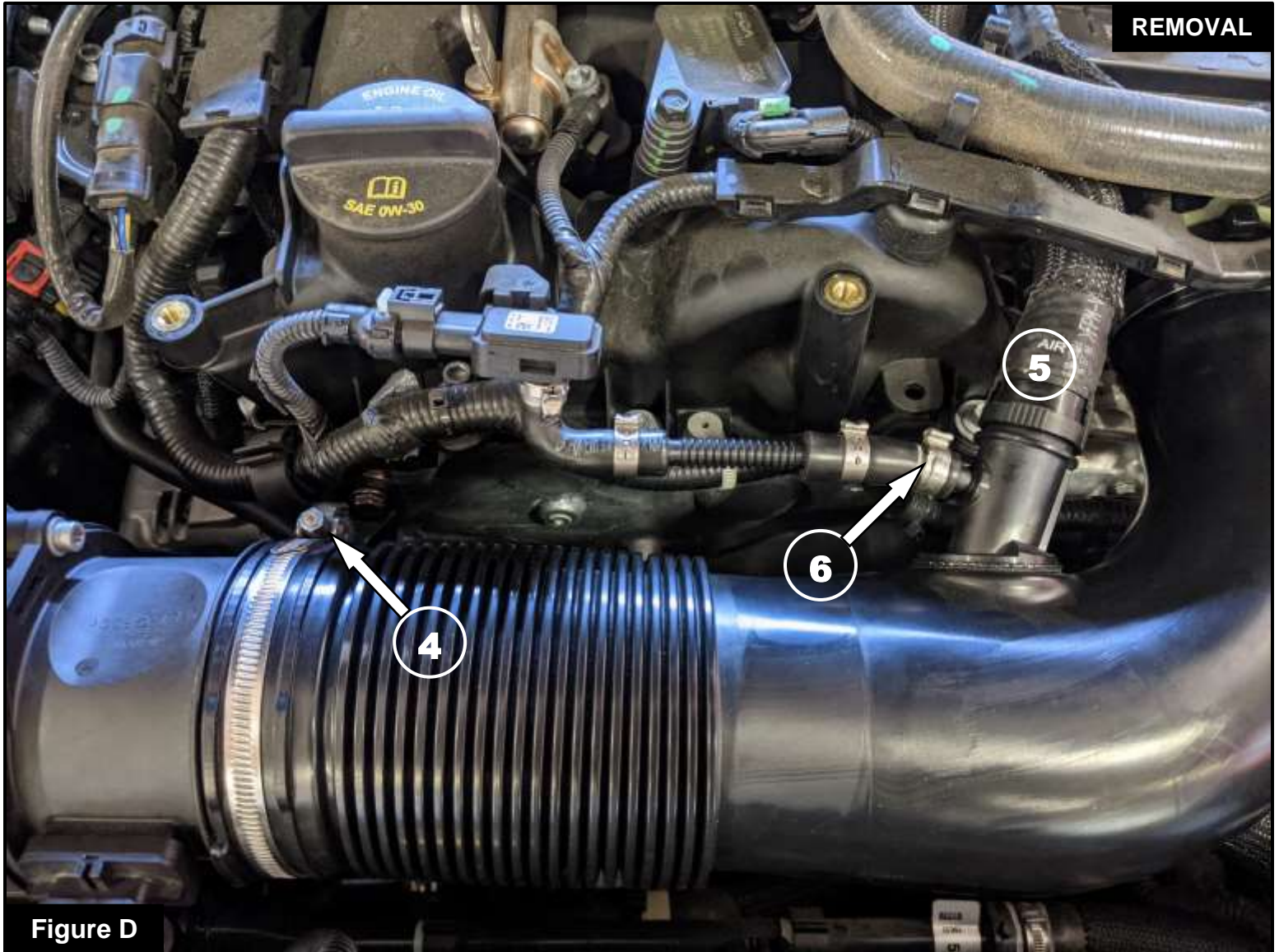

Figure D

**Refer to Figure D for Steps 4-6**

Step 4: Using a 7mm nut driver, loosen the clamp ④ securing the factory intake tube to the MAF sensor cartridge.

Step 5: Disconnect the larger vent hose ⑤ on the top of the factory intake tube, then loosen the pinch clamp using a small flathead screwdriver and disconnect the smaller vent hose ⑥.

Step 6: Remove the factory intake tube from the vehicle.

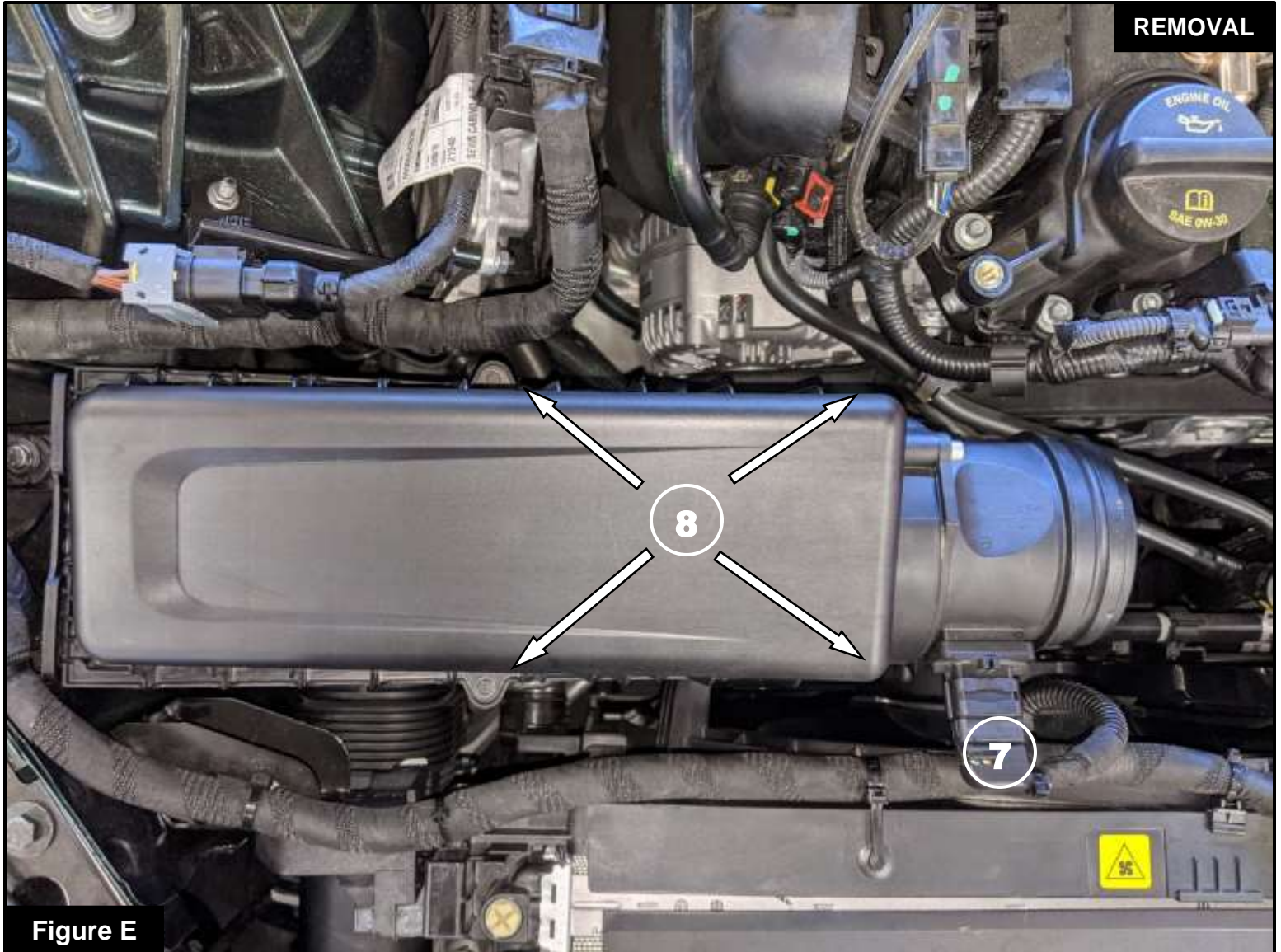

Figure E

**Refer to Figure E for Steps 7-8**

Step 7: Disconnect the mass airflow sensor (7).

Step 8: Using a 7mm nut driver, loosen the 4x screws (8) securing the top of the factory air filter housing. Remove the filter housing lid and air filter from the vehicle.





**Refer to Figure F for Step 9**

Step 9: Using a 10mm nut driver, remove the screw ⑨ securing the factory filter housing.

**Figure G****Refer to Figure G for Step 10**

Step 10: Disconnect the factory inlet duct (10) from inside the factory filter housing by pressing in the two tabs on the sides, then remove the bottom of the factory filter housing. Make sure the factory grommets stay in the vehicle.





**Figure H**

**Refer to Figure H for Step 11**

Step 11: Install your aFe POWER housing into the factory mounting locations. Reach into the housing to ensure it is seated correctly on the factory inlet duct. Secure the housing using the 10mm screw removed in step #9.





Figure 1

**Refer to Figure 1 for Step 12**

Step 12: Install your aFe POWER air filter into the housing, leaving the clamp loose.

**Figure J****Refer to Figure J for Step 13**

Step 13: Using a 4mm hex key, remove the 2x screws (11) securing the MAF cartridge to the top half of the factory filter housing. Remove the MAF cartridge, leaving the o-ring in the factory housing.



**Figure K****Refer to Figure K for Step 14**

Step 14: Install the supplied round grommet into your aFe POWER intake tube, then press the supplied aluminum fitting into the grommet as shown.





Figure L

**Refer to Figure L for Step 15-16**

Step 15: Insert the plastic vent fitting into the supplied grommet as shown, making sure the locking rings on the fitting are pressed fully through the holes on the grommet, but keeping the fitting in a raised position as shown (12).

Step 16: Install the fitting and grommet assembly into your aFe POWER intake tube, making sure the grommet is fully seated by pressing firmly around the edges. Once installed, pull the fitting down through the grommet to expose the entire quick connect portion (13).

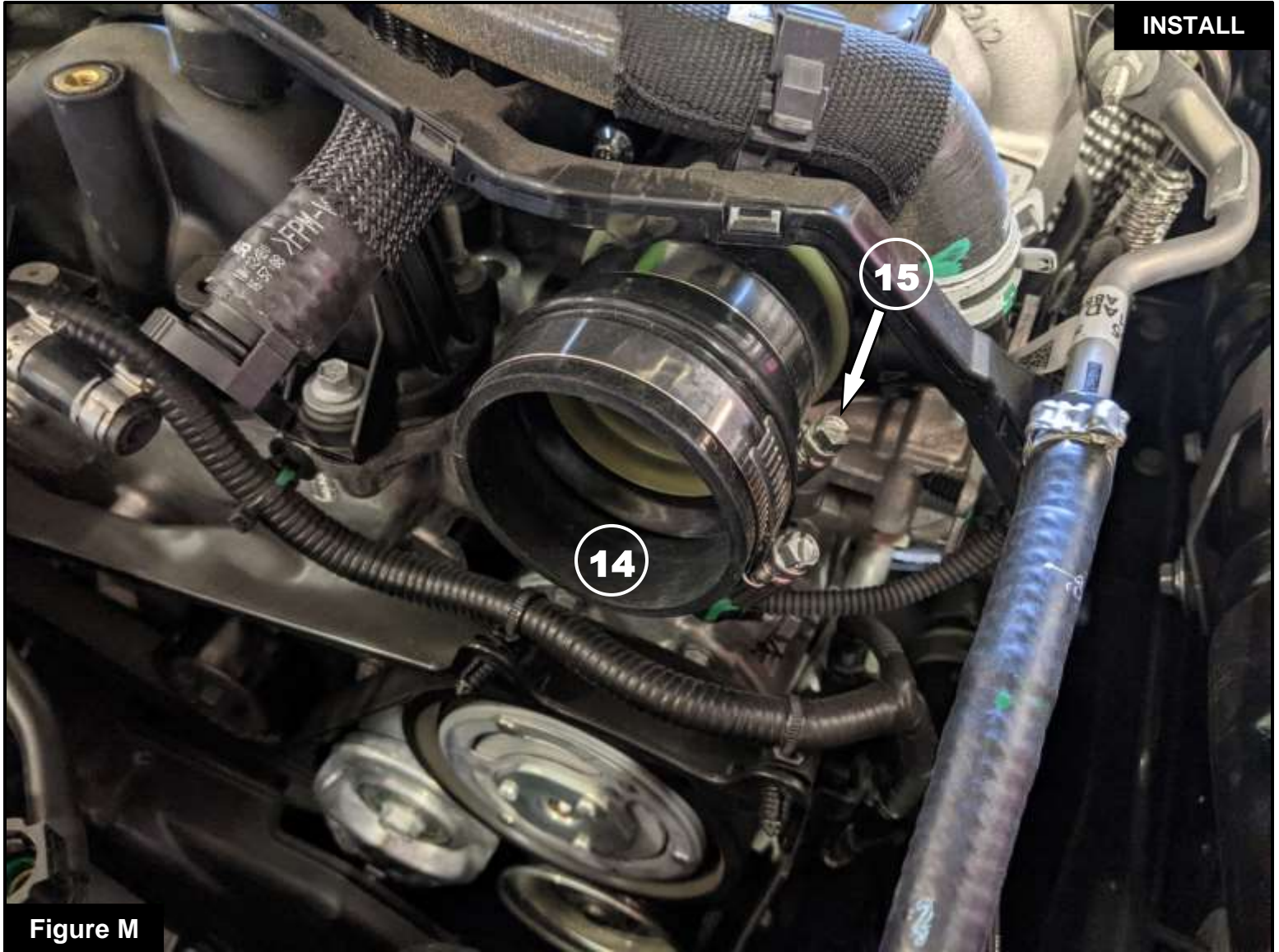

Figure M

**Refer to Figure M for Step 17**

Step 17: Install the supplied turbo adaptor coupling (14) and 2x #44 clamps onto the factory turbo inlet, lining up the index on the coupler to the index on the turbo inlet. Using an 8mm nut driver, tighten only the clamp on the turbo inlet side (15) .





**Refer to Figure N for Step 18**

Step 18: Install the factory MAF cartridge directly into your aFe POWER air filter with the mounting tabs on the filter side as shown. Rotate the cartridge so the sensor is angled approximately 45 degrees up from the front of the vehicle, then tighten the clamp on the air filter using an 8mm nut driver.



**Figure O****Refer to Figure O for Step 19**

Step 19: Install the supplied bellows coupler (16) and 2x #52 clamps onto the MAF cartridge. Using an 8mm nut driver, tighten only the clamp on the MAF cartridge side (17).



Figure P

**Refer to Figure P for Steps 20-21**

Step 20: Install your aFe POWER intake tube first into the bellow coupling, then into the turbo inlet coupler.

Tighten the clamps on both ends using an 8mm nut driver.

Step 21: Reconnect both vent fittings on the top side of the tube.

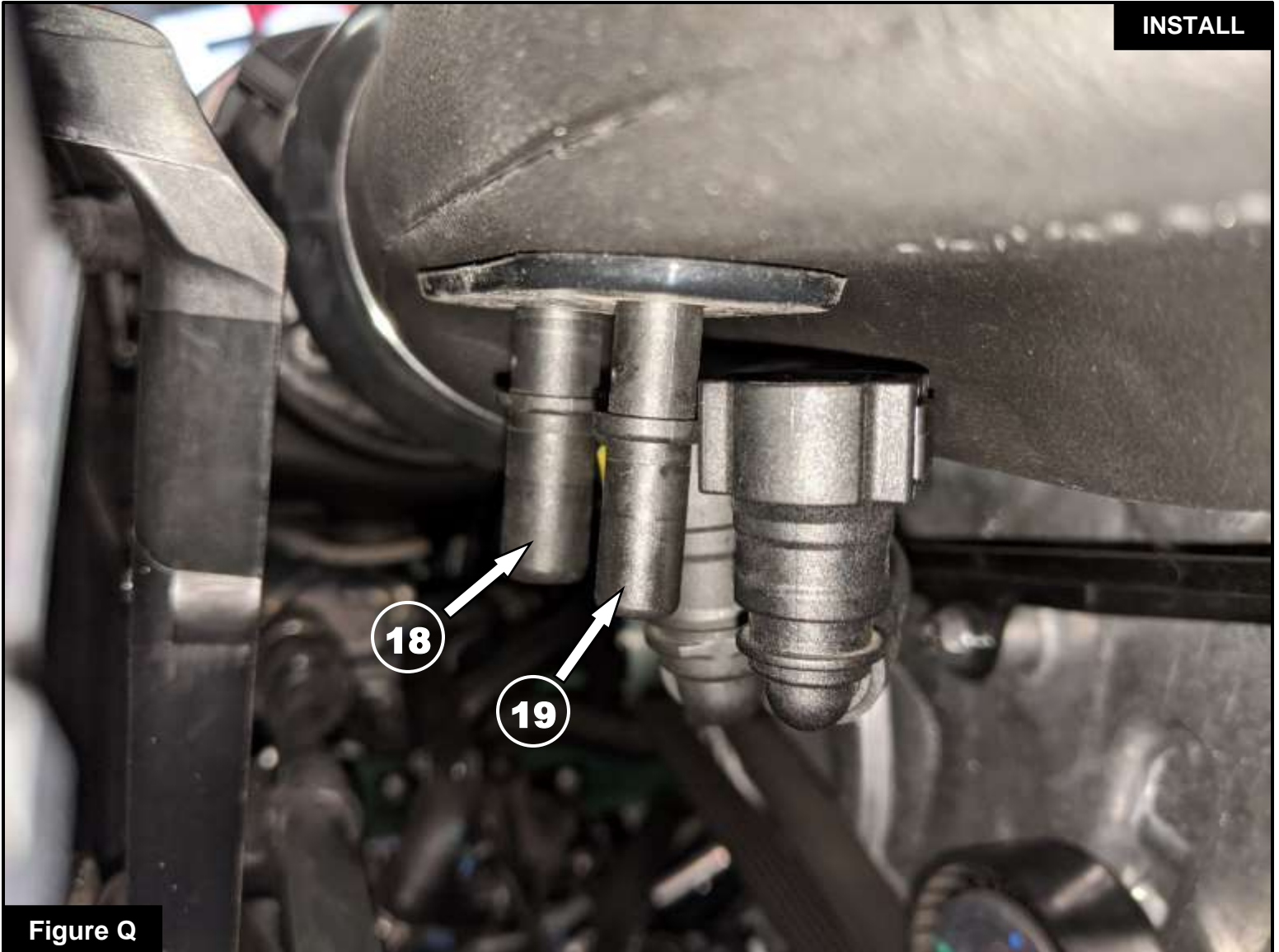

**Figure Q****Refer to Figure Q for Steps 22-23**

Step 22: To reconnect the fittings on the bottom of the intake tube, first pull down on the larger male fitting ⑱ while connecting the smaller fitting. Make sure the small fitting “clicks” into place.

Step 23: To reconnect the larger fitting, pull down on the smaller fitting ⑲ while connecting the large fitting. This will prevent the aFe POWER fitting from slipping through the grommet back into the tube. Make sure both fittings are fully connected and have “clicked” into place.



**Figure R**

**Refer to Figure R for Step 24-25**

Step 24: Reconnect the mass airflow sensor.

Step 25: Reinstall your engine cover using a 10mm nut driver.



**Figure S****Refer to Figure S for Step 26**

Step 26: (OPTIONAL) Install the supplied silicone plug (20) on the back side of your aFe POWER airbox to fully seal the intake system. Best flow and performance gains are seen with the plug removed. Your installation is now complete. Thank you for choosing aFe POWER!

**NOTE: Check all screws, clamps, and connectors are secure after 100-200 mi**



**PAGE LEFT BLANK INTENTIONALLY**





advanced FLOW engineering, inc.

252 Granite Street Corona, CA 92879

TEL: 951.493.7100 • TECH: 951.493.7185

E-Mail: [Tech@aFepower.com](mailto:Tech@aFepower.com)