

GT **MOMENTUM**

advanced FLOW engineering

Cold Air Intake System

Instruction Manual P/N: 50-70097D / 50-70097R

Make: BMW	Model: X1 (F48)	Year: 2016-2019	Engine: L4-2.0L (t) B46
Make: BMW	Model: X2 (F47)	Year: 2018-2019	Engine: L4-2.0L (t) B46
Make: MINI	Model: Cooper S (F55/F56)	Year: 2015-2019	Engine: L4-2.0L (t) B46
Make: MINI	Model: Countryman S (F60)	Year: 2017-2019	Engine: L4-2.0L (t) B46
Make: MINI	Model: Clubman S (F54)	Year: 2016-2019	Engine: L4-2.0L (t) B46



- Please read the entire instruction manual before proceeding.
- Ensure all components listed are present.
- If you are missing any of the components, call customer support at 951-493-7185.
- Ensure you have all necessary tools before proceeding.
- Do not attempt to work on your vehicle when the engine is hot.
- Retain factory parts for future use.

Label	Qty.	Description	Part Number
A1	1	Air Filter (Pro DRY S)	21-91097
A2	1	Air Filter (Pro 5R)	24-91097
B	1	Tube	05-5070097B1
C	1	Housing	05-5070068B2
D	1	Coupling, Silicone Bellow	05-01697
E	1	Clamp, #052	03-50008
F	1	Clamp, #048	03-50007
G	2	Screw, M4	03-50490
H	1	Auxiliary Plug	05-01482

Installation will require the following tools:

Socket set, socket wrench, flat-head screwdriver, T20 torx bit, and panel popper.

Warranty information available at <https://afepower.com/contact#warranty>.

Emissions Disclaimer:

This product is not currently CARB exempt and is not available for purchase in California or for use on any vehicle registered with the California Department of Motor Vehicles.

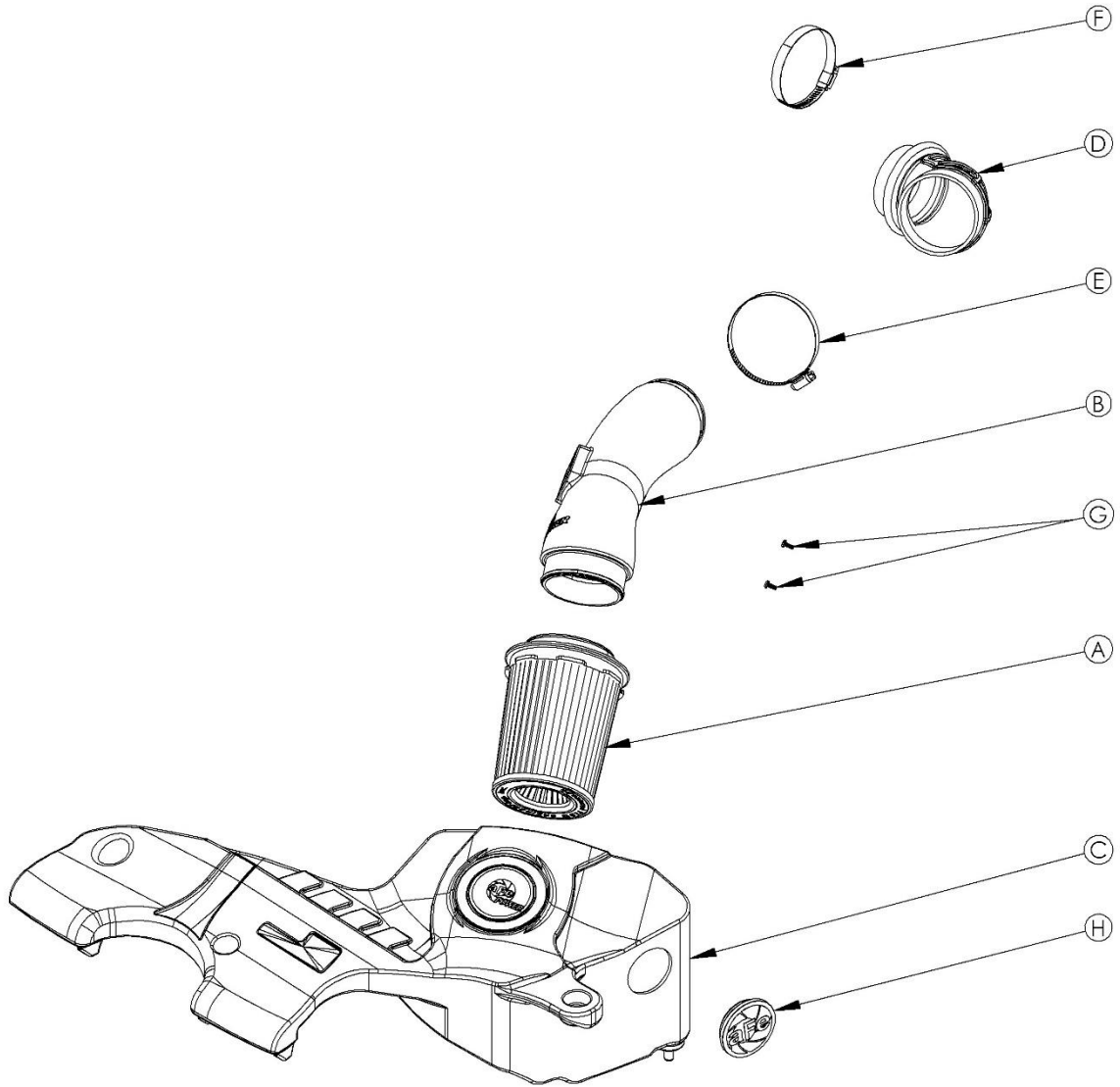



Figure A

Refer to Figure A for Step 1

Step 1: If the vehicle is equipped with a brace above the factory intake, remove the brace by following **Steps 2-7**. If no brace is equipped, skip to **Step 8**.

NOTE: This aFe POWER intake is design to fit with and without the factory brace.

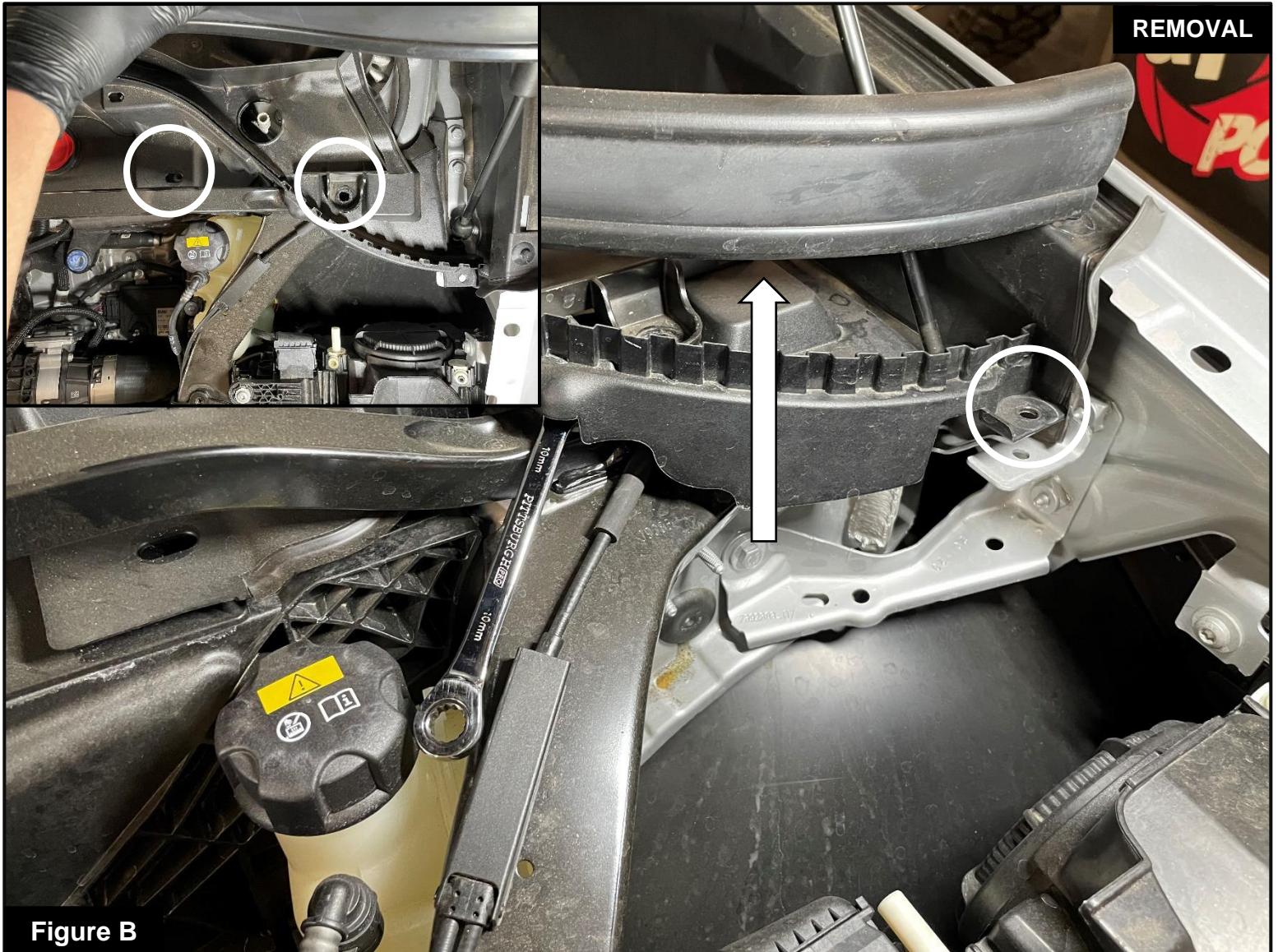

Figure B

Refer to Figure B For Steps 2-5

Step 2: Begin with the driver's side plastic cover. Remove the trim seal from the plastic panel by pulling up.

Step 3: With a panel popper, remove the two (2) clips holding the plastic panel.

Step 4: Remove the one screw, then remove the plastic cover from the vehicle.

Step 5: Repeat Steps 2-4 for the passenger's side plastic cover.

**Figure C****Refer to Figure C For Steps 6-7**

Step 6: Continuing to the passenger's side, use a 12mm socket to remove the two (2) bolts on the factory brace.

Step 7: Repeat Step 6 for the driver's side, then remove the brace from the vehicle.



Figure D

Refer to Figure D for Steps 8-9

Step 8: Remove the two (2) 10mm nuts holding the factory scoop. These nuts will be re-used.

Step 9: Remove the 10mm bolt holding the factory airbox. This bolt will be re-used.



Refer to Figure E for Steps 10-13

Step 10: Disconnect the Mass Air Flow (MAF) sensor harness.

Step 11: Using a 6mm nut driver, loosen the clamp on the factory housing.

Step 12: Remove the factory airbox from the engine bay.

Step 13: Remove the factory engine cover.

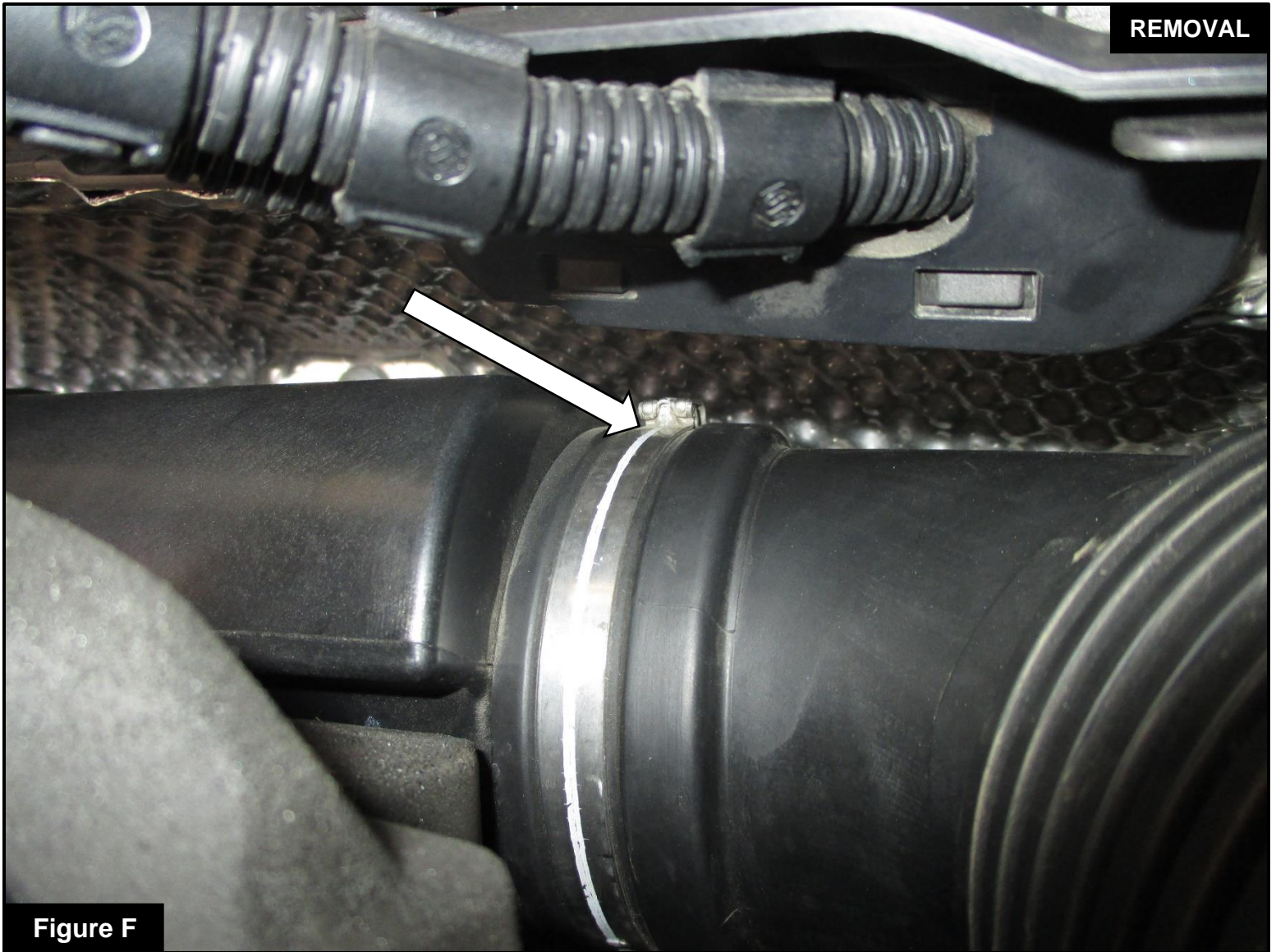

Figure F

Refer to Figure F for Steps 14-15

Step 14: Find the pinch clamp holding the factory intake tube to the factory intake resonator, sitting below the windshield cowl. With a flathead screw driver, loosen this clamp by twisting the screw driver and lifting up on the clamp's tabs.

Step 15: Remove the factory intake tube from the vehicle.

**Figure G****Refer to Figure G for Step 16**

Step 16: Transfer the MAF sensor from the factory airbox to the aFe POWER intake tube, and secure using the supplied screws.

**Figure H****Refer to Figure H for Steps 17-18**

Step 17: Transfer the factory grommets from the factory airbox into the aFe POWER housing.

Step 18: Install the supplied air filter into the aFe POWER housing until the air filter tabs at the base lock into place. Place the clamp over the air filter flange, but do not tighten at this time.

**Figure I****Refer to Figure I for Step 19**

Step 19: This kit includes an optional plug to close off the rear auxiliary air inlet. Install the plug if you wish to close it off to only capture cold air from the front.

NOTE: Without the plug installed, the aFe POWER intake will capture the maximum air available. More airflow offers more power. Some of this air is picked up from inside the engine compartment could be warmer air. Warmer air will affect the performance of the vehicle.

The plug installed on the housing will block off any hot engine air entering the housing to make sure the coolest air available is directed into the engine. The plug will also reduce the noise of the intake.

**Figure J****Refer to Figure J for Step 20**

Step 20: Install the supplied coupling onto the factory intake resonator and place the supplied clamps onto the coupling. Do not tighten the clamps at this time.



Figure K

Refer to Figure K for Steps 21-22

Step 21: Install the aFe POWER housing into the vehicle.

Step 22: Place the nuts and bolt from **Steps 8** and **9** onto the aFe POWER housing, but do not tighten at this time.

**Figure L****Refer to Figure L for Steps 23-25**

Step 23: Install the aFe POWER intake tube into the coupling, then into the aFe POWER air filter. Do not tighten the clamps at this time.

Step 24: Align the aFe POWER intake tube, housing, and coupling to sit properly.

Step 25: Connect the MAF harness to the MAF sensor on the aFe POWER intake tube.

NOTE: MAF sensor shown belongs to 2020 BMW L4-2.0L (t) B46.



Figure M

Refer to Figure M for Steps 26-30

Step 26: Tighten the factory nuts and bolts to secure the aFe POWER housing.

Step 27: Tighten the clamps at the coupling, then the clamp at the air filter.

Step 28: Re-install the factory engine cover.

Step 29: If the vehicle is equipped with a brace, re-install the brace from **Step 1**.

Step 30: Make sure all components and connections are secure. Your installation is now complete. Thank you for choosing aFe POWER!

NOTE: MAF sensor shown belongs to 2020 BMW L4-2.0L (t) B46.

Check all bolts, clamps, and connectors after 100-200 miles.



Page left blank intentionally.



Page left blank intentionally.



Page left blank intentionally.



advanced FLOW engineering, inc.

252 Granite Street Corona, CA 92879

<https://afepower.com/contact>

6/23/2022 JTP