

advanced FLOW engineering Momentum GT Cold Air Intake System

Instruction Manual P/N: 50-70046R / 50-70046D

Make: SUZUKI

Model: JIMNY

Year: 2019-2020

Engine: L4-1.5L



- Please read the entire instruction manual before proceeding.
- Ensure all components listed are present.
- If you are missing any of the components, call customer support at 951-493-7185.
- Ensure you have all necessary tools before proceeding.
- Do not attempt to work on your vehicle when the engine is hot.
- Retain factory parts for future use.

Label	Qty.	Description	Part Number
A1	1	Air Filter (Pro 5R) For 50-70046R	24-91155
A2	1	Air Filter (Pro DRY S) For 50-70046D	21-91155
B	1	Tube, Silicone	05-5070046B1
C	1	Housing, Plastic	05-5070046B2
D	1	Inlet Scoop, Plastic	05-5070046B3
E	1	Coupling, Silicone: 3-3/4"ID x 3"L	05-01509
F	1	Clamp, 032 (1-9/16" -2-1/2")	03-50016
G	2	Clamp, 060 (3-5/16" - 4-1/4")	03-50002

Installation will require the following tools:

8mm & 10mm nut drivers or ratchet and sockets, pliers or flat-head screwdriver

Emissions Disclaimer: This product does not require a CARB EO# (Vehicle does not exist in U.S.)

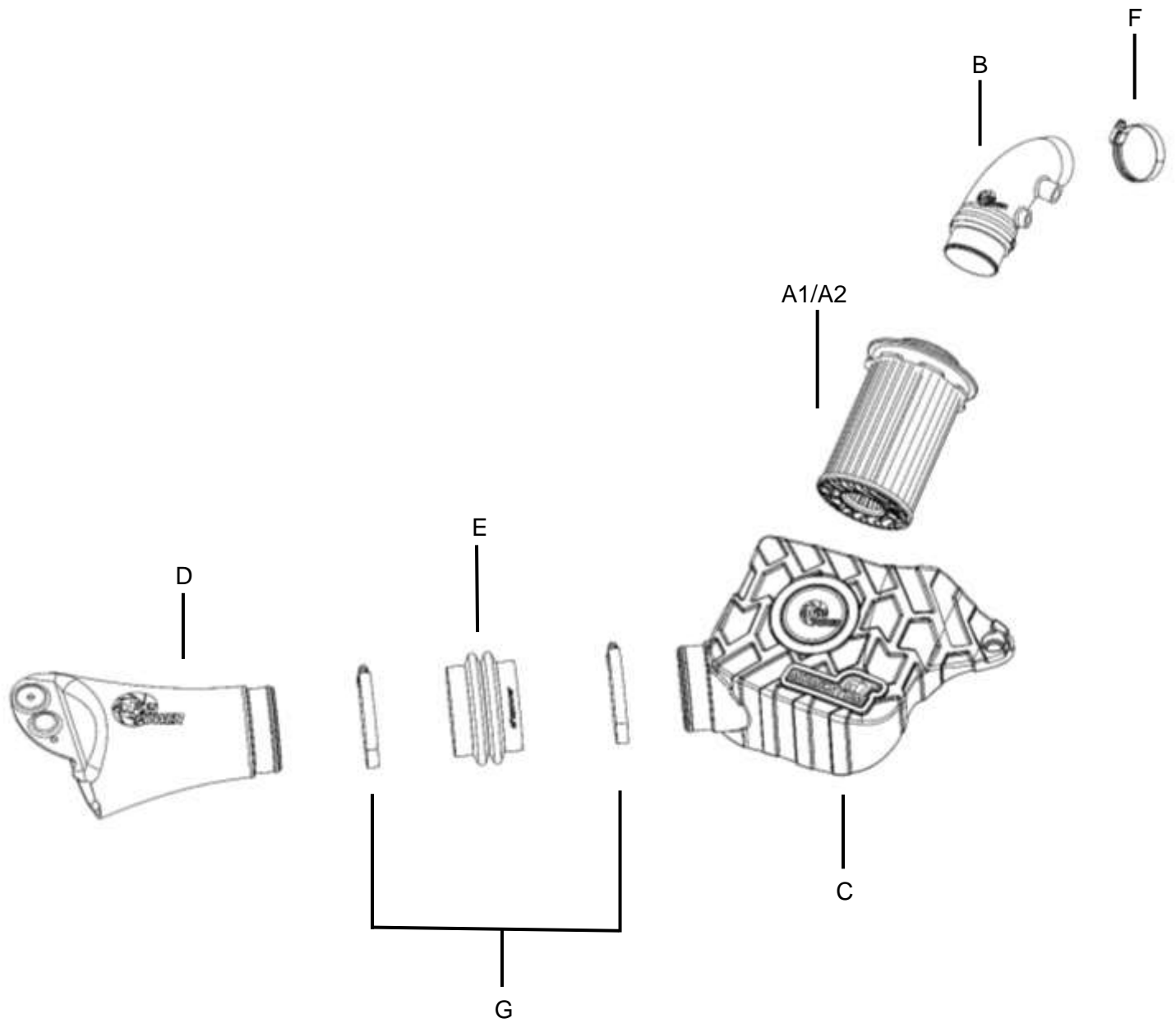

**Figure A****Refer to Figure A for Steps 1-2**

Step 1: Remove the two screws securing the inlet scoop. Those screws will be reused to secure the aFe POWER scoop.

Step 2: Remove the screw securing the factory housing to the engine. This screw will be reused to secure the aFe POWER housing.

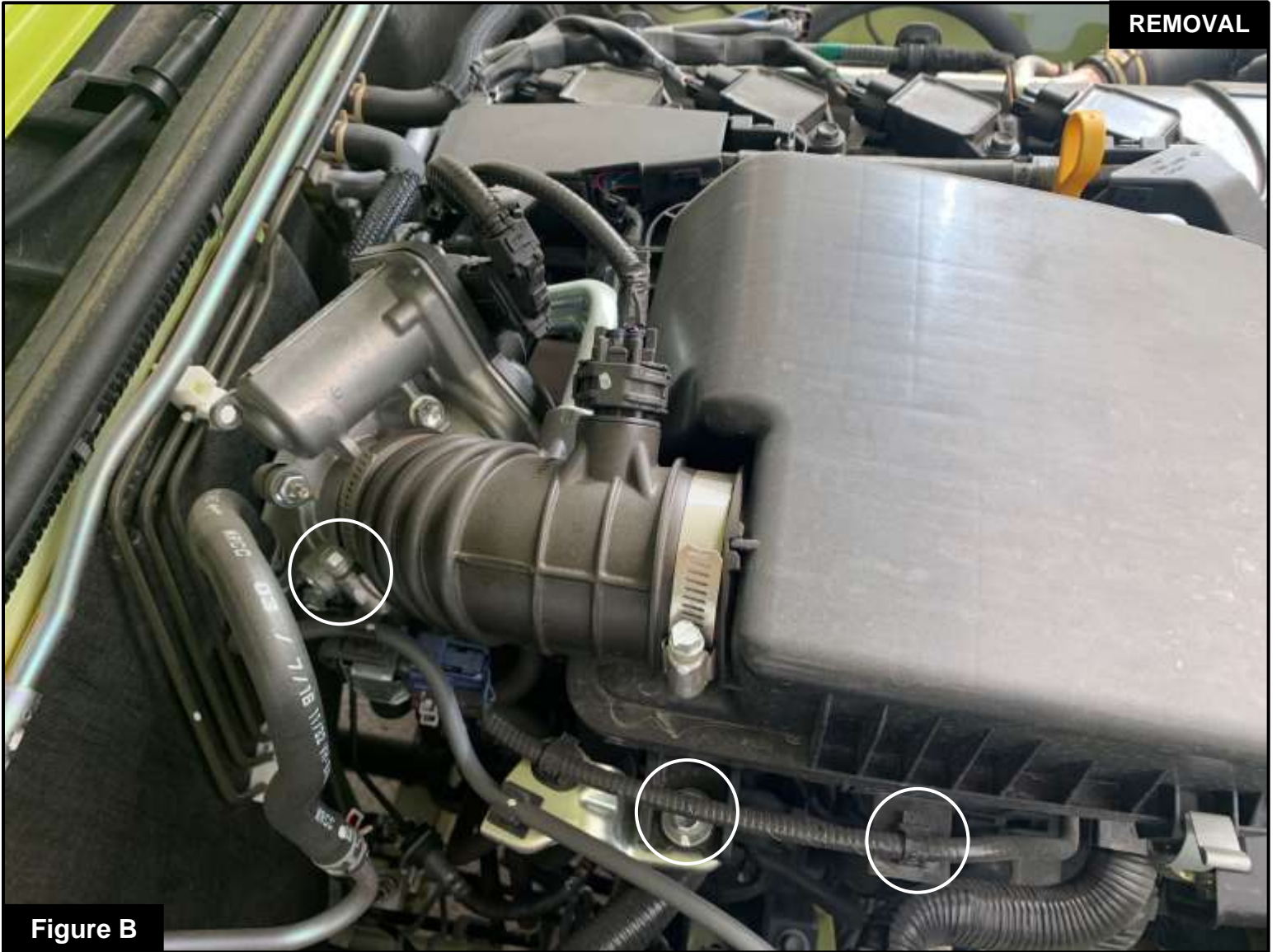
**Figure B****Refer to Figure B for Steps 3-5**

Step 3: Remove the second screw securing the factory housing to the mounting bracket. This screw will also be reused to secure the aFe POWER housing.

Step 4: Using pliers, unclip the harness from the factory housing.

Step 5: Untighten the clamp securing the factory intake tube to the throttle body.



Figure C

Refer to Figure C for Steps 6-7

Step 6: Disconnect the harness from the temperature sensor on the factory intake tube.

Step 7: Pull the metal tube out of the factory intake tube.



Figure D

Refer to Figure D for Steps 8-9

Step 8: Remove the full factory air intake system as one piece by pulling the factory intake tube off the throttle body and the factory housing off its grommet.

Step 9: Make sure the grommet under the housing stays in position. This mount will be reused for the aFe POWER housing.

**Figure E****Refer to Figure E for Steps 10-11**

Step 10: Transfer the two grommets with metal sleeves from the factory housing to the aFe POWER Housing.

Step 11: Slide the aFe POWER air filter into the aFe POWER housing and push it in until it locks into place. Install the clamp on the filter, but do not tighten the clamp at this time.



Figure F

Refer to Figure F for Step 12

Step 12: Remove the temperature sensor from the factory tube and install it into the aFe POWER tube.



Figure G

Refer to Figure G for Steps 13-14

Step 13: Connect the aFe POWER tube to the filter.

Step 14: Install the smaller clamp on the aFe POWER tube end, and the filter clamp on the filter end but do not tighten at this time.



Figure H

Refer to Figure H for Steps 15-16

Step 15: Install the aFe POWER housing and tube assembly in the vehicle. Slide the tube over the throttle body then press the housing peg into the grommet from steps 8 and 9.

Step 16: Align the tube, filter, and housing then press the metal tube into the aFe POWER tube.

**Figure I****Refer to Figure I for Steps 17-19**

Step 17: Secure the aFe POWER housing using the factory screws removed at step 2 and 3.

Step 18: Tighten all clamps.

Step 19: Reconnect the harness to the temperature sensor.

**Figure J****Refer to Figure J for Steps 20-21**

Step 20: Install the bellow coupling onto the opening of the aFe POWER housing.

Step 21: Place the clamps on the coupling but do not tighten yet.



Figure K

Refer to Figure K for Steps 22-24

Step 22: Install the aFe POWER scoop into the bellow coupling.

Step 23: Secure the scoop to the fender using the two screws removed at step 1.

Step 24: Tighten all clamps.

**Figure L****Refer to Figure L for Step 25**

Step 25: Verify all clamps and connections are secured. Your installation is now complete. Thank you for choosing aFe POWER!



PAGE LEFT BLANK INTENTIONALLY



PAGE LEFT BLANK INTENTIONALLY

Pro DRY S Air Filter



P/N: 21-91151

Pro 5R Air Filter



P/N: 24-91151

Pre-Filter



P/N: 28-10083

Sprint Booster V3



P/N: 77-17002

Pro Dry S Restore Kit



P/N: 90-50500

Pro 5R Restore Kit



P/N: 90-50501

Flashlight LED



P/N: 40-10202

Mechanic Gloves (L)



P/N: 40-10149

To purchase any of the items above, view airflow charts, dyno graphs, photos, and video; please go to aFepower.com.



Warranty

General Terms:

- aFe warrants their products to be free from manufacturer's defects due to workmanship and material.
- This warranty applies only to the original purchaser of the product and is non-transferrable.
- Proof of purchase of the aFe product is required for all warranty claims.
- Warranty is valid provided aFe instructions for installation and/or cleaning were properly followed.
- Proper maintenance with regular inspections of product is required to insure warranty coverage.
- Damage due to improper installation, abuse, unauthorized repair or alteration is not warranted.
- Incidental or consequential damages or cost, including installation and removal of part, incurred due to failure of aFe product is not covered under this warranty.
- All warranty is limited to the repair and/or replacement of the aFe part. To request Return Goods Authorization ("RGA"), email RGA@afepower.com or call (951)493-7100. Upon receipt of the RGA, you must return the product to the address provided in the RGA, freight prepaid and accompanied with a dated proof of purchase and the RGA. Upon receipt of the defective product and upon verification of proof of purchase, aFe will either repair or replace the defective product within a reasonable time, not to exceed thirty days.

Product Category	P/N Prefix	Warranty duration
Direct OE Replacement Filters	10, 11, 30, 31, 71, 73	Life of the vehicle
Racing Filters	18	1 year
Universal	20, 21, 23, 24, 72, TF	2 years
Air Intake Systems	50, 51, 53, 54, 55, 56, 57, 58, 75, TR, TA, TL, TM	2 years
Exhaust Systems	49	2 years
Intercoolers & Intercooler Tubes	46-2	2 years
Intake Manifolds	46-1	2 years
Differential Cover	46-7	Life of the vehicle
Exhaust Manifolds	46	2 years
Throttle Body Spacers	46-3	2 years
Turbochargers	46-6	2 years*
Fluid Filters	44	90 days
Pre-Filters	28	2 years
Heavy Duty OE Replacement	70	2 years
PowerSports OE Replacement	81, 87	2 years
PowerSports Intake Systems	85	2 years

No other warranty expressed or implied applies nor is any person or advanced FLOW engineering authorized to assume any other warranty. Some States do not allow the exclusion or limitation of incidental or consequential damages or do not allow limitations on how long an implied warranty lasts, so the above limitations or exclusions may not apply to you. This warranty gives you specific legal rights, and you may also have other rights which vary from State to State.

*See turbocharger warranty for more info



advanced FLOW engineering, inc.

252 Granite Street Corona, CA 92879

TEL: 951.493.7100 • TECH: 951.493.7185

E-Mail: Tech@aFepower.com

P/N: 06-81368