



AEROMOTIVE
Part # 18638
86-98 Ford Mustang Fuel Pump and Hanger
INSTALLATION INSTRUCTIONS

CAUTION:

Installation of this product requires detailed knowledge of automotive systems and repair procedures. We recommend that this installation be carried out by a qualified automotive technician.

Installation of this product requires handling of gasoline. Ensure you are working in a well ventilated area with an approved fire extinguisher nearby. Extinguish all open flames, prohibit smoking and eliminate all sources of ignition in the area of the vehicle before proceeding with the installation.

When installing this product, wear eye goggles and other safety apparel as needed to protect yourself from debris and sprayed gasoline.

WARNING!

The fuel system is under pressure. Do not open the fuel system until the pressure has been relieved. Refer to the appropriate vehicle service manual for the procedure and precautions for relieving the fuel system pressure.

Aeromotive system components are not legal for sale or use on emission controlled motor vehicles.

This kit contains the following parts:

- 1 ea Fuel Pump and Hanger Assembly
- 1 ea Fuel Strainer
- 1 ea Locking Ring
- 1 ea Locking Ring Gasket

Additional recommended parts:

- 1 ea 10-m fuel filter such as PN 12347 for AN-06 fuel lines (EFI) or P/N 12377 for AN-08 fuel lines (carbureted).
- 1 ea Bypass fuel pressure regulator such as PN 13303 for EFI applications or PN 13304 for carbureted engines.
- 1 ea Fuel Pump wiring kit such as PN 16307.
- 1 ea 5.0 stock fuel rail inlet adapter such as P/N 15124 and return adapter P/N 15123
- 1 ea 5.0 stock fuel rail regulator such as P/N 13103 for '86-'93 engines or P/N 13102 for '94-'98 engines.
- 2 ea outlet and return adapter fitting such as Fragola 499206BL for AN-06 or Fragola 499207BL for AN-08.

The following steps are typical of most installations:

1. Once the engine has been allowed to cool, disconnect the negative battery cable and relieve the fuel system pressure.
2. Raise the vehicle and support it with jack stands.
3. Referring to the appropriate vehicle service manual for instructions, drain and disconnect any fuel and electrical component connections and remove the OEM fuel tank. The removal of the vehicles exhaust system may be necessary for fuel tank removal.

4. Remove the old OEM fuel pump and hanger assembly.
5. Install the fuel pump strainer (pre-filter) on the fuel pump.



6. Place the locking ring gasket in the receiver groove on the tank.
7. Place the new Aeromotive fuel pump assembly in the tank. You may find it easiest to insert the pump through the opening and then slide the return line through once the pump is inside the tank. Once both the pump and return line are positioned inside the tank, look through the filler tube hole in the side of the tank to ensure that the pump and return line are both inside the fuel tank sump.
8. Ensure that the fuel pump locking ring gasket is still positioned properly in the receiver groove and then install the locking ring.

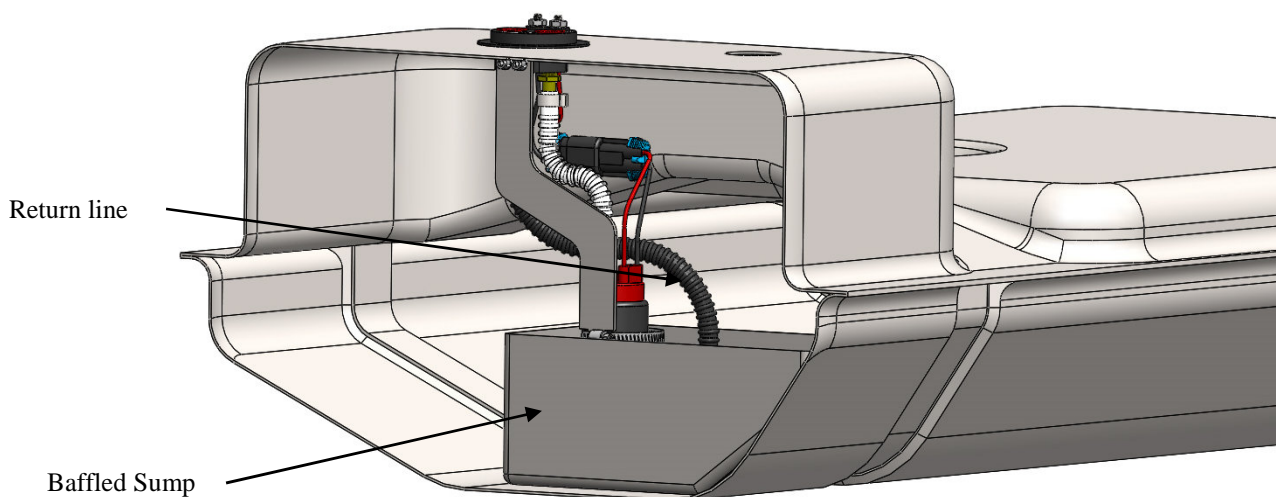

9. Install either ORB-06 x AN flare 90-deg fittings with the AN male sized to match your fuel lines (for AN-06 line use Fragola PN 499206BL; for AN-08 line use Fragola PN 499207BL, or other like fittings).

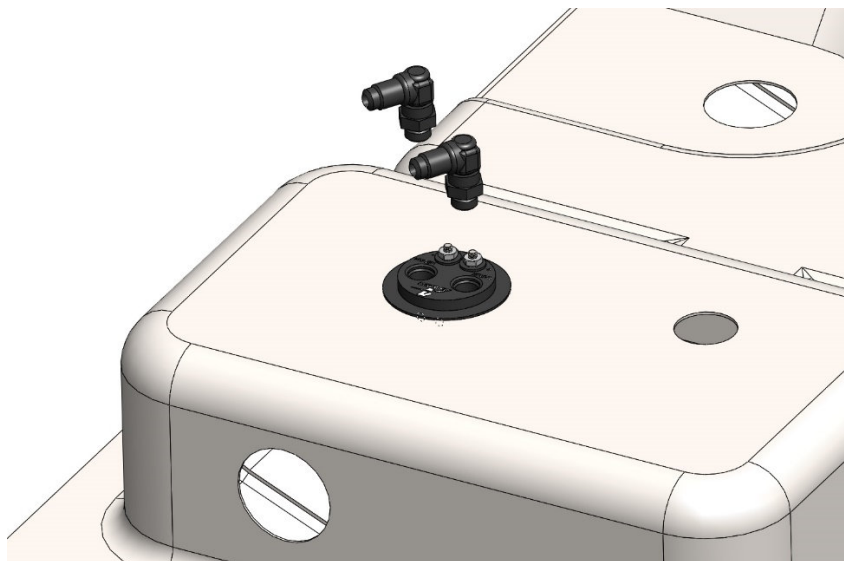

10. Connect the supply and return fuel lines to the new Aeromotive fuel pump assembly. Note: AN-08 lines will be required for carbureted applications, AN-06 or AN-08 lines may be used for EFI applications.
11. Connect the fuel pump power wires to the new Aeromotive fuel pump assembly utilizing supplied ring terminals and insulating boots.

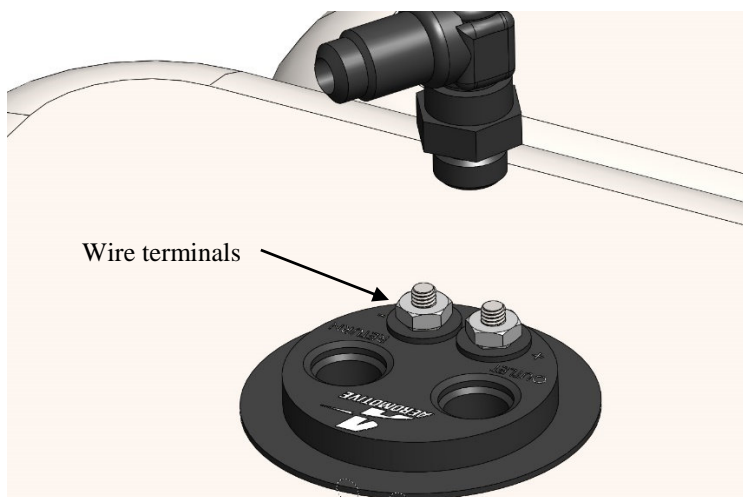

12. Position the fuel tank under the vehicle, double check that the locking ring and all fuel line and electrical connections are tight and secure. Apply a light weight oil to the filler neck grommet to ease installation.
13. As the fuel tank is lifted into position reattach the vent line to the top of the fuel tank and work the filler neck into the grommet on the side of the fuel tank. Once the fuel tank is in position, rotate the tank in the straps such that the sump is as low as possible, align the tank straps, ensure that there are not any pinched hoses or wiring, and tighten the strap bolts.

14. Make any line or electrical adjustments necessary to clear the vehicles exhaust, suspension, and drivetrain components.
15. **Ensure that any spilled gasoline and any gasoline soaked shop towels are cleaned up and removed from the vicinity of the vehicle!**
16. Carefully lower the car onto the ground.
17. Fill the fuel tank with gasoline and check for any leaks in the system, if any leaks are found repair immediately.
18. **CAUTION: While performing the following steps, if any fuel leaks are detected, immediately turn the ignition of OFF, remove any spilled fuel and repair the leak(s) before proceeding!**
19. Reconnect the battery and turn the ignition to the ON position **WITHOUT** starting the car. After several seconds, check the fuel pressure. If there is no fuel pressure, turn the ignition key to the OFF position, wait one minute, return the ignition to the ON position, and recheck the fuel pressure. Repeat this ignition OFF and ON procedure until the fuel pressure gauge registers fuel pressure.
20. **With the fuel pressure gauge registering fuel system pressure, again check for fuel leaks throughout the entire fuel system! If any fuel leaks are found, turn the ignition key to the OFF position, remove any spilled fuel and repair the leak before proceeding!**
21. Test drive the car to insure proper operation and re-check the fuel system for leaks. **If any leaks are found, immediately discontinue use of the vehicle and repair the leak(s)!**



WARNING: This product can expose you to chemicals, including chromium, which is known to the State of California to cause cancer or birth defects or other reproductive harm. For more information, visit: www.p65Warnings.ca.gov

AEROMOTIVE, INC. LIMITED WARRANTY

This Aeromotive Product, with proof of purchase dated on or after January 1, 2003, is warranted to be free from defects in materials and workmanship for a period of one year from the original date of purchase. No warranty claim will be valid without authentic, dated proof of purchase.

This warranty is to the original retail purchaser and none other and is available directly from Aeromotive and not through any point of distribution or purchase.

If a defect is suspected, the retail purchaser must contact Aeromotive directly to discuss the problem, possible solutions and obtain a Return Goods Authorization (RGA), if deemed necessary by the company. Please call 913-647-7300 and dial option 3 for the technical service dept. All returns must be shipped freight pre-paid to the company and with valid RGA before they will be processed.

Aeromotive will examine any product returned with the proper authorization to determine if the failure resulted from a defect or from abuse, improper installation, misapplication or alteration. Aeromotive will then, at it's sole discretion, return, repair or replace the product.

If any Aeromotive product is determined defective, buyer's exclusive remedy is limited in value to the sale price of the good. In no event shall Aeromotive be liable for incidental or consequential damages.

Aeromotive expressly retains the right to make changes and improvements in any product it manufactures and sells at any time. These changes and improvements may be made without notice at any time and without any obligation to change the catalogs or printed materials.

Aeromotive expressly retains the right to discontinue at any time and without notice any Aeromotive product that it manufactures or sells.

This warranty is limited and expressly limits any implied warranty to one year from the date of the original retail purchase on all Aeromotive products.

No person, party or corporate entity other than Aeromotive shall have the right to: determine whether or not this Limited Warranty is applicable to any Aeromotive product, authorize any action whatsoever under the terms and conditions of this Limited Warranty, assume any obligation or liability of any nature whatsoever on behalf of Aeromotive under the terms and conditions of this Limited Warranty.

This Limited Warranty covers only the product itself and not the cost of installation or removal.

This Limited Warranty is in lieu of and expressly excludes any and all other warranties, expressed or implied. This Limited Warranty gives you specific legal rights, and you may also have other rights which vary from state to state.