



AEROMOTIVE
Part # 18048
Replacement TVS Controller
INSTALLATION INSTRUCTIONS

This product is not legal for sale or use on emission-controlled vehicles except when used as a direct replacement part matching OEM specification.

WARNING!



Always be aware of flammable situations. Drilling and grinding can be potential ignition sources. Extinguish all open flames, prohibit smoking and eliminate all sources of ignition in the area of the vehicle and workspace before proceeding with the installation. Ensure you are working in a well ventilated area with an approved fire extinguisher nearby.

WARNING!



etc.

Installation of this product requires modification to a fuel tank/ the fuel system, failure to satisfy all safety considerations will result in fire, explosion, injury and/or loss of life to yourself and/or others. All fuel system components **MUST** be located as far from heat sources as possible, like exhaust, engine block,

WARNING!



Mechanical and hydraulic lifting devices can tip over or lower accidentally due to incorrect maneuvering or technical errors. A falling object can cause injury and/or loss of life to yourself and/or others. When working under the vehicle, always use stands, and ensure that the ground or floor is stable and level. Never crawl under a vehicle which is only supported by a jack.

WARNING!



The fuel system is under pressure. Do not open the fuel system until the pressure has been relieved. Refer to the appropriate vehicle service manual for the procedure and precautions for relieving the fuel system pressure.

CAUTION!



When installing this product always wear safety glasses and other appropriate safety apparel. A drilling operation will cause flying metal chips. Flying metal chips can cause eye injury.

CAUTION:



Installation of this product requires detailed knowledge of automotive systems and repair procedures. We recommend that this installation be carried out by a qualified automotive technician. Careless installation of this product can result in damage to the product, injury or loss of life to yourself and/or others.

Compatible Fuels:

Pump Gas
Race Gas
E85
Alcohol/Ethanol

Parts Included:

1ea Remote Controller Assembly	3ea #10-32 Hex Nuts
3ea 10-12 AWG x #10 Ring Terminals (Yellow)	4ea #10-16 Hex Head Self-Drilling Screws

This product is not legal for sale or use on emission-controlled vehicles except when used as a direct replacement part matching OEM specification.

This product is intended to be a replacement fuel pump controller on existing Aeromotive TVS brushless fuel pumps. This product is applicable to externally mounted and Stealth (in fuel cell) TVS brushless pumps. If you are trying to install a speed controller on a brush style pump, or a non-Aeromotive pump, this controller may not be compatible. Please contact the Aeromotive Tech Department for assistance.

This Remote Mount TVS brushless controller is a replacement or upgrade for installation and use only on Aeromotive brushless pumps that were originally offered with an optional, factory installed TVS controller.

Non-TVS Brushless A1000 and Eliminator products manufactured prior to 02/01/2020 are not compatible with this replacement TVS brushless controller. In this case use the Non-TVS replacement brushless controller, Aeromotive p/n 18027.

The following steps are typical of most installations:

1. Once the engine has been allowed to cool, relieve the fuel system pressure and disconnect power (and control signal, as applicable) to the pump.
2. **If replacing a pump with an integrated controller cap**, disconnect the line from the pump outlet and remove the ORB-10 outlet fitting. No other lines need to be disconnected to complete the replacement.

CAUTION: Ensure that any spilled fuel and any fuel-soaked shop towels are cleaned up and removed from the vicinity of the vehicle before proceeding.

3. Pumps with Integral Controller Cap:

Remove the two #8-32 hex-head cap screws securing the controller to the pump and lift the motor controller off the pump outlet end cap.

Pumps with Remote-Mounted Controller:

Remove the four #10-16 hex-head screws for mounting the controller assembly.

4. Disconnect the three controller-to-motor lead wires from the pump outlet end cap being sure to note the wire color to terminal locations. Note: the pump outlet endcap may not be marked. (hint: take a picture before removing wires).

IF REPLACING A REMOTE-MOUNTED CONTROLLER, SKIP TO STEP 6.

5. Determine a suitable location to mount the new controller remote from the pump considering the following:

- a) It is recommended to keep the controller-to-motor lead wire lengths as short as possible for best pump performance.
- b) If desired, motor lead wires may be extended but should be kept as short as possible and lead extensions should be sized large to keep electrical resistance low (10-gauge or larger, high quality, Mil-Spec wire is recommended. Mil-Spec wire is available from industrial suppliers like McMaster Carr, Grainger, etc. for example).
- c) The controller is fully sealed so it can be mounted externally (frame rail, e.g.). The controller heat-sink is designed to be able to handle low air flow so it can also be mounted internally (trunk, e.g.). However, for best results, it is recommended to mount the controller such that it will receive the most and coolest air flow.

When mounting the controller externally and in a location that will likely receive air flow from driving, mount the controller with fins parallel to the airflow and, if possible, upward (not required with sufficient air flow) as in the following image.

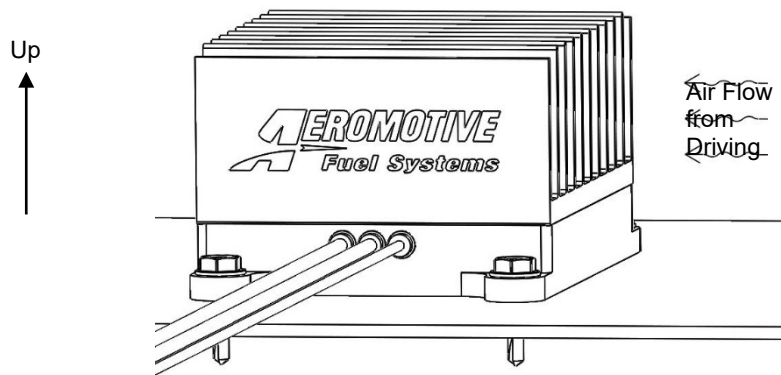

When mounting the controller internally or behind obstructions in a location that will not receive much air flow from driving, mount the controller with the fins vertically as in the following image to achieve the maximum natural convective cooling.

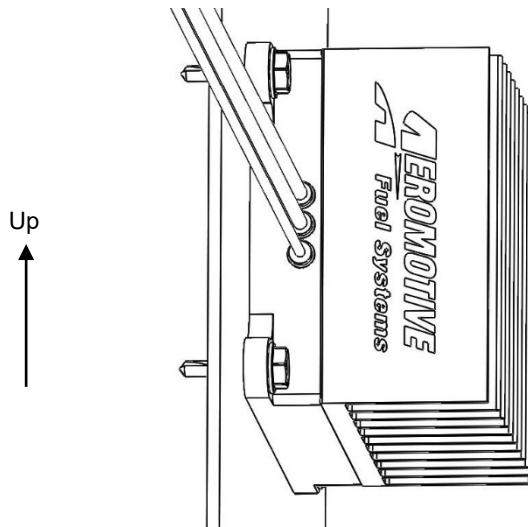

d) **NOTE: THIS CONTROLLER CAN GET HOT** when using full power (60A) continuously with little air flow. **Mount away from locations prone to fuel vapor (e.g., tank vent).**

6. Once a suitable location is found, mount the controller in the recommended orientation using the four #10 self-drilling screws.
7. Crimp the #10 ring terminals to the red/gray/black motor lead wires after cutting to length if not using extensions.
8. Connect the three motor leads from the new controller to the pump matching the colors to the previous wire locations (In most cases, the black lead connects to the "B", red to "R", and white or gray to "W"). Secure connections using the #10-32 nuts, firmly holding the terminal end in place while tightening.
9. Replace the ORB-10 outlet fitting removed in Step 2 (as applicable) and reconnect the line to the pump outlet.

CAUTION: Ensure that any spilled fuel and any fuel-soaked shop towels are cleaned up and removed from the vicinity of the vehicle before proceeding.

10. Reconnect power and ground to the new pump controller, +12-16 VDC to the red lead, Ground to the black lead.
NOTE: POWER TO THE PUMP MUST BE FLAT DC, NOT PULSE WIDTH MODULATED!

CAUTION: DO NOT REVERSE THE POLARITY - CONNECT AS ABOVE, red to power black to ground. Reversing the polarity will render the controller inoperable and will void all warranties for this product!

11. This pump controller allows the ability to change the speed of the pump via a 0-5VDC analog input to the yellow signal wire. **THE CONTROL SIGNAL MUST BE A TRUE ANALOG INPUT, NOT PWM.** A PWM signal can only be used if filtered sufficiently for smooth/flat output. The signal wire used to control the speed of the pump may be connected in ONE of multiple configuration examples as shown in the following illustrations to control the speed of the pump.
12. This pump controller has a minimum floor for pump speed of approximately 40% depending on the pump. This means that fuel pump speed will not fall below 40% of full speed with zero input voltage on the yellow control signal wire.
13. This pump controller has a minimum voltage threshold (floor) of approximately 0.5VDC. Voltage above 0.5VDC on the yellow input wire will increase the speed of the pump. Signal input of voltage below 0.5VDC will have no effect on pump speed. This ensures allowance for minimum, closed throttle TPS settings of up to 0.5VDC without affecting fuel pump speed at idle.
14. This pump controller has a full pump speed voltage threshold (ceiling) of approximately 3.7VDC, where the full pump speed will be achieved with signal input voltage at or above 3.7VDC. Voltage above 3.7VDC will not result in any further increase in pump speed. This ensures that when a TPS signal is used to drive pump speed that typical throttle openings of 70-75% and higher will ensure full fuel pump volume is delivered to the fuel rail or carburetor. Voltage between 0.5VDC and 3.7VDC will vary the speed of the fuel pump according to the voltage applied.

CONTROL CONFIGURATIONS:

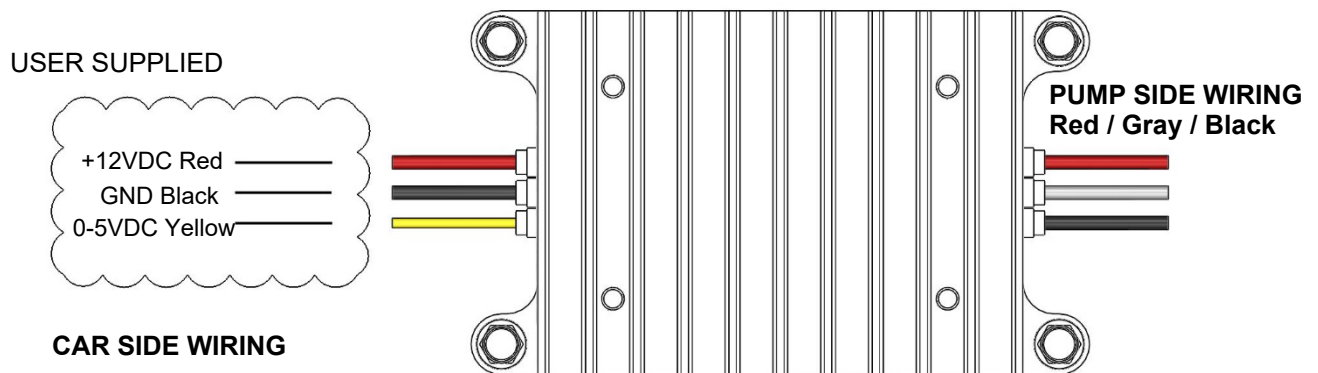

MODE 1 – TPS or Other 0-5VDC Input Control

Aeromotive recommends the “Mode 1” control method where the 0-5VDC signal input is tied to a Throttle Position Sensor using the output wire to the ECU. The intent for this control is to reduce the fuel pump output (and thus the amount of fuel returned to the tank) during low throttle opening (low engine demand) to reduce excess recycling of fuel to help keep fuel tank temperatures low. Alternatively, other 0-5VDC analog output sensors (some MAF sensors, a 2 or 3-Bar MAP sensor, etc.) or voltage dividing/regulating/switching components may be used. It is the customer’s responsibility to ensure a signal supply and control strategy where the fuel flow is sufficient to meet engine demand.

If no signal supply is suitable or desired, the controller can still be wired for use as in Modes 2 – 4, as shown following, to allow different fuel pump speed and flow outputs from the pump.

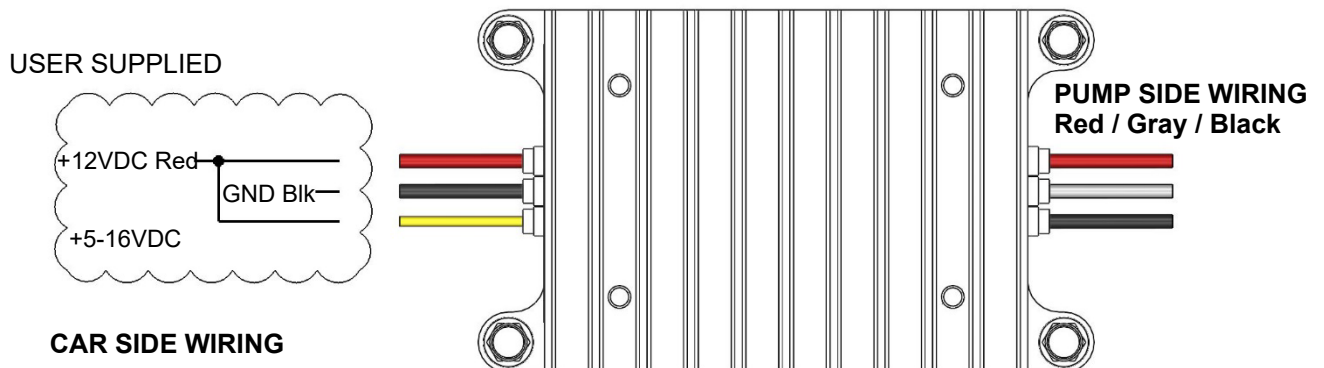

MODE 2 – Constant Full Speed

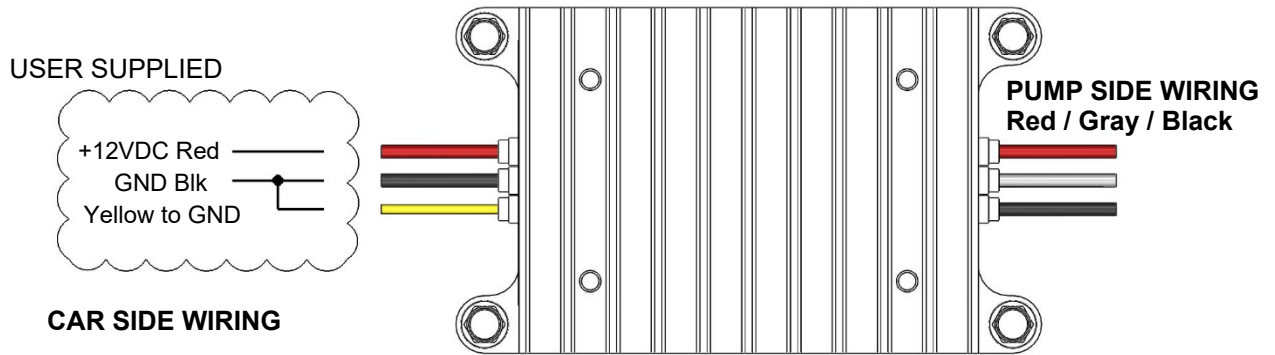

MODE 3 – Constant Low Speed

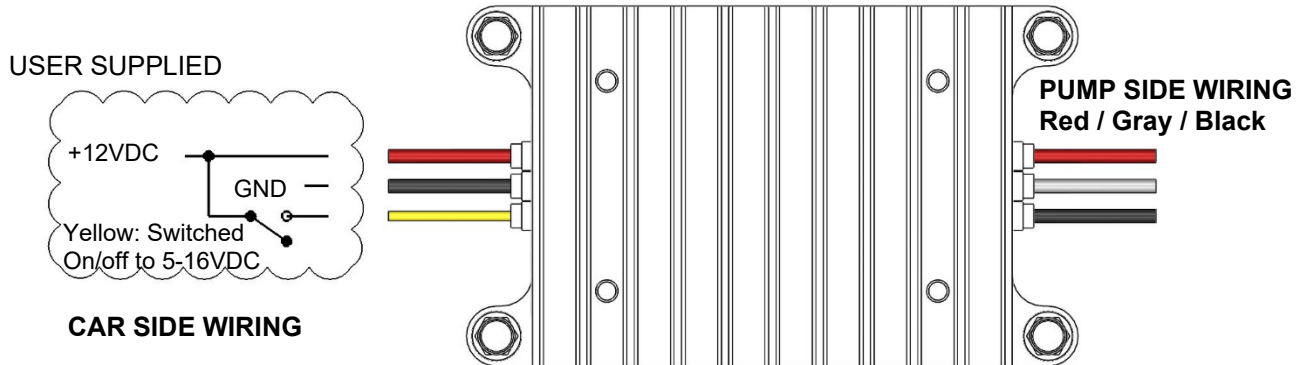

MODE 4 – Switched Speed “On – Demand”, from Low to High

Mode 4 can be activated by any relay or switch providing 5VDC or higher (system voltage up to 19VDC is fine) to the control wire. A relay for this purpose could be activated using the programmable output from a tunable ECU, or via a boost Hobb's or WOT switch connected to 12VDC to name a few examples.

15. After all wire connections are made, attach a suitable fuel pressure gauge to the fuel system Schrader valve, fuel rail or fuel pressure regulator test port. Examples:

Aeromotive P/N **15632** 0-15 PSI (1 1/2") Fuel Pressure Gauge
Aeromotive P/N **15633** 0-100 PSI (1 1/2") Fuel Pressure Gauge

Ensure that any spilled fuel and any fuel-soaked shop towels are cleaned up and removed from the vicinity of the vehicle.

CAUTION: While performing the following steps, if any fuel leaks are detected, immediately turn the ignition to OFF, remove any spilled fuel and repair the leak(s) before proceeding!

16. Turn the ignition to ON **without starting the engine**, allow the pump to run for several seconds and check the fuel pressure. If there is no pressure, turn the ignition to OFF, wait one minute, then turn the ignition to ON and recheck the pressure. Repeat this ignition OFF and ON procedure until the gauge registers pressure or you detect a fuel leak. If no pressure is registered on the gauge after running the pump for several seconds and you have found no leaks, check all fuel and electrical connections to determine the cause. **IF THE PUMP IS RUNNING BACKWARDS, REPEAT THE ABOVE STEPS SWITCHING ANY OF THE TWO MOTOR LEAD WIRES FROM STEP 8**, then reconnect and retest the pump.

CAUTION: DO NOT REVERSE THE TWO POWER LEADS EXTERNAL TO THE CAP! Reversing the polarity of the main power and ground wires going into the controller will render the controller inoperable and will void all warranties for this product!

17. Once the fuel pressure gauge registers pressure, start the engine. If you have installed an adjustable fuel pressure regulator, switch the pump to full speed and adjust base fuel pressure to the desired setting.

18. Test-drive the vehicle to insure proper operation and re-check the fuel system for leaks. If any leaks are found, immediately discontinue use of the vehicle and repair the leak(s)!

Contact Us

RGA NUMBER REQUIRED FOR ALL RETURNS TO AEROMOTIVE.

To obtain an RGA number, please call (913) 647-7300 and ask for the Returns and Repairs department or complete the online form under the "Rebuilds" section at www.aeromotiveinc.com.

- **Shipping & Returns**

Aeromotive Inc.
10955 Mill Creek Road
Lenexa, KS 66219

General Inquiries and Tech Line: (913) 647-7300

General Email: info@aeromotiveinc.com

Tech Email: tech@aeromotiveinc.com

The Aeromotive Tech Lines are open Monday through Friday from 9:30AM to 5:00PM Central Standard Time.



WARNING: This product can expose you to chemicals, including chromium, which is known to the State of California to cause cancer or birth defects or other reproductive harm. For more information, visit: www.p65Warnings.ca.gov

AEROMOTIVE, INC. LIMITED WARRANTY

This Aeromotive Product, with proof of purchase dated on or after January 1, 2003, is warranted to be free from defects in materials and workmanship for a period of one year from the original date of purchase. No warranty claim will be valid without authentic, dated proof of purchase.

This warranty is to the original retail purchaser and none other and is available directly from Aeromotive and not through any point of distribution or purchase.

If a defect is suspected, the retail purchaser must contact Aeromotive directly to discuss the problem, possible solutions and obtain a Return Goods Authorization (RGA), if deemed necessary by the company. Please call 913-647-7300 and dial option 3 for the technical service dept. All returns must be shipped freight pre-paid to the company and with valid RGA before they will be processed.

Aeromotive will examine any product returned with the proper authorization to determine if the failure resulted from a defect or from abuse, improper installation, misapplication or alteration. Aeromotive will then, at it's sole discretion, return, repair or replace the product.

If any Aeromotive product is determined defective, buyer's exclusive remedy is limited in value to the sale price of the good. In no event shall Aeromotive be liable for incidental or consequential damages.

Aeromotive expressly retains the right to make changes and improvements in any product it manufactures and sells at any time. These changes and improvements may be made without notice at any time and without any obligation to change the catalogs or printed materials.

Aeromotive expressly retains the right to discontinue at any time and without notice any Aeromotive product that it manufactures or sells.

This warranty is limited and expressly limits any implied warranty to one year from the date of the original retail purchase on all Aeromotive products.

No person, party or corporate entity other than Aeromotive shall have the right to: determine whether or not this Limited Warranty is applicable to any Aeromotive product, authorize any action whatsoever under the terms and conditions of this Limited Warranty, assume any obligation or liability of any nature whatsoever on behalf of Aeromotive under the terms and conditions of this Limited Warranty.

This Limited Warranty covers only the product itself and not the cost of installation or removal.

This Limited Warranty is in lieu of and expressly excludes any and all other warranties, expressed or implied. This Limited Warranty gives you specific legal rights, and you may also have other rights which vary from state to state.