



AEROMOTIVE
Part # 16301
INSTALLATION INSTRUCTIONS

This product is not legal for sale or use on emission-controlled vehicles except when used as a direct replacement part matching OEM specification.

WARNING!



Always be aware of flammable situations. Drilling and grinding can be potential ignition sources. Extinguish all open flames, prohibit smoking and eliminate all sources of ignition in the area of the vehicle and workspace before proceeding with the installation. Ensure you are working in a well ventilated area with an approved fire extinguisher nearby.

WARNING!



etc.

Installation of this product requires modification to a fuel tank/ the fuel system, failure to satisfy all safety considerations will result in fire, explosion, injury and/or loss of life to yourself and/or others. All fuel system components **MUST** be located as far from heat sources as possible, like exhaust, engine block,

WARNING!



Mechanical and hydraulic lifting devices can tip over or lower accidentally due to incorrect maneuvering or technical errors. A falling object can cause injury and/or loss of life to yourself and/or others. When working under the vehicle, always use stands, and ensure that the ground or floor is stable and level. Never crawl under a vehicle which is only supported by a jack.

WARNING!



The fuel system is under pressure. Do not open the fuel system until the pressure has been relieved. Refer to the appropriate vehicle service manual for the procedure and precautions for relieving the fuel system pressure.

CAUTION!



When installing this product always wear safety glasses and other appropriate safety apparel. A drilling operation will cause flying metal chips. Flying metal chips can cause eye injury.

CAUTION:



Installation of this product requires detailed knowledge of automotive systems and repair procedures. We recommend that this installation be carried out by a qualified automotive technician. Careless installation of this product can result in damage to the product, injury or loss of life to yourself and/or others.

Compatible Fuels:

Pump Gas
Race Gas
E85
Alcohol/Ethanol

Parts Included:

1ea 30 Amp 12 VDC Automotive Relay
1ea 30 Amp 12 VDC Circuit Breaker
2ea Blue Female Blade Connector
2ea Yellow Female Blade Connector
5ea Yellow Ring Connector for #10 Stud
1ea Yellow Ring Connector for 3/8" Stud
25ft 10ga. Red Wire
3ft 10ga. Black Wire
6ea 6 inch cable ties

Tools / Supplies Needed:

Electrical terminal crimping tool
3/8" Wrench

1. Once the engine has been allowed to cool, disconnect the negative battery cable.
2. Raise the vehicle and support it with jack stands.
3. Find a suitable place to mount the supplied relay. If this is an installation on an OEM vehicle the relay is typically mounted by the OEM fuel pump wiring connector (***Never mount the relay inside of the fuel tank or next to fuel tank vents!***). Insure the relay and any associated parts are clear of the exhaust, any moving suspension or drivetrain components and any possible road obstructions or debris.
4. Attach the OEM fuel pump wires, the aftermarket ECM fuel pump wires or your fuel pump switch wires to relay terminals 85 and 86 using two of the supplied blue female blade connectors (See Diagram Below).

Note: Be sure to route all electrical wires clear of any moving suspension or drivetrain components, and any exhaust components! Protect wires from abrasion and road obstructions or debris.

5. Find a suitable location for mounting the supplied circuit breaker. For optimal circuit protection, the circuit breaker needs to be mounted as close to the battery as possible.
6. Connect terminal number 30 on the relay to the circuit breaker by using the supplied red 10 ga. wire, one of the yellow female blade connectors on the relay end of the wire and one of the yellow #10 ring connectors on the circuit breaker side of the wire.

Note: Be sure to route all electrical wires clear of any moving suspension or drivetrain components and any exhaust components! Protect wires from abrasion and road obstructions or debris.

7. Connect terminal number 87 on the relay to the positive terminal on the fuel pump. This is accomplished by using the supplied red 10 ga wire, one of the yellow female blade connectors on the relay side of the wire and one of the yellow #10 ring connectors (or appropriate connector for the installation) on the fuel pump side of the wire.
8. Connect the negative terminal on the fuel pump to a clean chassis ground using the supplied black 10 ga wire and two yellow #10 ring connectors.

9. Connect 12VDC to the circuit breaker using the supplied red wire and one of the yellow #10 ring connectors and the supplied yellow 3/8" ring connector.
10. Ensure that electrical components and wires are connected properly (See Diagram Below) and are clear of any moving suspension or drivetrain components and any exhaust components! Protect wires from abrasion and road obstructions or debris.

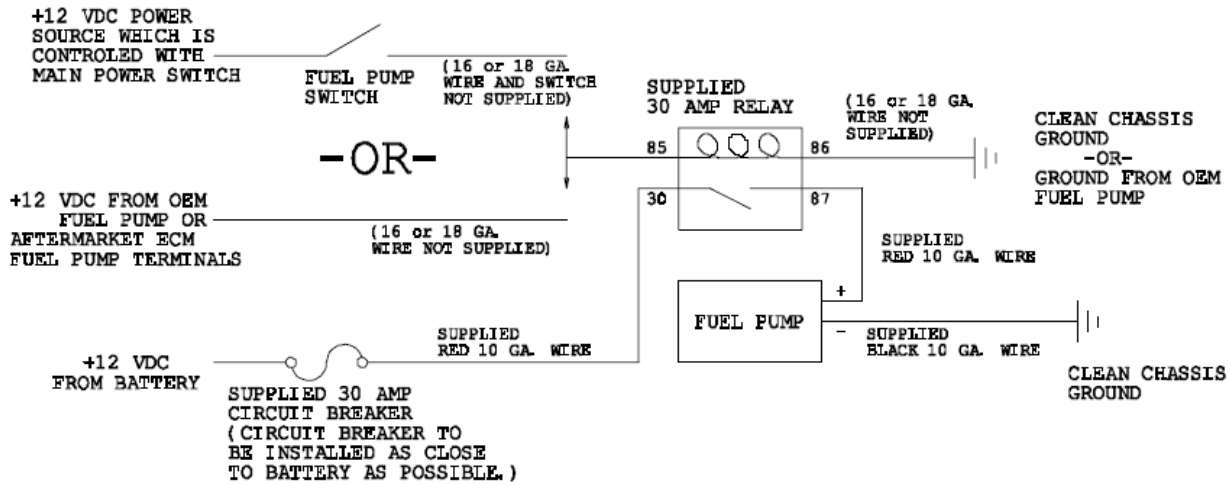

11. Carefully lower the car onto the ground and reconnect the negative battery terminal.
12. Test the vehicle for proper fuel pump operation.

Contact Us

RGA NUMBER REQUIRED FOR ALL RETURNS TO AEROMOTIVE.

To obtain an RGA number, please call (913) 647-7300 and ask for the Returns and Repairs department or complete the online form under the "Rebuilds" section at www.aeromotiveinc.com.

- **Shipping & Returns**

Aeromotive Inc.
10955 Mill Creek Road
Lenexa, KS 66219

General Inquiries and Tech Line: (913) 647-7300

General Email: info@aeromotiveinc.com

Tech Email: tech@aeromotiveinc.com

The Aeromotive Tech Lines are open Monday through Friday from 9:30AM to 5:00PM Central Standard Time.



WARNING: This product can expose you to chemicals, including chromium, which is known to the State of California to cause cancer or birth defects or other reproductive harm. For more information, visit: www.p65Warnings.ca.gov

AEROMOTIVE, INC. LIMITED WARRANTY

This Aeromotive Product, with proof of purchase dated on or after January 1, 2003, is warranted to be free from defects in materials and workmanship for a period of one year from the original date of purchase. No warranty claim will be valid without authentic, dated proof of purchase.

This warranty is to the original retail purchaser and none other and is available directly from Aeromotive and not through any point of distribution or purchase.

If a defect is suspected, the retail purchaser must contact Aeromotive directly to discuss the problem, possible solutions and obtain a Return Goods Authorization (RGA), if deemed necessary by the company. Please call 913-647-7300 and dial option 3 for the technical service dept. All returns must be shipped freight pre-paid to the company and with valid RGA before they will be processed.

Aeromotive will examine any product returned with the proper authorization to determine if the failure resulted from a defect or from abuse, improper installation, misapplication or alteration. Aeromotive will then, at it's sole discretion, return, repair or replace the product.

If any Aeromotive product is determined defective, buyer's exclusive remedy is limited in value to the sale price of the good. In no event shall Aeromotive be liable for incidental or consequential damages.

Aeromotive expressly retains the right to make changes and improvements in any product it manufactures and sells at any time. These changes and improvements may be made without notice at any time and without any obligation to change the catalogs or printed materials.

Aeromotive expressly retains the right to discontinue at any time and without notice any Aeromotive product that it manufactures or sells.

This warranty is limited and expressly limits any implied warranty to one year from the date of the original retail purchase on all Aeromotive products.

No person, party or corporate entity other than Aeromotive shall have the right to: determine whether or not this Limited Warranty is applicable to any Aeromotive product, authorize any action whatsoever under the terms and conditions of this Limited Warranty, assume any obligation or liability of any nature whatsoever on behalf of Aeromotive under the terms and conditions of this Limited Warranty.

This Limited Warranty covers only the product itself and not the cost of installation or removal.

This Limited Warranty is in lieu of and expressly excludes any and all other warranties, expressed or implied. This Limited Warranty gives you specific legal rights, and you may also have other rights which vary from state to state.