



AEROMOTIVE
Part # 14147
Fits Edelbrock 29085 LS1 Intake
INSTALLATION INSTRUCTIONS

This product is not legal for sale or use on emission-controlled vehicles except when used as a direct replacement part matching OEM specification.

WARNING!



Always be aware of flammable situations. Drilling and grinding can be potential ignition sources. Extinguish all open flames, prohibit smoking and eliminate all sources of ignition in the area of the vehicle and workspace before proceeding with the installation. Ensure you are working in a well ventilated area with an approved fire extinguisher nearby.

WARNING!



etc.

Installation of this product requires modification to a fuel tank/ the fuel system, failure to satisfy all safety considerations will result in fire, explosion, injury and/or loss of life to yourself and/or others. All fuel system components **MUST** be located as far from heat sources as possible, like exhaust, engine block,

WARNING!



Mechanical and hydraulic lifting devices can tip over or lower accidentally due to incorrect maneuvering or technical errors. A falling object can cause injury and/or loss of life to yourself and/or others. When working under the vehicle, always use stands, and ensure that the ground or floor is stable and level. Never crawl under a vehicle which is only supported by a jack.

WARNING!



The fuel system is under pressure. Do not open the fuel system until the pressure has been relieved. Refer to the appropriate vehicle service manual for the procedure and precautions for relieving the fuel system pressure.

CAUTION!



When installing this product always wear safety glasses and other appropriate safety apparel. A drilling operation will cause flying metal chips. Flying metal chips can cause eye injury.

CAUTION:



Installation of this product requires detailed knowledge of automotive systems and repair procedures. We recommend that this installation be carried out by a qualified automotive technician. Careless installation of this product can result in damage to the product, injury or loss of life to yourself and/or others.

Compatible Fuels:

Pump Gas
Race Gas
E85
Alcohol/Ethanol

Parts Included:

2ea 14147 Fuel Rails for Edelbrock 29085 LS1 Intake
4ea 1/4-20 x 1/2" Flange Head Mounting Bolts

The enclosed Aeromotive fuel rails utilize o-ring sealed AN-08 style ports; these ports are **NOT PIPE THREAD** and utilize **NO THREAD SEALANT**. To use the enclosed fuel rails in your vehicle's fuel system you must install the necessary adapter fittings and o-rings, high pressure fuel lines and regulator to adapt your system to the configuration and ports of these fuel rails. Please call for a catalog of the complete line of quality Aeromotive products.

The enclosed Aeromotive fuel rails are intended to be installed on an unmodified intake manifold of the identified application. Aeromotive cannot guarantee the proper fitment on modified intake manifolds and the end user is responsible for verifying proper fitment and assumes all liability.

When installing o-rings it is important to place a small amount of light oil on both the o-ring and the mating surface to ease installation and prevent damaging the o-ring.

The following installation instructions are for a typical installation, for specific year and model installation instructions please refer to your vehicles service manual.

Aeromotive system components are not legal for sale or use on emission controlled motor vehicles.

The following steps are typical of most installations:

1. Once the engine has been allowed to cool, disconnect the negative battery cable and relieve fuel system pressure, referring to the appropriate vehicle service manual for the procedure on doing so.
2. Check for any dirt or debris around the fuel injectors. If any is evident, wash it off with some solvent parts cleaner or wipe it off with a clean shop towel.
3. Disconnect the electrical connector at each injector, making note of the location of each.
4. Disconnect both the supply and return fuel lines from the fuel rails. Place clean shop towels around the open fuel lines to catch any gasoline that may drip out and to prevent any dirt from entering the fuel lines.

Failure to satisfy all safety considerations will result in fire, explosion, injury and/or loss of life to yourself and/or others.

5. Remove the vacuum line from the fuel pressure regulator.
6. Remove the mounting bolts that attach the fuel rails to the intake manifold.
7. Place clean shop towels around the injectors to catch any gasoline that may be spilled during their removal. Remove the injectors from the manifold by gently pulling upward on the fuel rail / injector assembly. Keep all injectors connected to the fuel rails. If an injector does pull out of the fuel rail, it may spill a large amount of fuel.

Failure to satisfy all safety considerations will result in fire, explosion, injury and/or loss of life to yourself and/or others.

8. Carefully remove the fuel injectors from the fuel rails you are replacing.
9. Remove the old o-rings from the fuel injectors, inspect the injectors for any dirt or debris and clean if needed. It is suggested that the old o-rings be replaced, contact your local parts store or dealer to purchase the correct replacement o-rings.
10. Coat the new fuel injector o-rings with a light oil to ease installation.
11. Carefully install the new fuel injector o-rings on the injectors.

When installing o-rings it is important to place a small amount of light oil on both the o-ring and the mating surface to ease installation and prevent damaging the o-ring.

12. Install the appropriate ORB-08 o-ring port fittings, with o-rings on each fuel rail, we recommend Aeromotive p/n 15605 for AN-06 fuel line connections or Aeromotive p/n 15607 for AN-08.
13. Place a thin coat of light oil in the fuel rail fuel injector bores and in the lower intake manifold injector bores to help prevent cutting the o-rings during installation.
14. Carefully place each of the fuel injectors in the corresponding fuel injector bore of the Aeromotive fuel rail.
15. After insuring that the injectors are properly seated in the intake manifold injector bores, reinstall the fuel rail mounting bolts.
16. With the Aeromotive fuel rail properly secured to the intake manifold, Move the fuel injector vertically downward until it bottoms out on the intake manifold, In this downward position, inspect the upper fuel injector o-ring (on the fuel rail side) and insure it is fully covered by the fuel rail injector bore. If any of the o-ring is exposed, loosen the fuel rail bracket screws and adjust the installation height until the o-ring is no longer exposed and retighten the bracket screws. In the situation where the fuel injector has no vertical travel, either the fuel rail brackets can be adjusted or the brackets shimmed until the fuel injector fits freely. Do not pressurize the fuel rail until the proper fuel rail installation height is achieved.
17. Plumb the remainder of the fuel system with high pressure AN fuel lines and fittings. Aeromotive recommends an after-market fuel pressure regulator such as Aeromotive p/n 13101 or 13109 (If you are converting the fuel system to a return style system).

Figure 1-1 depicts a fuel rail with only one fuel line connection, such as is commonly found on OEM factory fuel rails in late model "returnless" fuel systems beginning in 1999. Positioning the regulator after the fuel rail is optimum for performance applications, however an Aeromotive return style regulator may be configured for a "returnless" type of engine/fuel rail assembly. Connect the fuel supply line from the pump into one of the regulator side ports, then exit out of the opposite side port and into the fuel rail. A Quick Connect to AN adapter may be required to connect to the OEM fuel rail, and a return line must be routed from from the regulator bottom/return port back to the top of the tank.

Examples of return style fuel system plumbing

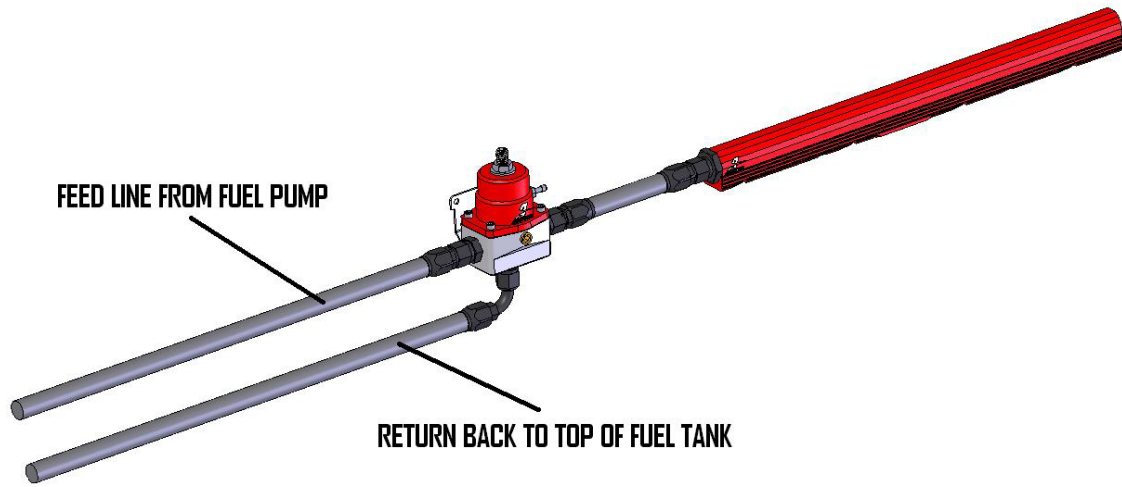

FIGURE 1-1

Figure 1-2 shows the optimum fuel rail plumbing for performanc V8 engines with duel fuel rails, including a Y-block to feed the fuel rails and the return style regulator located in the cross-over on the other end, with return line.

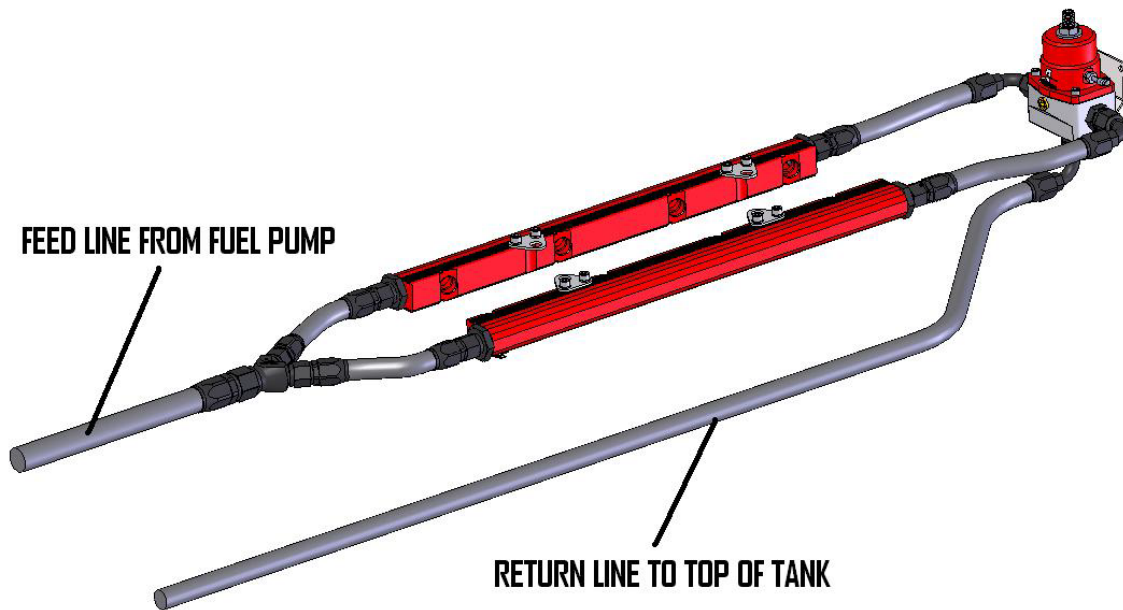

FIGURE 1-2

Example of "returnless" fuel system plumbing

Figure 1-3 shows plumbing for a typical "returnless" system where the OEM fuel pump and regulator assembly are located in the tank.



FIGURE 1-3

Ensure that any spilled gasoline and any gasoline soaked shop towels are cleaned up and removed from the vicinity of the vehicle!

18. Reconnect the battery and turn the ignition to the ON position **WITHOUT** starting the car. After several seconds, check the fuel pressure. If there is no fuel pressure, turn the ignition key to the OFF position, wait one minute, return the ignition to the ON position, and recheck the fuel pressure. Repeat this ignition OFF and ON procedure until the fuel pressure gauge registers fuel pressure.
19. **With the fuel pressure gauge registering fuel system pressure, check for fuel leaks from and around all the fuel system components and all fuel lines and connections! If any fuel leaks are found, turn the ignition key to the OFF position, remove any spilled fuel and repair the leak before proceeding!**
20. Once the fuel pressure gauge registers fuel system pressure and there are no fuel leaks, start the engine and adjust the regulator to the desired fuel pressure.
21. Once the desired fuel pressure is achieved, tighten the regulator adjustment jam nut and attach the vacuum line.
22. Turn off the engine and allow it to cool.
23. Test drive the car to insure proper operation and re-check the fuel system for leaks. **If any leaks are found, immediately shutoff the engine and repair the leak(s)!**

Contact Us

RGA NUMBER REQUIRED FOR ALL RETURNS TO AEROMOTIVE.

To obtain an RGA number, please call (913) 647-7300 and ask for the Returns and Repairs department or complete the online form under the "Rebuilds" section at www.aeromotiveinc.com.

- **Shipping & Returns**

Aeromotive Inc.
10955 Mill Creek Road
Lenexa, KS 66219

General Inquiries and Tech Line: (913) 647-7300

General Email: info@aeromotiveinc.com

Tech Email: tech@aeromotiveinc.com

The Aeromotive Tech Lines are open Monday through Friday from 9:30AM to 5:00PM Central Standard Time.



WARNING: This product can expose you to chemicals, including chromium, which is known to the State of California to cause cancer or birth defects or other reproductive harm. For more information, visit: www.p65Warnings.ca.gov

AEROMOTIVE, INC. LIMITED WARRANTY

This Aeromotive Product, with proof of purchase dated on or after January 1, 2003, is warranted to be free from defects in materials and workmanship for a period of one year from the original date of purchase. No warranty claim will be valid without authentic, dated proof of purchase.

This warranty is to the original retail purchaser and none other and is available directly from Aeromotive and not through any point of distribution or purchase.

If a defect is suspected, the retail purchaser must contact Aeromotive directly to discuss the problem, possible solutions and obtain a Return Goods Authorization (RGA), if deemed necessary by the company. Please call 913-647-7300 and dial option 3 for the technical service dept. All returns must be shipped freight pre-paid to the company and with valid RGA before they will be processed.

Aeromotive will examine any product returned with the proper authorization to determine if the failure resulted from a defect or from abuse, improper installation, misapplication or alteration. Aeromotive will then, at it's sole discretion, return, repair or replace the product.

If any Aeromotive product is determined defective, buyer's exclusive remedy is limited in value to the sale price of the good. In no event shall Aeromotive be liable for incidental or consequential damages.

Aeromotive expressly retains the right to make changes and improvements in any product it manufactures and sells at any time. These changes and improvements may be made without notice at any time and without any obligation to change the catalogs or printed materials.

Aeromotive expressly retains the right to discontinue at any time and without notice any Aeromotive product that it manufactures or sells.

This warranty is limited and expressly limits any implied warranty to one year from the date of the original retail purchase on all Aeromotive products.

No person, party or corporate entity other than Aeromotive shall have the right to: determine whether or not this Limited Warranty is applicable to any Aeromotive product, authorize any action whatsoever under the terms and conditions of this Limited Warranty, assume any obligation or liability of any nature whatsoever on behalf of Aeromotive under the terms and conditions of this Limited Warranty.

This Limited Warranty covers only the product itself and not the cost of installation or removal.

This Limited Warranty is in lieu of and expressly excludes any and all other warranties, expressed or implied. This Limited Warranty gives you specific legal rights, and you may also have other rights which vary from state to state.