



AEROMOTIVE
Part # 13301 & 13351
INSTALLATION INSTRUCTIONS

This product is not legal for sale or use on emission-controlled vehicles except when used as a direct replacement part matching OEM specification.

WARNING!



Always be aware of flammable situations. Drilling and grinding can be potential ignition sources. Extinguish all open flames, prohibit smoking and eliminate all sources of ignition in the area of the vehicle and workspace before proceeding with the installation. Ensure you are working in a well ventilated area with an approved fire extinguisher nearby.

WARNING!



etc.

Installation of this product requires modification to a fuel tank/ the fuel system, failure to satisfy all safety considerations will result in fire, explosion, injury and/or loss of life to yourself and/or others. All fuel system components **MUST** be located as far from heat sources as possible, like exhaust, engine block,

WARNING!



Mechanical and hydraulic lifting devices can tip over or lower accidentally due to incorrect maneuvering or technical errors. A falling object can cause injury and/or loss of life to yourself and/or others. When working under the vehicle, always use stands, and ensure that the ground or floor is stable and level. Never crawl under a vehicle which is only supported by a jack.

WARNING!



The fuel system is under pressure. Do not open the fuel system until the pressure has been relieved. Refer to the appropriate vehicle service manual for the procedure and precautions for relieving the fuel system pressure.

CAUTION!



When installing this product always wear safety glasses and other appropriate safety apparel. A drilling operation will cause flying metal chips. Flying metal chips can cause eye injury.

CAUTION:



Installation of this product requires detailed knowledge of automotive systems and repair procedures. We recommend that this installation be carried out by a qualified automotive technician. Careless installation of this product can result in damage to the product, injury or loss of life to yourself and/or others.

Compatible Fuels:

Pump Gas
Race Gas
E85
Alcohol/Ethanol
Diesel

The enclosed Aeromotive regulator utilizes four 3/8 NPT pipe thread inlet/outlet ports and one 3/8-NPT pipe thread return/bypass port. In order to use the enclosed regulator in your vehicle's fuel system, you must install the necessary adapter fittings, high pressure fuel lines and/or fuel injector rails to adapt your system to the configuration and ports of this regulator. The following instructions assume that your fuel system has already been configured for use with this regulator.

Aeromotive system components are not legal for sale or use on emission controlled motor vehicles.

Performance Specifications: Model 13301

Outlet Fuel Pressure, adjustable	3-20 psi low pressure spring (installed from factory)
	20-65 psi high pressure spring
Max Pump Flow Rate	250 GPH
Inlet / Outlet ports	4ea. 3/8-NPT
Bypass port (located at bottom of regulator)	1ea. 3/8-NPT
Fuel Compatibility	Pump gas, race gas, E85, Alcohol/Ethanol, and Diesel

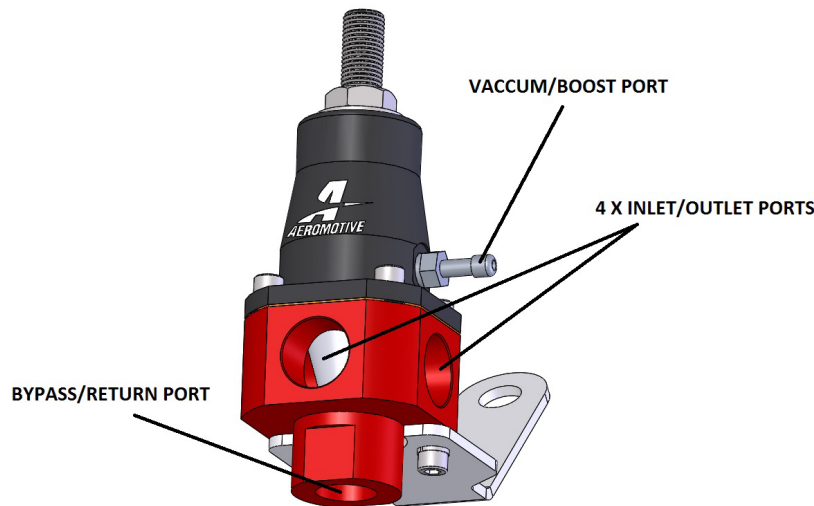

The following steps are typical of most installations:

1. Once the engine has been allowed to cool, disconnect the negative battery cable and relieve the fuel system pressure.
2. Remove any cosmetic covers necessary to allow access to the fuel pressure regulator.
3. Remove the vacuum line from the regulator.
4. Place shop towels around the regulator to catch any gasoline that is spilled during this step of the installation. Remove any regulator mounting hardware and connecting fuel lines, then carefully remove the regulator.
5. Find a suitable place in the vehicle's engine compartment to mount the Aeromotive regulator. Using the supplied mounting bracket as a template, mark the bracket mounting hole and drill to accept mounting bolt.

6. Determine approximate fuel pressure your system will require. If your fuel pressure requirement is between 3 and 20 psi, the factory installed regulator spring is the proper spring. If your fuel pressure requirement is between 20 and 65 psi, insure the pressure adjustment set screw is backed out all the way, remove the 4 cover screws and cover, remove the factory installed spring, replace it with the high pressure spring, and reassemble the regulator.
7. With the bracket attached to the regulator, mount the regulator to the vehicle.
8. Attach the fuel supply line(s) to the regulator using any of the 3/8-NPT ports located around the perimeter of the regulator. Now choose any of the three remaining perimeter ports as the outlet. Install 3/8-NPT pipe plugs into any of the unused regulator inlet/outlet ports. A 3/8" NPT to 1/8" NPT bushing may be installed in any unused port around the top to connect a fuel pressure gauge if desired. **Please note that these ports are pipe threads and will require the use of a pipe thread sealant.** Aeromotive recommends Loctite 565 or equivalent PTFE based thread sealing paste.
9. Attach the fuel return line to the 3/8-NPT port located on the bottom of the regulator. Use the chart below to determine the minimum recommended return line size for your system. **Please note that these ports are pipe threads and will require the use of a pipe thread sealant.**

Regulator with 3-20 psi spring
Fuel Line ID Chart

Return Line Length (ft.)	Fuel Pump Free Flow Rating (GPH)			
	1 to 60 GPH	60 to 120 GPH	120 to 180 GPH	180 to 250 GPH
0-5 feet	3/8"	3/8"	1/2"	1/2"
5-10 feet	3/8"	1/2"	1/2"	5/8"
10-15 feet	3/8"	1/2"	5/8"	3/4"
15-20 feet	1/2"	1/2"	5/8"	3/4"

Regulator with 20-65 psi spring
Fuel Line ID Chart

Return Line Length (ft.)	Fuel Pump Free Flow Rating (GPH)			
	1 to 60 GPH	60 to 120 GPH	120 to 180 GPH	180 to 250 GPH
0-5 feet	3/8"	3/8"	3/8"	3/8"
5-10 feet	3/8"	3/8"	3/8"	3/8"
10-15 feet	3/8"	3/8"	3/8"	1/2"
15-20 feet	3/8"	3/8"	3/8"	1/2"

IMPORTANT: This is a bypass regulator and MUST have a return line installed and it must be routed from the bottom/return port on the regulator and routed back to the top of the fuel cell. Failure to install a return line at least as big, or bigger, than is recommended in the chart above will result in uncontrolled high pressure and potential flooding of carbureted engines!

10. The Vacuum / Boost reference port is provided for fuel pressure to vacuum/boost compensation at a 1:1 rate, this is primarily used in blow-thru turbo or supercharged applications or for EFI systems using a vacuum/boost reference. In most cases this port is left open to reference atmospheric pressure.
12. **Double check that all connections are tight, and back the pressure adjusting stud out to the lowest setting. Install a suitable fuel pressure gauge and ensure that any spilled fuel and any fuel soaked shop towels are cleaned up and removed from the vicinity of the vehicle!**
13. Reconnect the battery and turn the ignition to the ON position **WITHOUT** starting the car. After several seconds, check the fuel pressure. If there is no fuel pressure, turn the ignition key to the OFF position, wait one minute, return the ignition to the ON position, and recheck the fuel pressure. Repeat this ignition OFF and ON procedure until the fuel pressure gauge registers fuel pressure.

14. **With the fuel pressure gauge registering fuel system pressure, check for fuel leaks from and around the Aeromotive regulator and all fuel lines and connections near the regulator! If any fuel leaks are found, turn the ignition key to the OFF position, remove any spilled fuel and repair the leak before proceeding!**
15. Once the fuel pressure gauge registers fuel system pressure and there are no fuel leaks, start the engine and adjust the regulator to the desired fuel pressure. Turning the adjustment screw clockwise or in will increase fuel pressure, counter-clockwise or out will reduce fuel pressure.
16. Once the desired fuel pressure is achieved, tighten the regulator adjustment jam nut and attach the vacuum line.
NOTE: THE REGULATOR WILL NOT HOLD FUEL PRESSURE ONCE THE FUEL PUMP SHUTS OFF.
17. Test drive the car to insure proper operation and re-check the fuel system for leaks. **If any leaks are found, immediately shut off the engine and repair the leak(s)!**

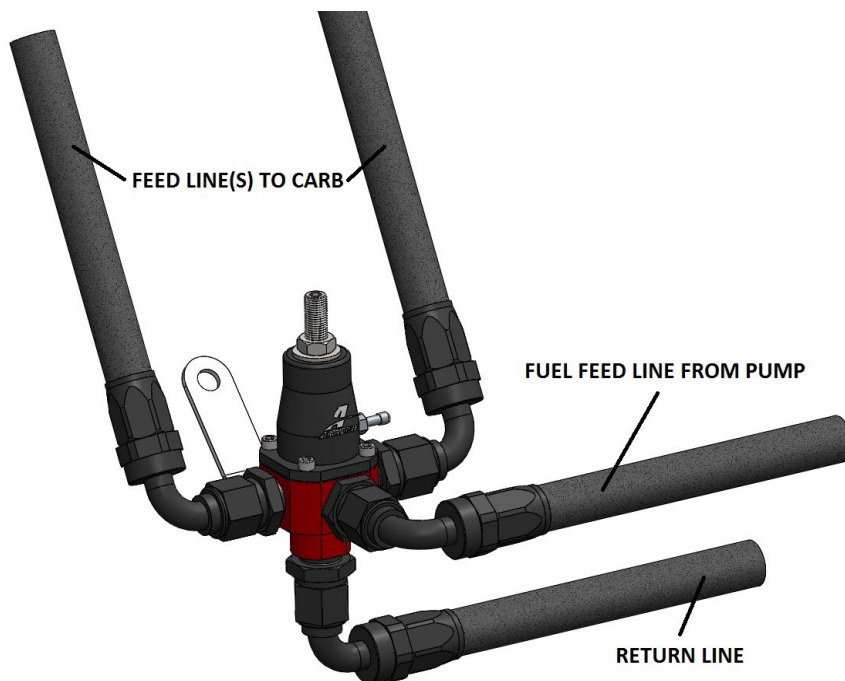

Typical Carburetor Plumbing

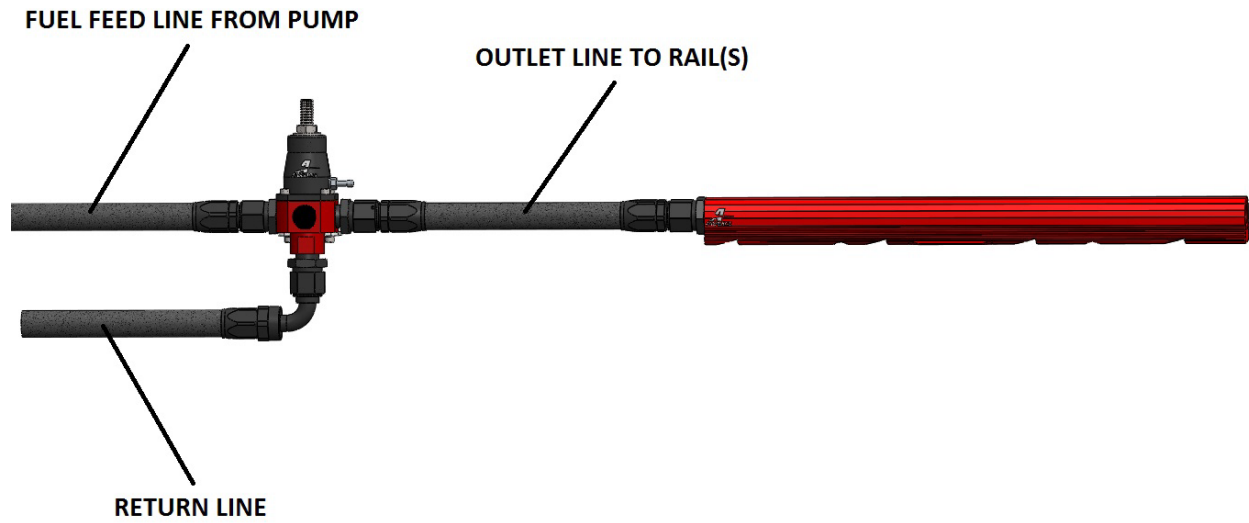

Single Fuel Rail (Returnless Rail) EFI Plumbing



Dual Fuel Rail (Ideal Flow-Through) EFI Plumbing

Contact US

RGA NUMBER REQUIRED FOR ALL RETURNS TO AEROMOTIVE.

To obtain an RGA number, please call (913) 647-7300 and ask for the Returns and Repairs department.

- **Shipping & Returns**
Aeromotive Inc.
10955 Mill Creek Road
Lenexa, KS 66219

General Inquiries and Tech Line: (913) 647-7300

General Email: info@aeromotiveinc.com

Tech Email: tech@aeromotiveinc.com

The Aeromotive Tech Lines are open Monday through Friday from 9:30AM to 5:00PM Central Standard Time.



WARNING: This product can expose you to chemicals, including chromium, which is known to the State of California to cause cancer or birth defects or other reproductive harm. For more information, visit: www.p65Warnings.ca.gov

AEROMOTIVE, INC. LIMITED WARRANTY

This Aeromotive Product, with proof of purchase dated on or after January 1, 2003, is warranted to be free from defects in materials and workmanship for a period of one year from the original date of purchase. No warranty claim will be valid without authentic, dated proof of purchase.

This warranty is to the original retail purchaser and none other and is available directly from Aeromotive and not through any point of distribution or purchase.

If a defect is suspected, the retail purchaser must contact Aeromotive directly to discuss the problem, possible solutions and obtain a Return Goods Authorization (RGA), if deemed necessary by the company. Please call 913-647-7300 and dial option 3 for the technical service dept. All returns must be shipped freight pre-paid to the company and with valid RGA before they will be processed.

Aeromotive will examine any product returned with the proper authorization to determine if the failure resulted from a defect or from abuse, improper installation, misapplication or alteration. Aeromotive will then, at it's sole discretion, return, repair or replace the product.

If any Aeromotive product is determined defective, buyer's exclusive remedy is limited in value to the sale price of the good. In no event shall Aeromotive be liable for incidental or consequential damages.

Aeromotive expressly retains the right to make changes and improvements in any product it manufactures and sells at any time. These changes and improvements may be made without notice at any time and without any obligation to change the catalogs or printed materials.

Aeromotive expressly retains the right to discontinue at any time and without notice any Aeromotive product that it manufactures or sells.

This warranty is limited and expressly limits any implied warranty to one year from the date of the original retail purchase on all Aeromotive products.

No person, party or corporate entity other than Aeromotive shall have the right to: determine whether or not this Limited Warranty is applicable to any Aeromotive product, authorize any action whatsoever under the terms and conditions of this Limited Warranty, assume any obligation or liability of any nature whatsoever on behalf of Aeromotive under the terms and conditions of this Limited Warranty.

This Limited Warranty covers only the product itself and not the cost of installation or removal.

This Limited Warranty is in lieu of and expressly excludes any and all other warranties, expressed or implied. This Limited Warranty gives you specific legal rights, and you may also have other rights which vary from state to state.