



13220 EFI-To-Carb Dual Regulator Installation Instructions

WARNING!

The fuel system is under pressure. Do not open the fuel system until the pressure has been relieved. Refer to the appropriate vehicle service manual for the procedure and precautions for relieving the fuel system pressure.

NOTE: The enclosed regulator will not necessarily seal to hold fuel pressure after the fuel pump stops running. In addition, testing the enclosed regulator by applying air pressure or vacuum to the vacuum/boost port with a hand-held pump will show a slight air leakage through the adjustment screw threads. This leakage is minute and is typical of all adjustable fuel pressure regulators. This does not, in any way, affect the performance of this regulator.

The Aeromotive regulator, Part #13220, utilizes three 3/8" NPT inlet/outlet ports, and one 3/8" NPT bypass or return port. The regulator also has three 1/8" NPT gauge ports. All NPT ports require the use of thread sealant equivalent to Loctite 565 for proper sealing.

CAUTION:

Installation of this product requires detailed knowledge of automotive systems and repair procedures. We recommend that this installation be carried out by a qualified automotive technician.

Installation of this product requires handling of gasoline. Ensure you are working in a well-ventilated area with an approved fire extinguisher nearby. Extinguish all open flames, prohibit smoking and eliminate all sources of ignition in the area of the vehicle before proceeding with the installation.

When installing this product, wear eye goggles and other safety apparel as needed to protect yourself from debris and sprayed gasoline.

Performance Specifications:

Pump Line Pressure Adjustment Range: 8-16 PSI
Carburetor Pressure Adjustment Range: 5-9 PSI

This regulator includes the following parts:

- 1 – 13220 EFI-To-Carb regulator
- 1 – 1/8" NPT 45-degree Street Elbow (gauge adapter)

Aeromotive system components are not legal for sale or use on emission controlled motor vehicles. The following steps are typical of most installations:

1. Once the engine has been allowed to cool, disconnect the negative battery cable and relieve the fuel system pressure.
2. Remove any cosmetic covers necessary to allow access to the EFI intake manifold.
3. Place shop towels around the factory supply and return line connections to catch any gasoline that is spilled and disconnect the supply and return lines.
4. Remove the factory EFI intake manifold and install the carbureted manifold and carburetor.
5. Find a suitable place in the engine compartment to mount the EFI-To-Carb regulator. Using the supplied mounting bracket as a template, mark the bracket mounting holes and drill for #10 screws.
6. Remove the bracket from the regulator and mount it to the vehicle using two #10 screws, nuts and lock washers (not provided). Once the bracket is mounted, reattach the regulator to the bracket.
7. Adapt the factory supply and return lines to AN-06 or 3/8" high pressure fuel hose and route the supply line to the EFI-To-Carb regulator inlet port and the return hose to the regulator return port.
8. Attach the supply line from the pump to the regulator inlet port (located at the side opposite the mounting bracket) using a 3/8" NPT to AN-06 or 3/8" NPT to 3/8" barb (port fittings not included).
9. Attach the fuel supply line(s) to the carburetor(s) using 3/8" NPT to AN-06 or barb fittings. If only one outlet port is used, install a 3/8" NPT port plug into the unused port (port fittings/plugs not included).

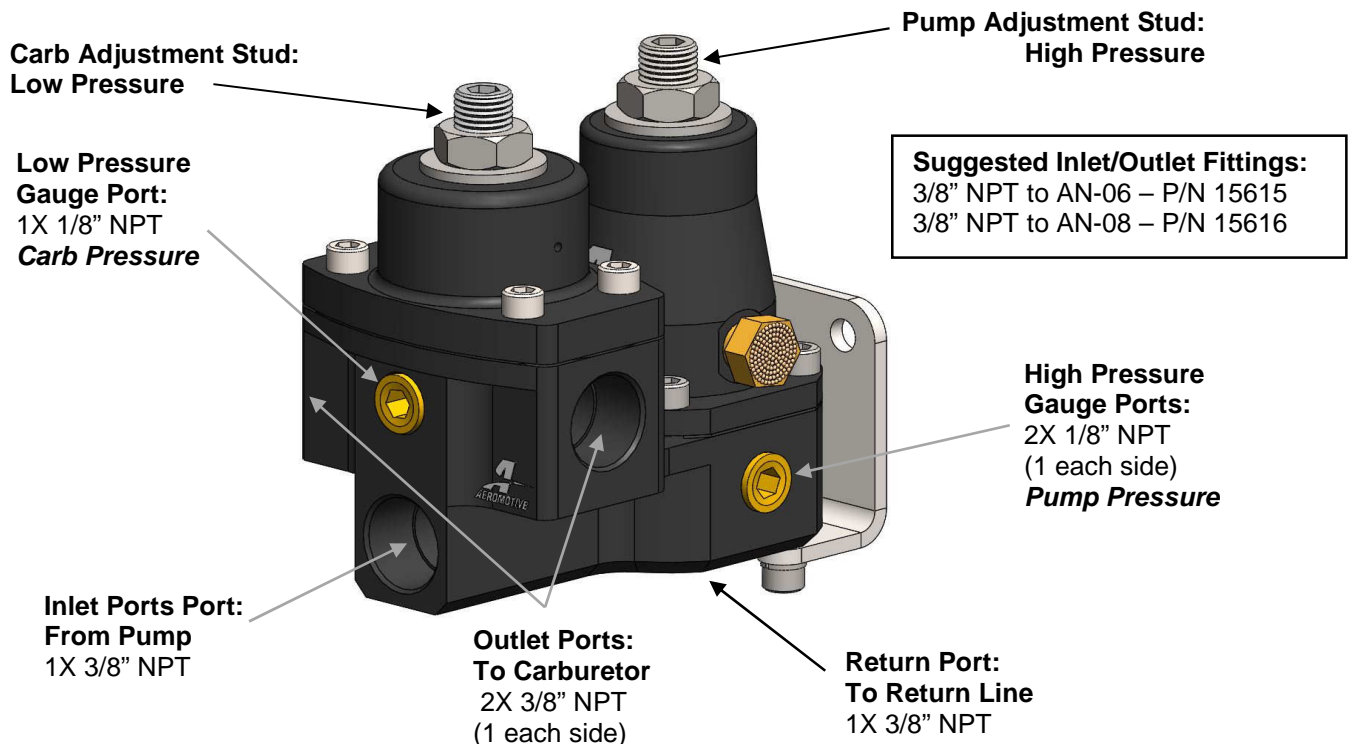

10. Attach the fuel return line to the regulator return port located on the **bottom** of the regulator, using a 3/8" NPT to AN-06 or barb fitting. Tighten all connections. **NOTE:** a return line **MUST** be used, routed from from the bottom (return) port, connected to the OEM return line, back to the top of the fuel tank.

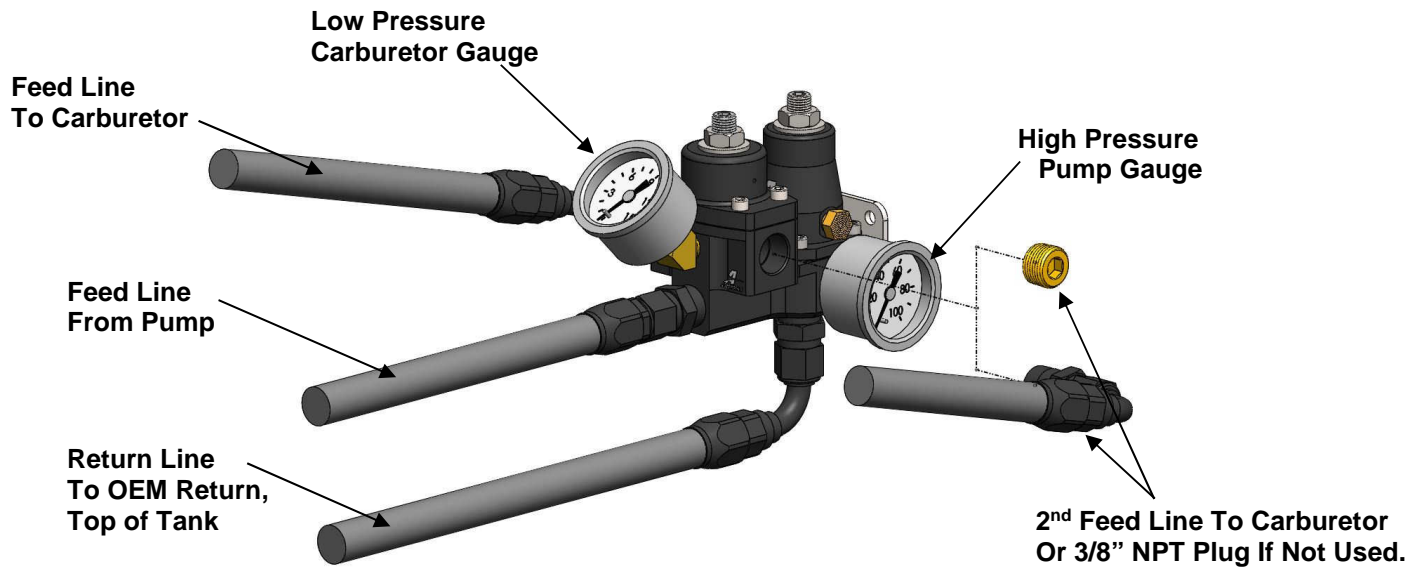

11. Install a suitable high pressure gauge in one of the 1/8" NPT high pressure gauge ports on either side of the pump regulator (Aeromotive P/N 15633, 0-100 psi gauge). Install the included 45-degree, 1/8" NPT street elbow into the 1/8" NPT low pressure gauge port in the front of the carb regulator and then the low pressure gauge into the street elbow. (Aeromotive P/N 15632, 0-15 psi gauge). Gauge connections require appropriate thread sealant such as Loctite 565 or equivalent.
12. **Ensure that any spilled gasoline and any gasoline soaked shop towels are cleaned up and removed from the vicinity of the vehicle!**
13. Loosen the jam-nut for the high and low pressure adjusting studs and back each stud out to the highest position (lowest pressure setting).
14. Reconnect the battery and turn the ignition to the ON position **WITHOUT** starting the car. After several seconds, check the pump fuel pressure (high pressure gauge). If there is no fuel pressure, turn the ignition key to the OFF position, wait one minute, return the ignition to the ON position, and recheck the fuel pressure. Repeat this ignition OFF and ON procedure until the high pressure gauge registers fuel pressure. You may then also see pressure register on the low pressure gauge
15. **With the fuel pressure gauges registering fuel system pressure, check for fuel leaks from and around the Aeromotive regulator. If any fuel leaks are found, turn the ignition key to the OFF position, remove any spilled fuel and repair the leak before proceeding!**
16. Once the fuel pressure gauges register fuel system pressure and there are no fuel leaks, start the engine and adjust the pump line (high pressure) regulator to approximately 12-14 psi. Turn the adjustment screw clockwise to increase pressure. Now adjust the carburetor supply (low pressure) regulator to the desired carburetor fuel pressure, again raising pressure with a clockwise rotation.
17. Once the desired fuel pressures are achieved, tighten the regulator adjustment jam nuts.
18. Test drive the car to insure proper operation and re-check the fuel system for leaks. **If any leaks are found, immediately shut off the engine and repair the leak(s)!**

AEROMOTIVE, INC.
 7805 Barton Street, Lenexa, KS 66214
 Phone: 913-647-7300 Fax: 913-647-7207



WARNING: This product can expose you to chemicals, including chromium, which is known to the State of California to cause cancer or birth defects or other reproductive harm. For more information, visit: www.p65Warnings.ca.gov

AEROMOTIVE, INC. LIMITED WARRANTY

This Aeromotive Product, with proof of purchase dated on or after January 1, 2003, is warranted to be free from defects in materials and workmanship for a period of one year from the original date of purchase. No warranty claim will be valid without authentic, dated proof of purchase.

This warranty is to the original retail purchaser and none other and is available directly from Aeromotive and not through any point of distribution or purchase.

If a defect is suspected, the retail purchaser must contact Aeromotive directly to discuss the problem, possible solutions and obtain a Return Goods Authorization (RGA), if deemed necessary by the company. Please call 913-647-7300 and dial option 3 for the technical service dept. All returns must be shipped freight pre-paid to the company and with valid RGA before they will be processed.

Aeromotive will examine any product returned with the proper authorization to determine if the failure resulted from a defect or from abuse, improper installation, misapplication or alteration. Aeromotive will then, at it's sole discretion, return, repair or replace the product.

If any Aeromotive product is determined defective, buyer's exclusive remedy is limited in value to the sale price of the good. In no event shall Aeromotive be liable for incidental or consequential damages.

Aeromotive expressly retains the right to make changes and improvements in any product it manufactures and sells at any time. These changes and improvements may be made without notice at any time and without any obligation to change the catalogs or printed materials.

Aeromotive expressly retains the right to discontinue at any time and without notice any Aeromotive product that it manufactures or sells.

This warranty is limited and expressly limits any implied warranty to one year from the date of the original retail purchase on all Aeromotive products.

No person, party or corporate entity other than Aeromotive shall have the right to: determine whether or not this Limited Warranty is applicable to any Aeromotive product, authorize any action whatsoever under the terms and conditions of this Limited Warranty, assume any obligation or liability of any nature whatsoever on behalf of Aeromotive under the terms and conditions of this Limited Warranty.

This Limited Warranty covers only the product itself and not the cost of installation or removal.

This Limited Warranty is in lieu of and expressly excludes any and all other warranties, expressed or implied. This Limited Warranty gives you specific legal rights, and you may also have other rights which vary from state to state.