



AEROMOTIVE
Part # 13101, 13109, 13114, 13128 & 13131
INSTALLATION INSTRUCTIONS

This product is not legal for sale or use on emission-controlled vehicles except when used as a direct replacement part matching OEM specification.

WARNING!



Always be aware of flammable situations. Drilling and grinding can be potential ignition sources. Extinguish all open flames, prohibit smoking and eliminate all sources of ignition in the area of the vehicle and workspace before proceeding with the installation. Ensure you are working in a well ventilated area with an approved fire extinguisher nearby.

WARNING!



etc.

Installation of this product requires modification to a fuel tank/ the fuel system, failure to satisfy all safety considerations will result in fire, explosion, injury and/or loss of life to yourself and/or others. All fuel system components **MUST** be located as far from heat sources as possible, like exhaust, engine block,

WARNING!



Mechanical and hydraulic lifting devices can tip over or lower accidentally due to incorrect maneuvering or technical errors. A falling object can cause injury and/or loss of life to yourself and/or others. When working under the vehicle, always use stands, and ensure that the ground or floor is stable and level. Never crawl under a vehicle which is only supported by a jack.

WARNING!



The fuel system is under pressure. Do not open the fuel system until the pressure has been relieved. Refer to the appropriate vehicle service manual for the procedure and precautions for relieving the fuel system pressure.

CAUTION!



When installing this product always wear safety glasses and other appropriate safety apparel. A drilling operation will cause flying metal chips. Flying metal chips can cause eye injury.

CAUTION:



Installation of this product requires detailed knowledge of automotive systems and repair procedures. We recommend that this installation be carried out by a qualified automotive technician. Careless installation of this product can result in damage to the product, injury or loss of life to yourself and/or others.

Compatible Fuels:

Pump Gas
Race Gas
E85
Alcohol/Ethanol

Part #13101, 13151 (Platinum Version) and 13114 (Marine Version) regulators utilize two o-ring sealed ORB-10 inlet/outlet ports and one o-ring sealed ORB-06 style bypass or return port.

P/N #13109 and 13159 (Platinum Version) are equipped with all ORB-06 ports for inlet/outlet and bypass/return connections.

ORB ports are **NOT PIPE THREAD** and utilize **NO THREAD SEALANT**. You must install ORB port fittings with o-rings, high pressure fuel lines and/or fuel injector rails to use this regulator. Each regulator has one 1/8" NPT gauge port which does require thread sealant to seal.

This regulator features a vacuum/boost port and fitting in the cap which, if connected to your intake manifold, will reference fuel pressure to manifold pressure. It works on a ratio of 1:1 with PSI, raising fuel pressure with boost and reducing it with vacuum. If unused, please do not plug.

Aeromotive system components are not legal for sale or use on emission controlled motor vehicles. The following steps are typical of most installations:

1. Once the engine has been allowed to cool, disconnect the negative battery cable and relieve the fuel system pressure.
2. Remove any cosmetic covers necessary to allow access to the fuel pressure regulator.
3. Remove the vacuum line from the regulator (some vehicles do not have vacuum operated regulators).
4. Place shop towels around the regulator to catch any gasoline that is spilled during this step of the installation. Remove any regulator mounting hardware and connecting fuel lines, then carefully remove the regulator.
5. Find a suitable place in the vehicle's engine compartment to mount the Aeromotive regulator. Using the supplied mounting bracket as a template, mark the bracket mounting holes and drill to accept a #10 screw.
6. With the bracket attached to the regulator, mount the bracket and regulator to the vehicle using two #10 screws, nuts and lock washers.
7. Attach the fuel line(s) from the fuel rail outlet port(s) to the regulator **side** ports using AN-10 (AN-06 if regulator is Aeromotive P/N 13109 or 13159) style fittings and o-rings. If only one inlet/outlet port is required (see figure 1-3 below) install an AN-10 style port plug with o-ring (AN-06 if regulator is Aeromotive P/N 13109 or 13159) into the unused port.

Suggested Inlet/Outlet Port Fittings:

P/N 13101, 13151, 13114
 ORB-10 to AN-10 – P/N 15608
 ORB-10 to AN-08 – P/N 15610
 ORB-10 to AN-06 – P/N 15609
 ORB-10 Port Plug – P/N 15610

P/N 13109, 13159
 ORB-06 to AN-06 – P/N 15606
 ORB-06 to AN-08 – P/N 15649
 ORB-06 Port Plug – P/N 15626

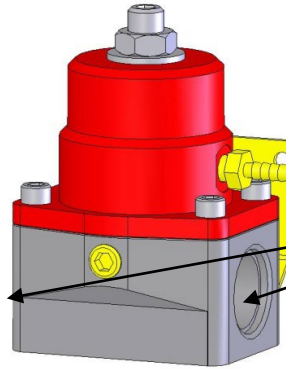

Inlet Ports/Outlet Ports Type/Size:
 ORB-10 – P/N 13101, 13151 & 13114
 ORB-06 – P/N 13109 & 13159

8. Attach the fuel return line to the regulator **bottom** port using an AN-6 style fitting and o-ring. Tighten all connections.

Suggested Bypass/Return Fittings:

P/N 13101, 13151, 13114
& P/N 13109, 13159
 ORB-06 to AN-06 – P/N 15606
 ORB-06 to AN-08 – P/N 15649

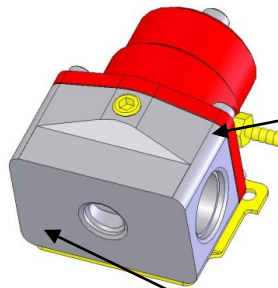

Vacuum/Boost Line
 Connection for 5/32" line

ORB-06
 Bypass/Return Port

9. Figure 1-1 depicts a fuel rail with only one fuel line connection, such as used in late model "returnless" fuel systems beginning in 1999. Positioning the regulator after the fuel rail is optimum for performance applications, however your new Aeromotive regulator may be configured for a "returnless" type of engine/fuel rail by flowing into one of the regulator side ports from the pump and out of the opposite side port into the fuel rail. A return line must be routed from from the regulator bottom/return port back to the top of the fuel tank.

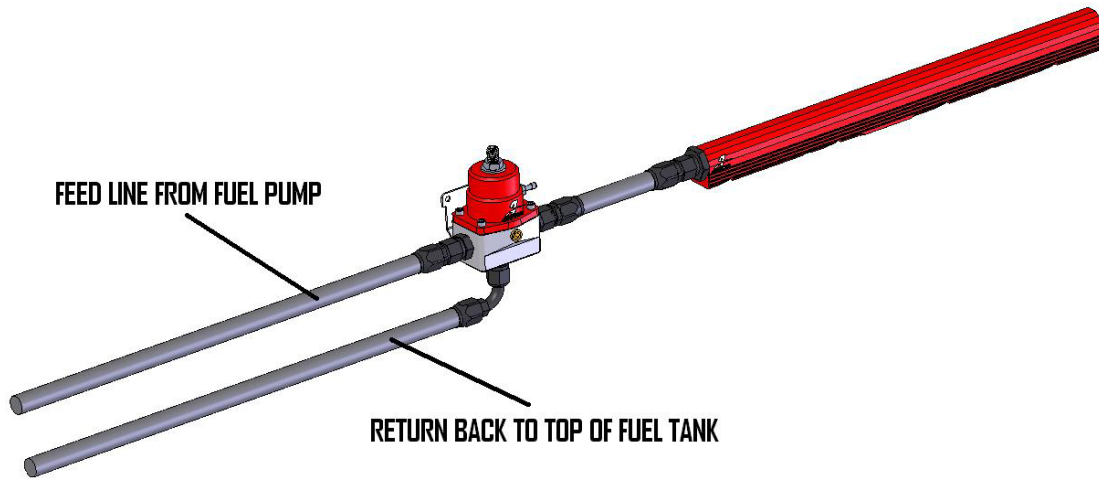

FIGURE 1-1

Figure 1-2 is optimum for performanc V8 engines with duel fuel rails, offering both inlet and outlet ports.

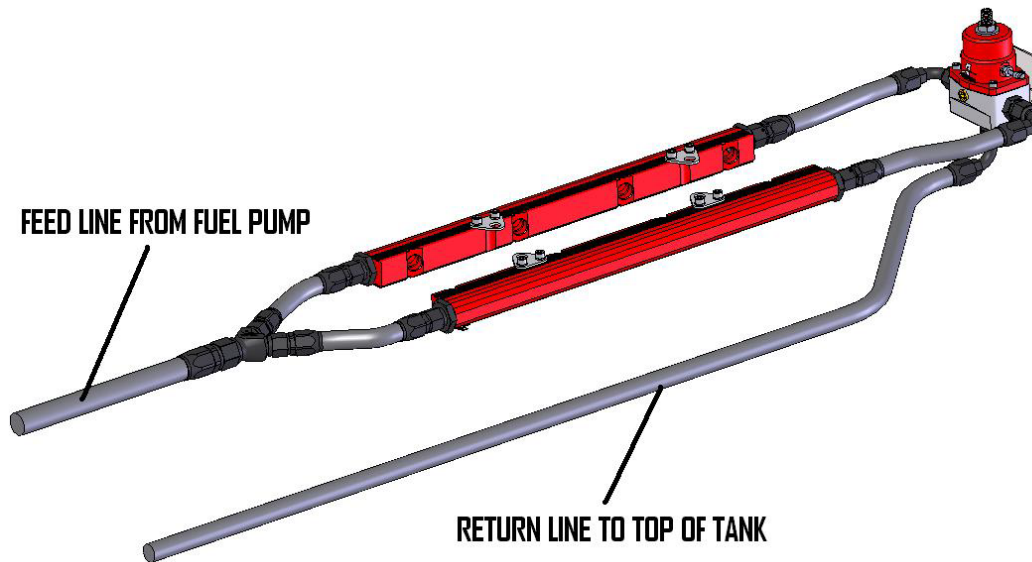

FIGURE 1-2

Figure 1-3 is optimum for single rail fuel rail applications equipped with both inlet and outlet ports.

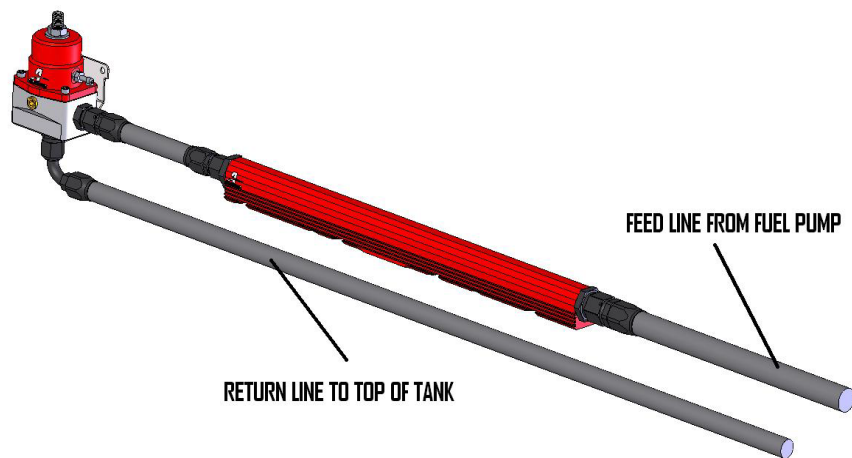

FIGURE 1-3

10. Once the regulator is installed, attach a suitable fuel pressure gauge to the 1/8 NPT port on the fuel pressure regulator (0-100psi 1.5" fuel pressure gauge, part # 15633). Requires thread sealant.
11. **Ensure that any spilled gasoline and any gasoline soaked shop towels are cleaned up and removed from the vicinity of the vehicle!**
12. Reconnect the battery and turn the ignition to the ON position **WITHOUT** starting the car. After several seconds, check the fuel pressure. If there is no fuel pressure, turn the ignition key to the OFF position, wait one minute, return the ignition to the ON position, and recheck the fuel pressure. Repeat this ignition OFF and ON procedure until the fuel pressure gauge registers fuel pressure.
13. **With the fuel pressure gauge registering fuel system pressure, check for fuel leaks from and around the Aeromotive regulator and all fuel lines and connections near the regulator! If any fuel leaks are found, turn the ignition key to the OFF position, remove any spilled fuel and repair the leak before proceeding!**
14. Once the fuel pressure gauge registers fuel system pressure and there are no fuel leaks, start the engine and adjust the regulator to the desired fuel pressure. Turning the adjustment screw clockwise will increase fuel pressure. OEM regulators are typically set at approximately 43 psi, without the vacuum line attached. The fuel pressure adjustment range for the enclosed regulator is 40-75 psi.

15. Once the desired fuel pressure is achieved, tighten the regulator adjustment jam nut and attach the vacuum line if the vehicle has one. If the vehicle is not equipped with a vacuum line, leave vacuum port open to atmosphere. Blocking the vacuum port will yield poor regulator performance. If vacuum port fitting becomes lost or broken replacement fittings can be purchased (part # 15630).
16. If you do not want to keep the fuel pressure gauge on the vehicle, relieve the fuel system pressure as instructed in the appropriate vehicle service manual and remove the fuel pressure gauge.
17. Test drive the car to insure proper operation and re-check the fuel system for leaks. **If any leaks are found, immediately shut off the engine and repair the leak(s)!**

Contact US

RGA NUMBER REQUIRED FOR ALL RETURNS TO AEROMOTIVE.

To obtain an RGA number, please call (913) 647-7300 and ask for the Returns and Repairs department.

- **Shipping & Returns**
Aeromotive Inc.
10955 Mill Creek Road
Lenexa, KS 66219

General Inquiries and Tech Line: (913) 647-7300

General Email: info@aeromotiveinc.com

Tech Email: tech@aeromotiveinc.com

The Aeromotive Tech Lines are open Monday through Friday from 9:30AM to 5:00PM Central Standard Time.



WARNING: This product can expose you to chemicals, including chromium, which is known to the State of California to cause cancer or birth defects or other reproductive harm. For more information, visit: www.p65Warnings.ca.gov

AEROMOTIVE, INC. LIMITED WARRANTY

This Aeromotive Product, with proof of purchase dated on or after January 1, 2003, is warranted to be free from defects in materials and workmanship for a period of one year from the original date of purchase. No warranty claim will be valid without authentic, dated proof of purchase.

This warranty is to the original retail purchaser and none other and is available directly from Aeromotive and not through any point of distribution or purchase.

If a defect is suspected, the retail purchaser must contact Aeromotive directly to discuss the problem, possible solutions and obtain a Return Goods Authorization (RGA), if deemed necessary by the company. Please call 913-647-7300 and dial option 3 for the technical service dept. All returns must be shipped freight pre-paid to the company and with valid RGA before they will be processed.

Aeromotive will examine any product returned with the proper authorization to determine if the failure resulted from a defect or from abuse, improper installation, misapplication or alteration. Aeromotive will then, at it's sole discretion, return, repair or replace the product.

If any Aeromotive product is determined defective, buyer's exclusive remedy is limited in value to the sale price of the good. In no event shall Aeromotive be liable for incidental or consequential damages.

Aeromotive expressly retains the right to make changes and improvements in any product it manufactures and sells at any time. These changes and improvements may be made without notice at any time and without any obligation to change the catalogs or printed materials.

Aeromotive expressly retains the right to discontinue at any time and without notice any Aeromotive product that it manufactures or sells.

This warranty is limited and expressly limits any implied warranty to one year from the date of the original retail purchase on all Aeromotive products.

No person, party or corporate entity other than Aeromotive shall have the right to: determine whether or not this Limited Warranty is applicable to any Aeromotive product, authorize any action whatsoever under the terms and conditions of this Limited Warranty, assume any obligation or liability of any nature whatsoever on behalf of Aeromotive under the terms and conditions of this Limited Warranty.

This Limited Warranty covers only the product itself and not the cost of installation or removal.

This Limited Warranty is in lieu of and expressly excludes any and all other warranties, expressed or implied. This Limited Warranty gives you specific legal rights, and you may also have other rights which vary from state to state.