



AEROMOTIVE
Part # 11217
Product Description
INSTALLATION INSTRUCTIONS

This product is not legal for sale or use on emission-controlled vehicles except when used as a direct replacement part matching OEM specification.

WARNING!



Always be aware of flammable situations. Drilling and grinding can be potential ignition sources. Extinguish all open flames, prohibit smoking and eliminate all sources of ignition in the area of the vehicle and workspace before proceeding with the installation. Ensure you are working in a well ventilated area with an approved fire extinguisher nearby.

WARNING!



etc.

Installation of this product requires modification to a fuel tank/ the fuel system, failure to satisfy all safety considerations will result in fire, explosion, injury and/or loss of life to yourself and/or others. All fuel system components **MUST** be located as far from heat sources as possible, like exhaust, engine block,

WARNING!



Mechanical and hydraulic lifting devices can tip over or lower accidentally due to incorrect maneuvering or technical errors. A falling object can cause injury and/or loss of life to yourself and/or others. When working under the vehicle, always use stands, and ensure that the ground or floor is stable and level. Never crawl under a vehicle which is only supported by a jack.

WARNING!



The fuel system is under pressure. Do not open the fuel system until the pressure has been relieved. Refer to the appropriate vehicle service manual for the procedure and precautions for relieving the fuel system pressure.

CAUTION!



When installing this product always wear safety glasses and other appropriate safety apparel. A drilling operation will cause flying metal chips. Flying metal chips can cause eye injury.

CAUTION:



Installation of this product requires detailed knowledge of automotive systems and repair procedures. We recommend that this installation be carried out by a qualified automotive technician. Careless installation of this product can result in damage to the product, injury or loss of life to yourself and/or others.

Compatible Fuels:

Pump Gas
Race Gas
E85
Alcohol/Ethanol

The enclosed Aeromotive regulator utilizes two o-ring sealed ORB-10 style ports, and one o-ring sealed ORB-08 style bypass port; These ports are **NOT PIPE THREAD** and utilize **NO THREAD SEALANT**. ORB port fittings with the proper o-ring installed are required.

The enclosed Aeromotive fuel pressure regulator is intended to be installed on the outlet side of an unmodified Aeromotive A3000 Fuel pump, Aeromotive p/n 11216 or 11222. It must be installed with a return line from the regulator to the top of the fuel tank. It is designed for the purpose of creating and maintaining stable line pressure in a range between 14-24 PSI, for carbureted engine applications where a dead-head or static style regulator is installed at the carburetor(s).

The regulator is **not** preset from the factory and **must be adjusted to 18 psi**.

This kit contains the following parts:

- 1ea 11217 By-Pass Style, HP (High Pressure) Regulator
- 2ea 1/4-28x 2-1/4" mounting screws
- 2ea Fuel pump mounting O-Rings (1 required, 1 spare)

Aeromotive system components are not legal for sale or use on emission controlled motor vehicles

Aeromotive Commonly used part numbers for your reference:

- 15608 ORB-10/AN-10 Port Fitting. (Outlet Fitting)
- 15607 ORB-08/AN-08 Port Fitting. (By-Pass Fitting)

The following steps are typical of most installations:

1. Once the engine has been allowed to cool, disconnect the negative battery cable and relieve fuel system pressure, referring to the appropriate vehicle service manual for the procedure on doing so.
2. Place clean shop towels around the fuel pump to catch any gasoline that may be spilled during its removal. Using caution, remove the fuel pump from the system.

Failure to satisfy all safety considerations will result in fire, explosion, injury and/or loss of life to yourself and/or others.

3. The included High Pressure (HP) Regulator with bypass (return line) must be located on the outlet side of the A3000 fuel pump. If using a “dead head” (non-return) style regulator at the carburetor (Aeromotive P/N 13208 or 13210 for example), the HP Regulator is typically mounted directly to the fuel pump outlet port. The HP Regulator assembly may be clocked relative to the pump in 45-deg increments for optimum clearance of the adjusting stud and bypass line. It may also be rotated 180 degrees (flipping inlet and outlet ports) to orient the bypass port on either side. Once the HP Regulator orientation is established, connect it to the pump using the provided o-ring and socket-head cap screws. **(FIGURE 1-1)**

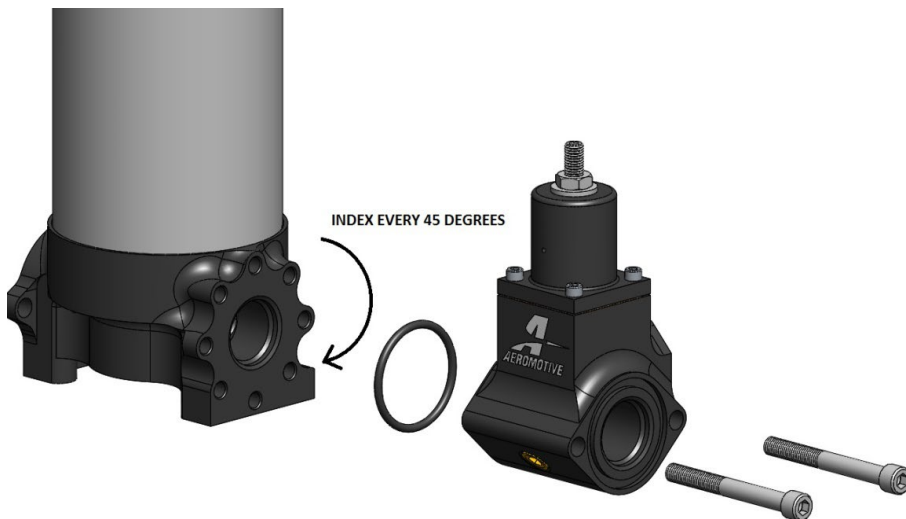
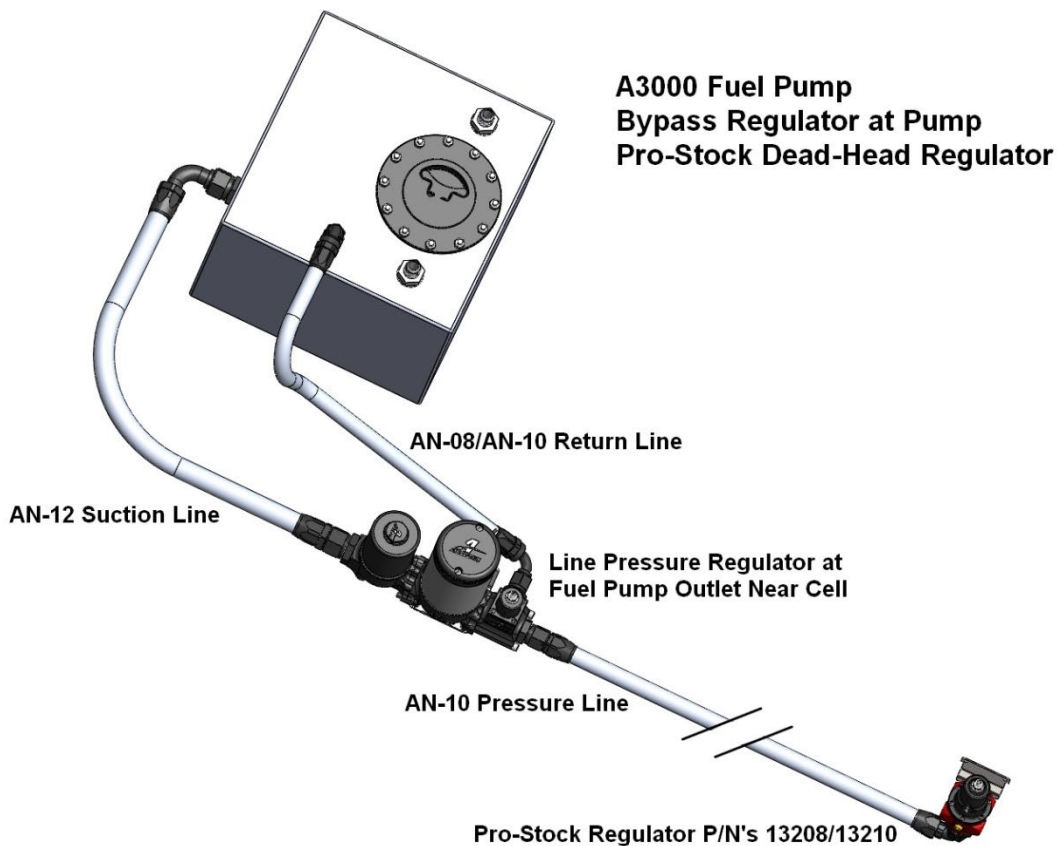

FIGURE 1-1

When installing o-rings it is important to place a small amount of light oil on both the o-ring and the mating surface to ease installation and prevent damaging the o-ring.

5. Thread the o-ring side of an ORB-08/AN-08 port fitting, such as P/N 15607, into the HP regulator bypass port and connect an AN-08 return line from the regulator up to the return fitting in the top of the fuel cell. The return flow must enter the tank in a manner that does NOT upset the fuel pump pickup or disturb the outgoing flow to the fuel pump. Avoid an in-tank drop-tube for the return that extends deeper than 1/3 down from the top of the fuel cell.
6. Thread the o-ring side of an ORB-10 to AN-10 port fitting, such as P/N 15608, into the HP regulator outlet port and connect an AN-10, high pressure fuel line with AN hose-ends to the regulator outlet port and up to the dead-head regulator mounted at the carburetor.
7. Attach a suitable 0-30 PSI fuel pressure gauge to the HP regulator test port if desired.
Note: The HP Regulator is adjustable from 14-24 PSI line pressure and has been pre-set for 18 PSI from the factory, ample to feed most dead-head style regulators.

Plumbing Diagram for Engines using Dead-Head Style regulator at the Carburetor such as Aeromotive Pro-Stock 4-Port P/N 13208 and 2-Port P/N 13210.



8. For engine applications with multiple carburetors, and/or multiple stages of nitrous, the need for separate, adjustable pressures means multiple dead-head regulators are often installed. In these applications, it may be advantageous to move the HP bypass regulator off the pump and into the engine compartment to better facilitate a full flow, dynamic fuel system. The A3000 HP Regulator is designed to “stack” onto the end of multiple, **Aeromotive stackable regulators (Aeromotive part # 13217)**. (**FIGURE 1-2**)



FIGURE 1-2

9. The “stackable” 13217 regulators are ideal for multiple carbs, with up to one regulator per float bowl, and/or per stage of nitrous systems. There is no limit to the number of 13217 Stackable Regulators that may be combined, with future expansion or contraction of the system taking only minutes to accomplish. The A3000 HP bypass regulator is frequently installed as the last regulator in-line with stackable regulators, creating a full flow, dynamic fuel system, at the desired line pressure for best fuel system performance. (**FIGURE 1-3**)

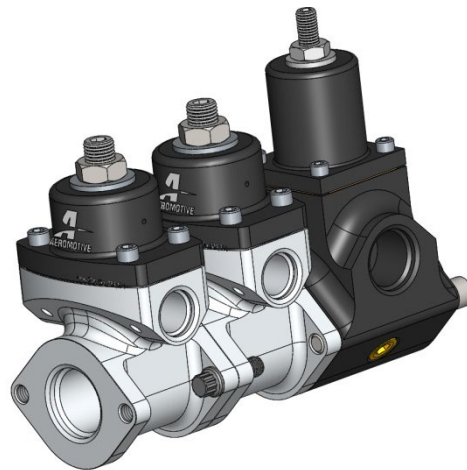
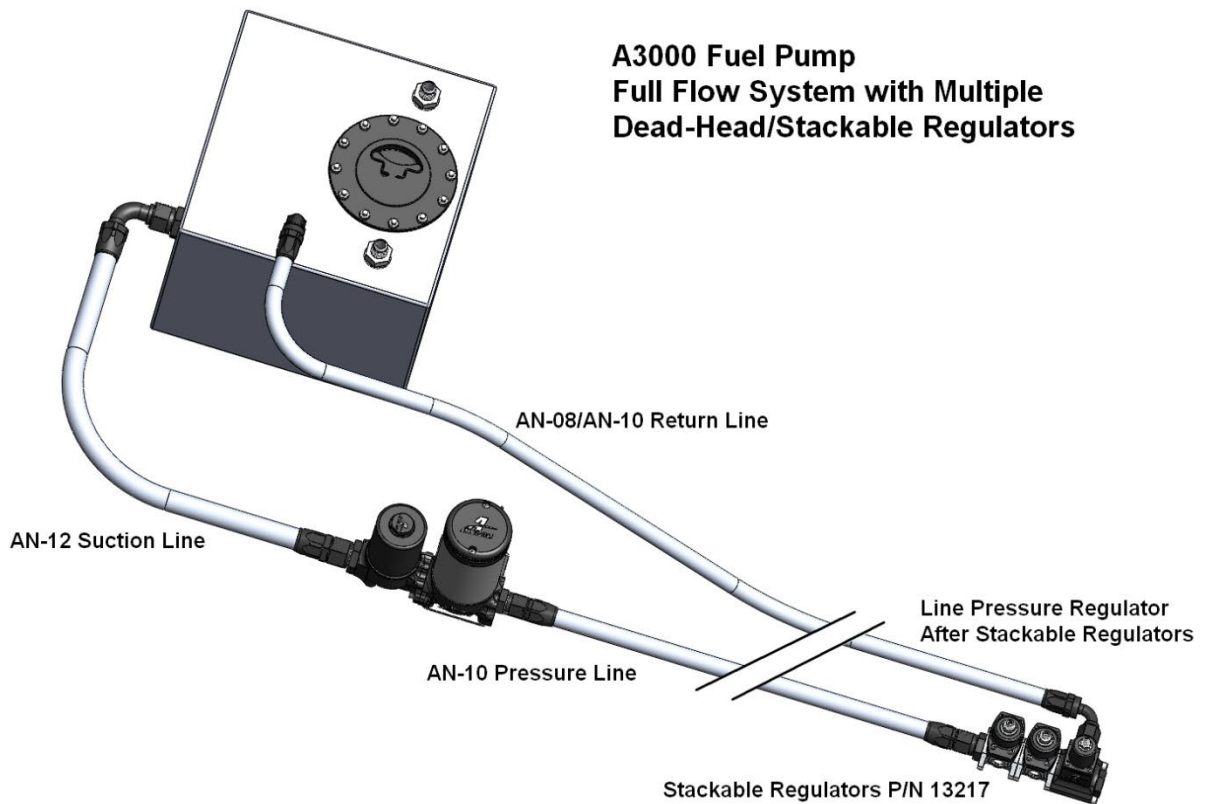

FIGURE 1-3

A3000 Pump with HP Bypass Regulator at the End of Stackable Regulators:



10. The HP Bypass Regulator may be coupled directly to the last Stackable Regulator using the included o-ring and fasteners. Thread the o-ring side of an ORB-08/AN-08 port fitting into the regulator return port and block the opposite (outlet) end with an ORB-10 port plug such as Aeromotive P/N 15617.
11. Plan the routing of and Install the AN-08 by-pass fuel line from the fuel HP Bypass Regulator return port back to the top of the fuel cell.

Note: Be sure to route all fuel lines clear of any moving suspension or drivetrain components, and any exhaust components! Protect fuel lines from abrasion and road obstructions or debris.

Ensure that any spilled gasoline and any gasoline soaked shop towels are cleaned up and removed from the vicinity of the vehicle!

12. Reconnect the battery and turn the ignition (fuel Pump) to the ON position **WITHOUT** starting the car. After several seconds, check the fuel pressure. If there is no fuel pressure, turn the ignition key to the OFF position, wait one minute, return the ignition to the ON position, and recheck the fuel pressure. Repeat this ignition OFF and ON procedure until the fuel pressure gauge registers fuel pressure.
- 10. With the fuel pressure gauge registering fuel system pressure, check for fuel leaks from and around all the fuel system components and all fuel lines and connections! If any fuel leaks are found, turn the ignition key to the OFF position, remove any spilled fuel and repair the leak before proceeding!**
11. Once the fuel pressure gauge registers fuel system pressure and there are no fuel leaks, start the engine and **adjust the fuel pressure regulator to 18 psi.**
12. Turn off the engine and allow it to cool.
13. Test drive the car to insure proper operation and re-check the fuel system for leaks. **If any leaks are found, immediately shutoff the engine and repair the leak(s)**

Contact US

RGA NUMBER REQUIRED FOR ALL RETURNS TO AEROMOTIVE.

To obtain an RGA number, please call (913) 647-7300 and ask for the Returns and Repairs department.

- **Shipping & Returns**
Aeromotive Inc.
10955 Mill Creek Road
Lenexa, KS 66219

General Inquiries and Tech Line: (913) 647-7300

General Email: info@aeromotiveinc.com

Tech Email: tech@aeromotiveinc.com

The Aeromotive Tech Lines are open Monday through Friday from 9:30AM to 5:00PM Central Standard Time.



WARNING: This product can expose you to chemicals, including chromium, which is known to the State of California to cause cancer or birth defects or other reproductive harm. For more information, visit: www.p65Warnings.ca.gov

AEROMOTIVE, INC. LIMITED WARRANTY

This Aeromotive Product, with proof of purchase dated on or after January 1, 2003, is warranted to be free from defects in materials and workmanship for a period of one year from the original date of purchase. No warranty claim will be valid without authentic, dated proof of purchase.

This warranty is to the original retail purchaser and none other and is available directly from Aeromotive and not through any point of distribution or purchase.

If a defect is suspected, the retail purchaser must contact Aeromotive directly to discuss the problem, possible solutions and obtain a Return Goods Authorization (RGA), if deemed necessary by the company. Please call 913-647-7300 and dial option 3 for the technical service dept. All returns must be shipped freight pre-paid to the company and with valid RGA before they will be processed.

Aeromotive will examine any product returned with the proper authorization to determine if the failure resulted from a defect or from abuse, improper installation, misapplication or alteration. Aeromotive will then, at it's sole discretion, return, repair or replace the product.

If any Aeromotive product is determined defective, buyer's exclusive remedy is limited in value to the sale price of the good. In no event shall Aeromotive be liable for incidental or consequential damages.

Aeromotive expressly retains the right to make changes and improvements in any product it manufactures and sells at any time. These changes and improvements may be made without notice at any time and without any obligation to change the catalogs or printed materials.

Aeromotive expressly retains the right to discontinue at any time and without notice any Aeromotive product that it manufactures or sells.

This warranty is limited and expressly limits any implied warranty to one year from the date of the original retail purchase on all Aeromotive products.

No person, party or corporate entity other than Aeromotive shall have the right to: determine whether or not this Limited Warranty is applicable to any Aeromotive product, authorize any action whatsoever under the terms and conditions of this Limited Warranty, assume any obligation or liability of any nature whatsoever on behalf of Aeromotive under the terms and conditions of this Limited Warranty.

This Limited Warranty covers only the product itself and not the cost of installation or removal.

This Limited Warranty is in lieu of and expressly excludes any and all other warranties, expressed or implied. This Limited Warranty gives you specific legal rights, and you may also have other rights which vary from state to state.