



AEROMOTIVE
Part # 11215
Product Description
INSTALLATION INSTRUCTIONS

This product is not legal for sale or use on emission-controlled vehicles except when used as a direct replacement part matching OEM specification.

WARNING!



Always be aware of flammable situations. Drilling and grinding can be potential ignition sources. Extinguish all open flames, prohibit smoking and eliminate all sources of ignition in the area of the vehicle and workspace before proceeding with the installation. Ensure you are working in a well ventilated area with an approved fire extinguisher nearby.

WARNING!



etc.

Installation of this product requires modification to a fuel tank/ the fuel system, failure to satisfy all safety considerations will result in fire, explosion, injury and/or loss of life to yourself and/or others. All fuel system components **MUST** be located as far from heat sources as possible, like exhaust, engine block,

WARNING!



Mechanical and hydraulic lifting devices can tip over or lower accidentally due to incorrect maneuvering or technical errors. A falling object can cause injury and/or loss of life to yourself and/or others. When working under the vehicle, always use stands, and ensure that the ground or floor is stable and level. Never crawl under a vehicle which is only supported by a jack.

WARNING!



The fuel system is under pressure. Do not open the fuel system until the pressure has been relieved. Refer to the appropriate vehicle service manual for the procedure and precautions for relieving the fuel system pressure.

CAUTION!



When installing this product always wear safety glasses and other appropriate safety apparel. A drilling operation will cause flying metal chips. Flying metal chips can cause eye injury.

CAUTION:



Installation of this product requires detailed knowledge of automotive systems and repair procedures. We recommend that this installation be carried out by a qualified automotive technician. Careless installation of this product can result in damage to the product, injury or loss of life to yourself and/or others.

Compatible Fuels:

Pump Gas
Race Gas
E85
Alcohol/Ethanol

The enclosed Aeromotive fuel pump utilizes an o-ring sealed ORB-12 inlet and ORB-10 outlet ports. The enclosed bypass regulator utilizes an o-ring sealed, ORB-08 style by-pass port. These ports are **NOT PIPE THREAD** and utilize **NO THREAD SEALANT**. ORB port fittings with the proper o-ring installed are required. The recommended Aeromotive fittings are noted in the instructions below.

This fuel pump is intended for **RACING or LIMITED Street** applications. To get the most out of your new Aeromotive pump, **PROPER INSTALLATION IS VITAL**. We strongly recommend the following:

The correct installation of this pump requires that you:

- Utilize **AN-12 high pressure fuel lines, AN-12 hose-ends, ORB-12 port fittings and o-rings for all connections from the fuel cell to the fuel pump.**
- Using a fuel cell or tank with a back/bottom sump, mount your pump as close to and level with, or lower than the back/bottom of the fuel cell.
- Install a 10 micron post filter (gas only), or 40-micron SS filter (alcohol).
- For stock fuel tanks, a reservoir style sump must be installed. Exercise extreme caution and follow all manufacturers' recommendations for installation. Aeromotive recommends using Baffled Sump part # 18650.
- Tank/Fuel cell must have at least a 1/2" or AN-08 tank vent.
- For limited street duty, where continuous run time may exceed 30 minutes, a Fuel Pump Speed Controller **MUST** be installed, Aeromotive p/n 16306.

Failure to follow the above recommendations may result in fuel leakage, including bursting of the fuel lines, poor vehicle performance and/or decreased fuel pump service life! Improper installation will void all warranties for this product!

Aeromotive system components are not legal for sale or use on emission controlled motor vehicles.

Pump Specifications:

Outlet pressure/flow	0 psi / 400 GPH
By-Pass Pressure	18 psi pre-set, adjustable 14-24 PSI
Current Draw	12.5- amps @ 12 psi
Max Operating Voltage	16V

Aeromotive Commonly Used Fittings

15607 ORB-08 to AN-08 Male Flare (bypass fitting AN-08)
15641 ORB-08 to AN-10 Male Flare (bypass fitting AN-10)
15608 ORB-10 to AN-10 Male Flare (outlet fitting AN-10)
15610 AN-10 ORB to AN-08 Flare (outlet fitting only AN-08)
15612 AN-12 ORB to AN-12 Flare (inlet fitting AN-12)

Aeromotive AN-10 Fuel Filter P/N's (for post pump filtration only)

12301 Red 10-micron Fuel Filter	12304 Red 100-micron Fuel Filter
12321 Black 10-micron Fuel Filter	12324 Black 100-Micron Fuel Filter
12351 Chrome 10-micron Fuel Filter	12354 Chrome 100-micron Fuel Filter
12335 Red 40-micron Fuel Filter	12331 Black 100-micron Fuel Filter w/ Shutoff Valve

Aeromotive AN-12 Fuel Filter P/N's (100-m for pre-pump, 10-m and 40-m for post pump only.)

12302 Nickel 100-micron Fuel Filter	12332 Black 100-micron Fuel Filter w/ Shutoff Valve
12309 Hard-Coat Black 100-Micron Fuel Filter	12342 Nickel 40-micron Fuel Filter
12310 Nickel 10-micron Fuel Filter	12352 Chrome 100-micron Fuel Filter
12311 Hard Coat Black 10-Micron Fuel Filter	12360 Chrome 10-micron Fuel Filter

The following steps are typical of most installations:

1. Once the engine has been allowed to cool, disconnect the negative battery cable and relieve the fuel system pressure.
2. Disconnect the existing pump fuel lines. Plug the open fuel line ends to prevent foreign matter from entering the fuel system. Remove pump mounting screws and remove the existing pump. If you are replacing a similar competitor's fuel pump, the Aeromotive fuel pump comes with additional mounting bracket holes underneath the Aeromotive mounting bracket which may be compatible (**FIGURE 1-1**).

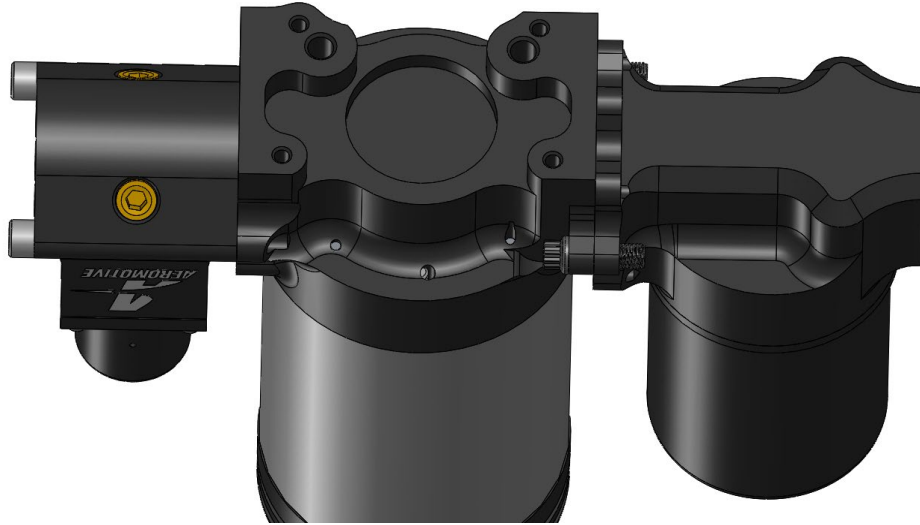

FIGURE 1-1

Note: ***DO NOT RUN THE PUMP DRY!!!*** Excessive wear occurs during dry run. ***DO NOT DISASSEMBLE THE PUMP!!!*** Tight tolerances and assembly calibration are an important key to pump performance. ***DISASSEMBLY WILL THROW THE PUMP OUT OF CALIBRATION AND VOID ANY/ALL WARRANTIES ON THIS PRODUCT.***

- Find a suitable place on the vehicle chassis to mount the Aeromotive fuel pump. Make sure the location will accommodate the pump mounting bolts, will position the pump at or below the sump, and is clear of the exhaust and any moving suspension or drivetrain components. Also, give careful consideration to keeping the pump clear of road obstructions or debris. The A3000 fuel pump is also equipped with an index-able pre-filter and bypass style regulator for line-pressure. This makes the final assembly more flexible, for fitment in any chassis. Note: **The supplied o-ring must be installed between the pump and regulator/filter to seal.** Both of these components may be indexed every 45 degrees (**FIGURE 1-2**).
- Using the pump mounting bracket as a template, mark and drill two mounting holes in the chassis to accept 1/4" bolts. Mount the fuel pump using two 1/4" bolts, nuts and lock washers. **Make sure and mount the pump in the vertical, upright position, motor pointing up.**

Note: Be sure to route all fuel lines clear of any moving suspension or drivetrain components, along with avoiding any hot exhaust components! Protect fuel lines from abrasion and road obstructions or debris.

- The 100-m prefilter must be installed on the inlet side of the A3000 fuel pump. With the pump in the area to be mounted, mock-up the pre-filter at the pump inlet port and determine the best clocking orientation. The filter assembly may be rotated relative to the pump in 45-deg increments for best clearance in the chassis. Once filter orientation is established, connect the filter to the pump using the provided o-ring and socket-head cap screws.
- Thread the o-ring side of an ORB-12/AN-12 port fitting such as P/N 15612 into the filter inlet.

FIGURE 1-2

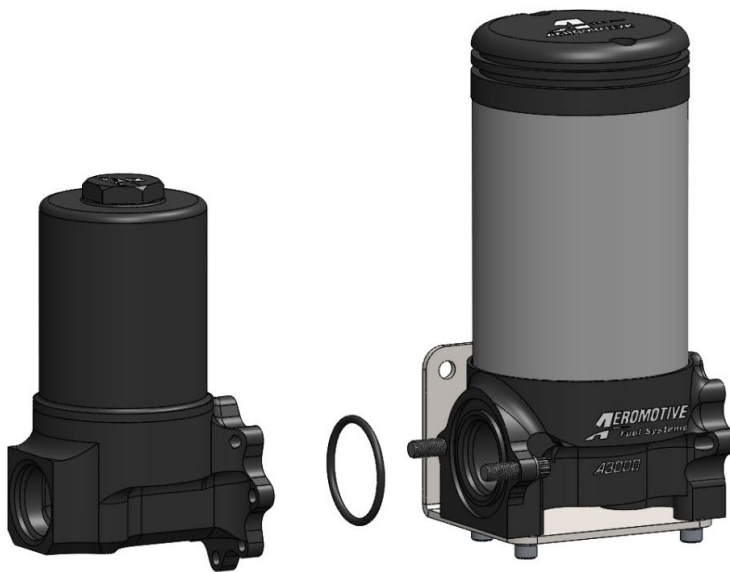

- Connect the AN-12 fuel cell outlet to the 100-micron pre-filter inlet using AN-12 fuel line and hose-ends. Use only "bent tube" or "flow-type" AN-12 hose-ends for angled connections. Keep the suction line as short as possible to minimize inlet flow restrictions and maximize pump performance and service life. If your fuel cell is not equipped with an AN-12 outlet, install an Aeromotive AN-12 fuel cell bulkhead such as Aeromotive P/N

15647.

8. The included High Pressure (HP) Regulator with bypass (return line) must be located on the outlet side of the A3000 fuel pump. If using a “dead head” (non-return) style regulator at the carburetor (Aeromotive P/N 13208 or 13210 for example), the HP Regulator is typically mounted directly to the fuel pump outlet port. With the pump in the area to be mounted, mock up the Regulator and determine the best clocking orientation. The HP Regulator assembly may be clocked relative to the pump in 45-deg increments for optimum clearance of the adjusting stud and bypass line. It may also be rotated 180 degrees (flipping inlet and outlet ports) to orient the bypass port on either side.
9. Once the HP Regulator orientation is established, connect it to the pump using the provided o-ring and socket-head cap screws. **(FIGURE 1-3)**

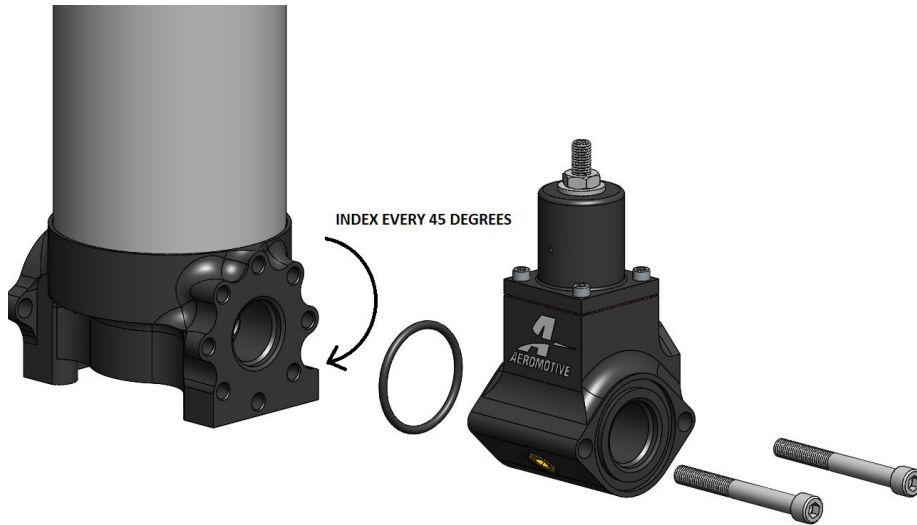

FIGURE 1-3

10. Thread the o-ring side of an ORB-08/AN-08 port fitting, such as P/N 15607, into the HP regulator bypass port and connect an AN-08 return line from the regulator up to the return fitting in the top of the fuel cell. The return flow must enter the tank in a manner that does NOT upset the fuel pump pickup or disturb the outgoing flow to the fuel pump. Avoid an in-tank drop-tube for the return that extends deeper than 1/3 down from the top of the fuel cell.
11. Attach a suitable 0-30 PSI fuel pressure gauge to the HP regulator test port if desired.
Note: The HP Regulator is adjustable from 14-24 PSI line pressure and has been pre-set for 18 PSI from the factory, ample to feed most dead-head style regulators.

IMPORTANT: for applications using a low pressure, carbureted bypass regulator, such as P/N 13202 or 13212, please remove the HP Bypass Regulator from the system.

12. Thread an ORB-10/AN-10 port fitting such as Aeromotive P/N 15608 into the Fuel Pump/HP Regulator outlet port. Using AN-10 high-pressure fuel line and hose-ends, connect the pump outlet to the post pump fuel filter. We recommend a 10-m post filter for gasoline engines P/N 12310 or 40-m SS element P/N 12342. P/N 12342 is also suitable for alcohol engines.
13. From the filter outlet port, Using ORB-10/AN-10 port fittings, high-pressure hose and hose-ends, connect the fuel filter outlet port to your Low Pressure, carburetor regulator, inlet port.

A3000 Pump with HP Bypass Regulator At The Fuel Pump Outlet Port:

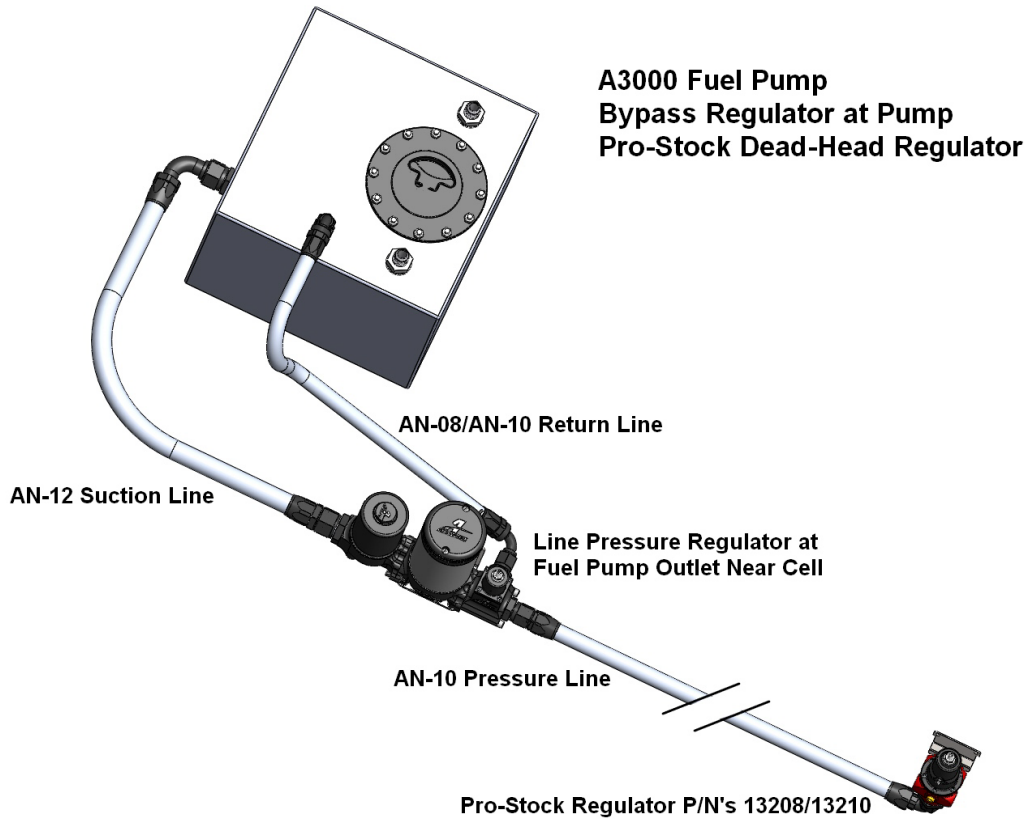

14. For engine applications with multiple carburetors, and/or multiple stages of nitrous, the need for separate, adjustable pressures means multiple dead-head regulators are often installed. In these applications, it may be advantageous to move the HP bypass regulator off the pump and into the engine compartment to better facilitate a full flow, dynamic fuel system. The A3000 HP Regulator is designed to “stack” onto the end of multiple, Aeromotive stackable regulators (Aeromotive part # 13217). **(FIGURE 1-4)**



FIGURE 1-4

15. The “stackable” 13217 regulators are ideal for multiple carbs, with up to one regulator per float bowl, and/or per stage of nitrous systems. There is no limit to the number of 13217 Stackable Regulators that may be combined, with future expansion or contraction of the system taking only minutes to accomplish. The A3000 HP bypass regulator is installed as the last regulator in-line, creating full flow through the stackable regulators and at the desired line pressure for best fuel system performance. (FIGURE 1-5)

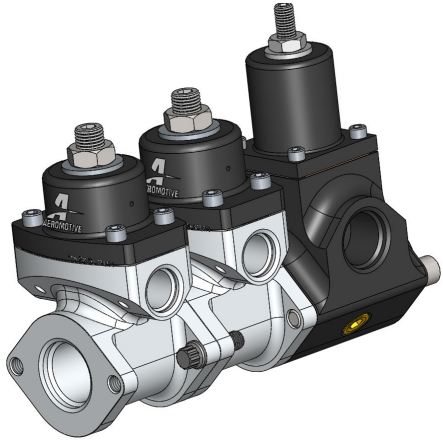
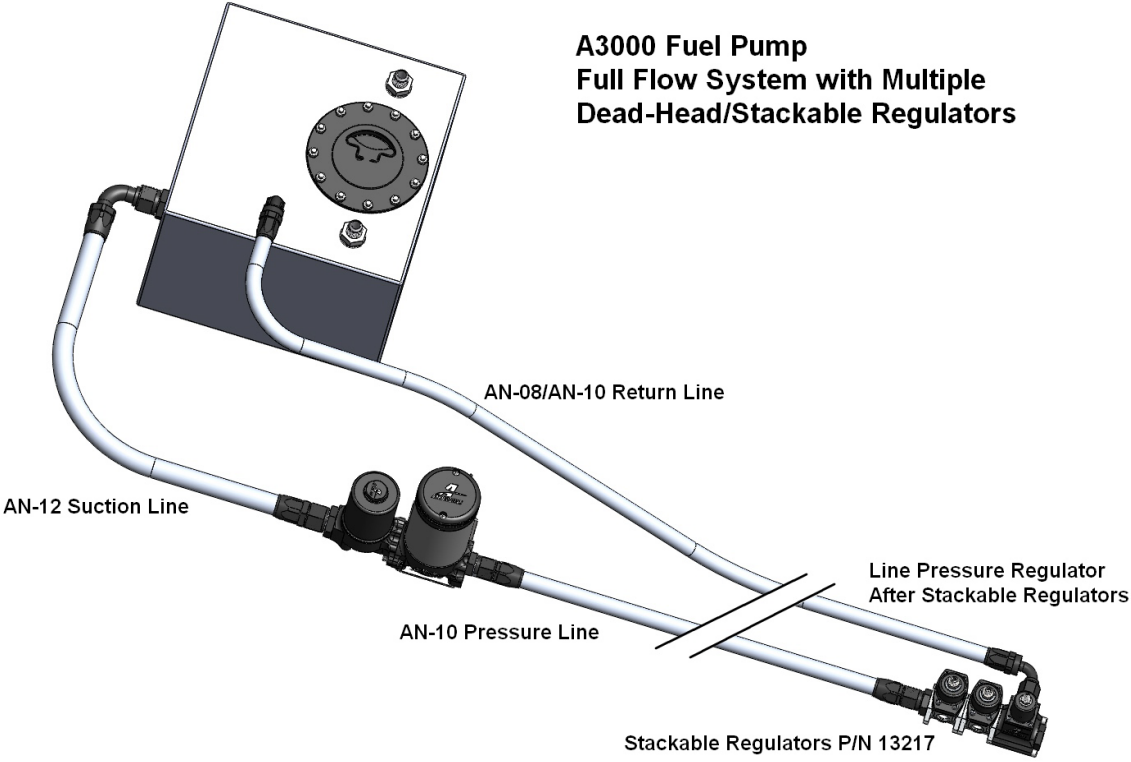

FIGURE 1-5

A3000 Pump With HP Bypass Regulator At The End of Stackable Regulators:



**A3000 Fuel Pump
Full Flow System with Multiple
Dead-Head/Stackable Regulators**

16. Insure that any spilled fuel and any fuel soaked shop towels are cleaned up and removed from the vicinity of the vehicle!

Note: Be sure to route all electrical wires clear of any moving suspension or drivetrain components and any exhaust components! Protect wires from abrasion and road obstructions or debris.

17. Connect electrical power (12 VDC) to the pump. Make sure you use stranded, insulated copper wire, in the sizes shown, with matching crimp-type connectors for all connections. Aeromotive has two types of wiring kits available, 16301 (assemble yourself) or a 16307 (pre-assembled). **CAUTION: The pump must not be connected directly to the battery.** Connect the Aeromotive fuel pump as shown in the following diagram:

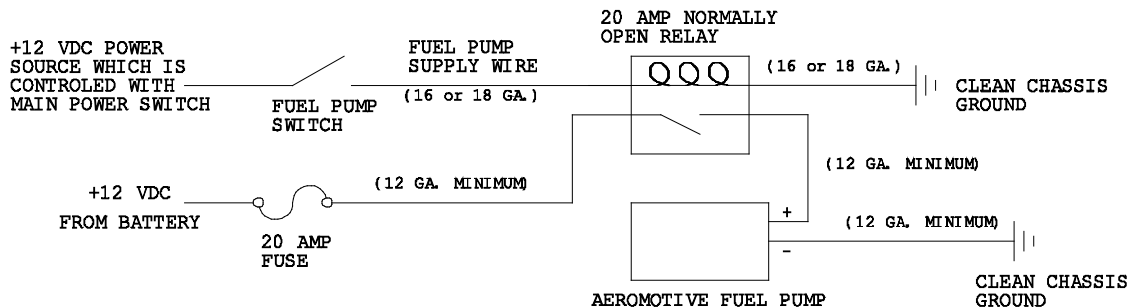

CAUTION: While performing the following steps, if any fuel leaks are detected, immediately turn the fuel pump OFF, remove any spilled fuel and repair the leak(s) before proceeding!

18. Turn the fuel pump ON **without starting the engine**, allow the pump to run for several seconds and check the fuel pressure. If there is no pressure, turn the fuel pump OFF, wait one minute, then turn the fuel pump ON and recheck the pressure. Repeat this fuel pump OFF and ON procedure until the gauge registers pressure or you detect a fuel leak. It may be necessary to loosen the fuel line fitting at the pressure regulator to bleed off excessive air in the system. Tighten any fuel line fittings which were loosened and insure that any spilled fuel is cleaned up and removed from the vicinity of the vehicle. If no pressure is registered on the gauge after running the pump for several seconds and you have found no leaks, check all fuel and electrical connections to determine the cause.
19. Once the fuel pressure gauge registers pressure, start the engine. The gauge on the fuel pressure regulator should register between 3 and 12 psi. If you have installed an adjustable fuel pressure regulator, adjust it to the desired setting.
20. The Pump Bypass regulator is pre-set at 18 PSI at the factory. If pump pressures above 18 psi are desired (as for limited duty such as drag racing applications) loosen the jam nut and turn the pump on. You can achieve this with the engine on or off by turning the adjustment screw clockwise to increase pressure, and counterclockwise to lower the pressure. When the desired pressure is obtained simply re-tighten the jam nut.
21. Shut the engine off. Using suitable clips and other mounting hardware, secure the newly installed fuel lines and electrical wires by attaching them to the vehicle chassis.

Test drive the vehicle to insure proper operation and re-check the fuel system for leaks. **If any leaks are found, immediately discontinue use of the vehicle and repair the leak(s)**

Contact US

RGA NUMBER REQUIRED FOR ALL RETURNS TO AEROMOTIVE.

To obtain an RGA number, please call (913) 647-7300 and ask for the Returns and Repairs department.

- **Shipping & Returns**
Aeromotive Inc.
10955 Mill Creek Road
Lenexa, KS 66219

General Inquiries and Tech Line: (913) 647-7300

General Email: info@aeromotiveinc.com

Tech Email: tech@aeromotiveinc.com

The Aeromotive Tech Lines are open Monday through Friday from 9:30AM to 5:00PM Central Standard Time.



WARNING: This product can expose you to chemicals, including chromium, which is known to the State of California to cause cancer or birth defects or other reproductive harm. For more information, visit: www.p65Warnings.ca.gov

AEROMOTIVE, INC. LIMITED WARRANTY

This Aeromotive Product, with proof of purchase dated on or after January 1, 2003, is warranted to be free from defects in materials and workmanship for a period of one year from the original date of purchase. No warranty claim will be valid without authentic, dated proof of purchase.

This warranty is to the original retail purchaser and none other and is available directly from Aeromotive and not through any point of distribution or purchase.

If a defect is suspected, the retail purchaser must contact Aeromotive directly to discuss the problem, possible solutions and obtain a Return Goods Authorization (RGA), if deemed necessary by the company. Please call 913-647-7300 and dial option 3 for the technical service dept. All returns must be shipped freight pre-paid to the company and with valid RGA before they will be processed.

Aeromotive will examine any product returned with the proper authorization to determine if the failure resulted from a defect or from abuse, improper installation, misapplication or alteration. Aeromotive will then, at it's sole discretion, return, repair or replace the product.

If any Aeromotive product is determined defective, buyer's exclusive remedy is limited in value to the sale price of the good. In no event shall Aeromotive be liable for incidental or consequential damages.

Aeromotive expressly retains the right to make changes and improvements in any product it manufactures and sells at any time. These changes and improvements may be made without notice at any time and without any obligation to change the catalogs or printed materials.

Aeromotive expressly retains the right to discontinue at any time and without notice any Aeromotive product that it manufactures or sells.

This warranty is limited and expressly limits any implied warranty to one year from the date of the original retail purchase on all Aeromotive products.

No person, party or corporate entity other than Aeromotive shall have the right to: determine whether or not this Limited Warranty is applicable to any Aeromotive product, authorize any action whatsoever under the terms and conditions of this Limited Warranty, assume any obligation or liability of any nature whatsoever on behalf of Aeromotive under the terms and conditions of this Limited Warranty.

This Limited Warranty covers only the product itself and not the cost of installation or removal.

This Limited Warranty is in lieu of and expressly excludes any and all other warranties, expressed or implied. This Limited Warranty gives you specific legal rights, and you may also have other rights which vary from state to state.