

Before installing this kit thread your O2 sensor BY HAND into and back out of the sensor fitting on the clamp band. Make sure there is very little resistance to threading into the fitting.

1. Locate a suitable place in the exhaust system to install the No-Weld O2 Sensor Mount. The mounting location must be on a straight section of the exhaust system free of bends for at least 2". On Non-Turbocharged Engines mount the O2 sensor in the exhaust system at least 18 inches downstream from the exhaust port. On turbocharged engines the O2 sensor must be installed after the turbocharger, ideally, at least 18" downstream from the turbocharger exhaust housing.

NOTE: If the sensor is mounted before the turbocharger the pressure differential will greatly affect the accuracy of the unit. For accurate readings, the sensor must be mounted before catalytic converters and/or auxiliary air pumps. To prevent collection of liquids between the sensor housing and sensor element during the cold start phase, the installation angle should be inclined at least 10° from horizontal with the electrical connection upwards, see diagram 1.

Drill a 13/16" – 7/8" hole where the O2 sensor is to be used.

2. Thoroughly clean the area around the exhaust pipe where the O2 sensor mount will be installed.

Step 1) Take the gasket strip with the hole in it, peel off the backing to expose the adhesive and position the gasket over the hole and apply pressure to stick the gasket to the exhaust tube. Note: The adhesive backed gasket is a ONE TIME use part so make sure positioning is correct.

Step 2) Take the second strip of gasket and DO NOT remove the backing! Line up the end of the blank gasket to the end of the gasket with the hole and wrap it around the pipe until it meets the opposite end of the gasket. Scribe a line where the two gaskets overlap.

Step 3) Cut off the excess gasket material so that the ends of the gasket do not overlap.

Step 4) Remove the backing from the blank gasket and apply it to the tube, see diagram 2.

3. Open the clamp band and position the O2 fitting over the hole and ensure the boss inserts into the hole. Assemble the end blocks, center block, bolts washers and nuts as shown in the diagram 3. Please note; on 2.25", 2.75" & 3.25" pipes the center block is not used. Tighten the nuts evenly until you achieve 10 lbs./ft. torque.

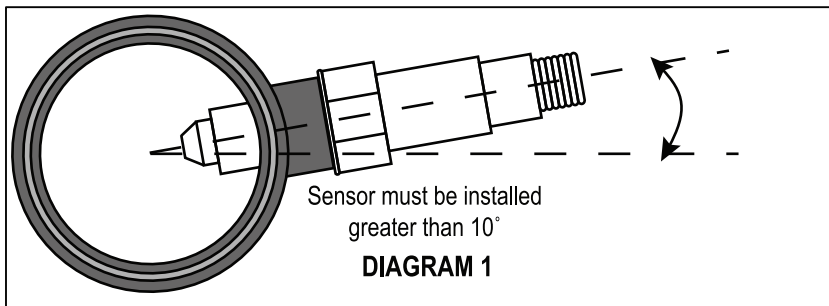

4. Install your O2 sensor into the fitting taking care not to damage the tip of the sensor. When tightening the O2 sensor into the No-Weld O2 Sensor Mount, be sure to hold the 1" (25mm) hex fitting in place with a second wrench so it does not slip or have any twisting forces placed on it.

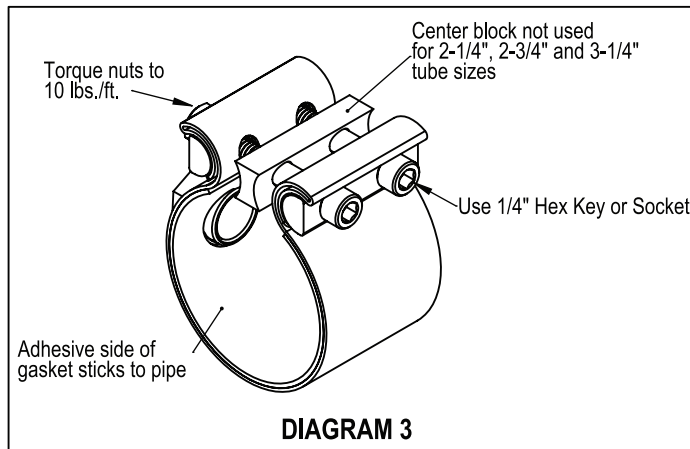
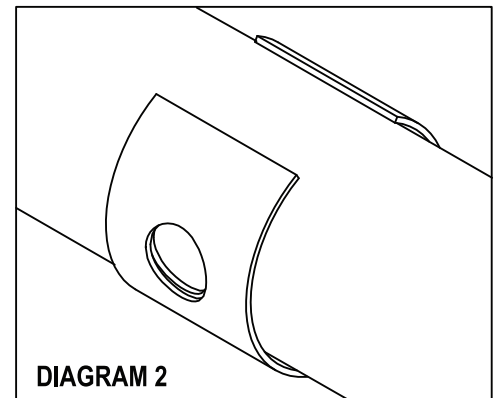

#### Warranty

Advanced Engine Management, Inc. warrants to the consumer that all AEM High Performance products will be free from defects in material and workmanship for a period of twelve (12) months from date of the original purchase. Products that fail within this 12 month warranty period will be repaired or replaced at AEM's option, when determined by AEM that the product failed due to defects in material or workmanship. This warranty is limited to the repair or replacement of the AEM part. In no event shall this warranty exceed the original purchase price of the AEM part nor shall AEM be responsible for special, incidental or consequential damages or cost incurred due to the failure of this product. **Warranty claims to AEM must be transportation prepaid and accompanied with dated proof of purchase.** This warranty applies only to the original purchaser of product and is non-transferable. All implied warranties shall be limited in

duration to the said 12 month warranty period. Improper use or installation, accident, abuse, unauthorized repairs or alterations voids this warranty. **An AEM Warranty Claim Form Must Accompany All Warranty Claims. Products returned to AEM with no Return Goods Authorization and or No Warranty Claim Form may be rejected and returned to sender.** AEM disclaims any liability for consequential damages due to breach of any written or implied warranty on all products manufactured by AEM. Warranty returns will only be accepted by AEM when accompanied by a valid Return Goods Authorization (RGA) number. Credit for defective products will be issued pending inspection. Product must be received by AEM within 30 days of the date RGA was issued. A copy of the AEM Warranty Claim Form can be e-mailed or faxed by contacting (310) 484-2322.

**For a PDF version of the instructions please visit us on the web at [www.aemelectronics.com](http://www.aemelectronics.com)**