

Instruction Manual



P/N 30-0313 X-SERIES GAUGE GPS SPEEDOMETER



STOP! - READ THIS BEFORE INSTALL OR USE!

WARNING:

THIS INSTALLATION MAY REQUIRE WELDING OR INTEGRATION INTO A VEHICLE'S ELECTRICAL SYSTEM. DAMAGE TO SENSITIVE ELECTRONICS, FIRE, OR EXPLOSION MAY OCCUR IF PROPER PRECAUTION IS NOT TAKEN. IF THERE IS ANY DOUBT, **DO NOT** ATTEMPT THE INSTALLATION AND CONSULT A PROFESSIONAL.

NOTE: IT IS THE RESPONSIBILITY OF THE ENGINE TUNER TO ULTIMATELY CONFIRM THE CALIBRATION USE FOR ANY PARTICULAR ENGINE IS SAFE FOR ITS INTENDED USE. AEM HOLDS NO RESPONSIBILITY FOR ANY ENGINE DAMAGE THAT RESULTS FROM THE MISUSE OF THIS PRODUCT.

Features

- 2-1/16" / 52mm outer diameter mounting
- 10Hz GPS receiver included
- Displays ground speed, course, and altitude
- AEMnet integration with AEM ECUs enables track mapping
- Simulated Vehicle Speed Sensor (VSS) output 12V pulse @ 4.444 Hz / MPH
- Peak recall
- US or Metric / SI display modes
- Black bezel / faceplate supplied; Silver/white available as optional purchase
- Locking connectors
- Auto-dimming
- Supports vehicle / system voltages up to 16V
- AEMnet (CAN bus) output

KIT CONTENTS	
PN	Description
10-0313	INST, X-SERIES GPS GAUGE
35-0313	GAUGE ASSY, X-SERIES GPS GAUGE
35-3457	GPS, RECEIVER 10HZ
35-4302	RED INSULATED BUTT CONNECTORS (6)
35-8618	NUT, KNURLED, M4x0.7 (2)
35-8614	BRACKET, X-SERIES GAUGE
35-8617	RUBBER BAND, X-SERIES GAUGE
35-3456	CABLE, X GAUGE PWR/IO GPS
35-3431	CABLE, X GAUGE SNSR - GPS

OPTIONAL ACCESSORIES	
PN	Description
30-0313-ACC	BEZEL, X-SERIES GAUGE SILVER FACEPLATE, X-SERIES 160 MPH, WHITE

Wiring Installation Diagram

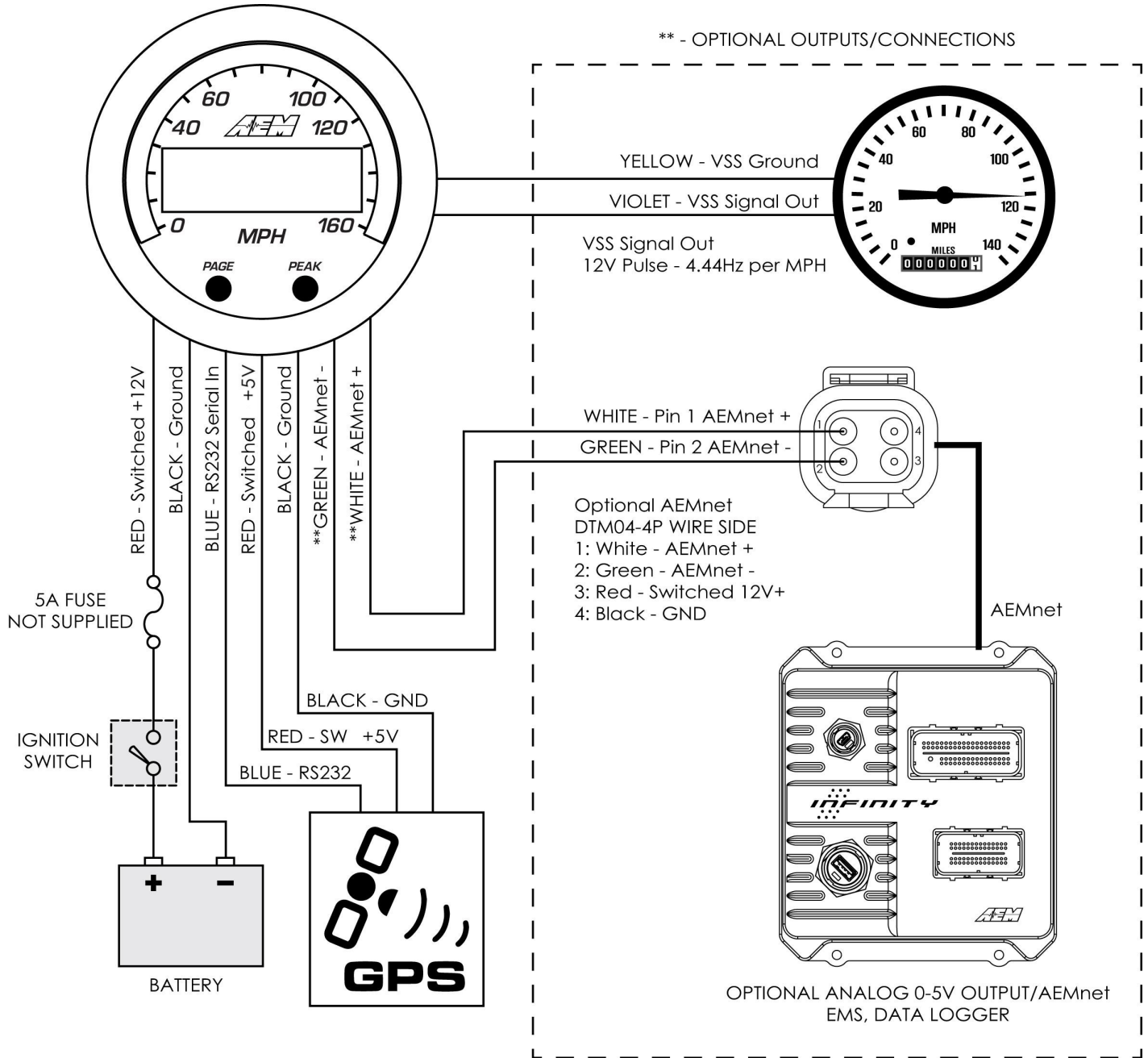

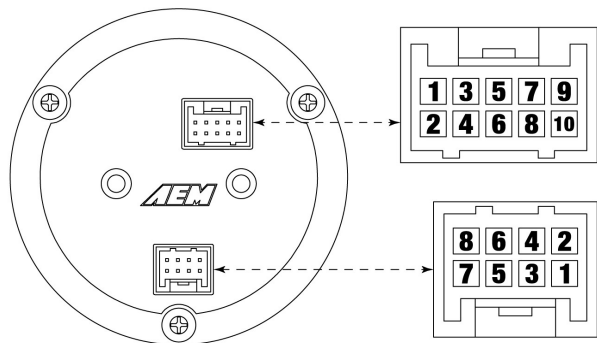

Connector A - Power / IO

Pin	Color	Description
1	RED	Switched 12V Power (5A Fuse)
2	BLACK	Power Ground
3	GREEN	AEMnet- / CANL
4	WHITE	AEMnet+ / CANH
5	BLUE	GPS Serial Input (RS-232)
6	PINK	GPS 5V Power
7	NC	NC
8	BLACK	GPS Serial Ground
9 - 10	NC	NC

Connector B - Aux

Pin	Color	Description
1	NC	NC
2	YELLOW	VSS Ground
3 - 7	NC	NC
8	VIOLET	VSS Output

Operation

The PAGE button may be depressed to scroll through the available GPS channels; an abbreviation of each channel name will be briefly displayed after each button press. The inner numeric LEDs and outer ring LED display the currently selected channel reading.

PAGE and PEAK buttons are located on the face of the gauge and are used to perform various functions, described below.

Display or clear stored peak value

- Press the PEAK button; the peak (highest) reading of the currently selected channel will be displayed and the outer LED will flash.
- The peak value will be retained across power cycles.
- While the peak value is being displayed, depress and hold the PEAK button for three seconds until "CLR" appears to clear the peak values.
- This operation will clear the peak values of ALL channels.



Will be displayed to confirm the peak value has been reset

- The gauge will return to normal display mode a few seconds after the last button press

Change channel display units US / SI (metric)

Notes

- The gauge should be in its normal display mode, showing the current parameter reading.
- Depress and hold the PAGE button for three seconds until US or SI appears.
- Press the PAGE button to toggle between US or SI (metric) modes.
- The gauge will return to normal display mode a few seconds after the last button press.
- "GPS" will be displayed when the GPS receiver is not connected or the gauge is not receiving any data from the GPS receiver. A green LED will be illuminated on the side of the GPS receiver when it is receiving power from the gauge and operational.
- "SAT" will be displayed when the gauge is receiving data from the GPS receiver but there are fewer than three satellites acquired. It may take up to 35 seconds for a "cold" start.

GPS Channels

Display Label	Description	US	SI	Notes
ALt	Altitude	ft	m	
HEAd	Heading (Course)	deg	deg	
Spd	Speed	mph	kph	

Pulse Output

A 12V 50% duty cycle variable frequency "pulse" output is provided on the 8-pin connector. This signal may be input into an external device such as a data logger, engine management system (ECU), or display device. The signal has a fixed scaling of 4.444 Hz per MPH.

For example, if you were travelling 55 MPH, the signal would output at 244 Hz / 50% duty cycle.

Here are some example conversion formulas:

- Hertz = MPH * 4.444
- Hertz = KPH * 1.609344 * 4.444
- MPH = Hertz / 4.444
- KPH = Hertz / (4.444 * 1.609344)

GPS Receivers

The AEM GPS Speedometer gauge is provided with an external 10Hz GPS receiver. The receiver is powered (5V) directly from the gauge itself and communicates at 38,400 bps. This receiver is water-resistant but not completely weather-proof; therefore, it should be mounted inside the vehicle with a clear view of the open sky. For example, beneath the windshield or on the rear package shelf would be acceptable locations. A green LED is located on the side of the receiver and visible through the translucent enclosure when the unit is powered and operational, i.e. connected to a powered gauge.

Faceplate / Bezel Installation

The gauge kit is supplied assembled with a black faceplate and black bezel. An accessory kit is available (for purchase through AEM dealers) which includes an optional silver bezel and white faceplate. Please reference the Optional Accessories section earlier in the document for the appropriate part numbers. Contact your dealer or visit www.aemelectronics.com for more information.

The faceplate may be reversible, displaying alternative scalings on either side. Reference the Operation section of this manual for details on how to switch the display mode when reversing the faceplate. Disassembly is required to change the faceplate, flip/reverse the faceplate, or change the bezel of the gauge. The following diagram will provide familiarization with the major components of the gauge prior to beginning the procedure.

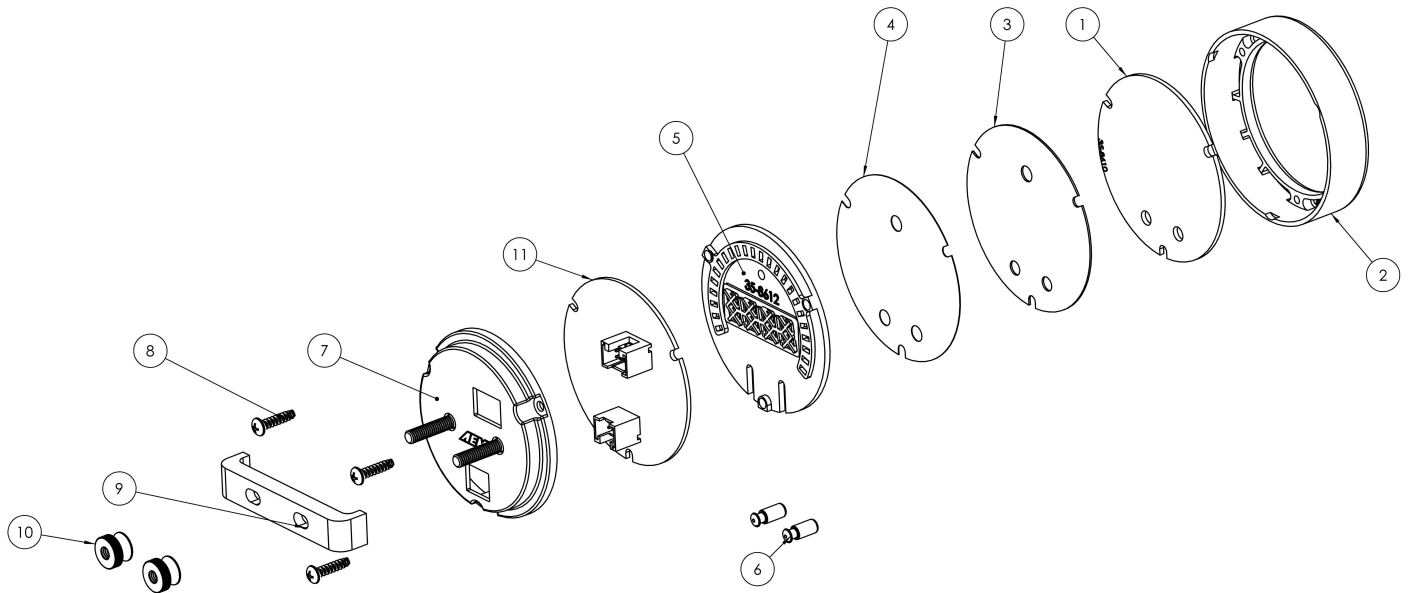

Item	Qty	Description
1	1	Lens
2	1	Bezel
3	1	Faceplate
4	1	Diffuser
5	1	Light Guide
6	2	Button
7	2	Mounting Stud (M4 x 0.7)
8	3	Assembly Screw
9	1	Mounting Bracket
10	2	Brass Thumb Screw (M4 x 0.7)
11	1	Printed Circuit Board (PCB)

Gauge Disassembly

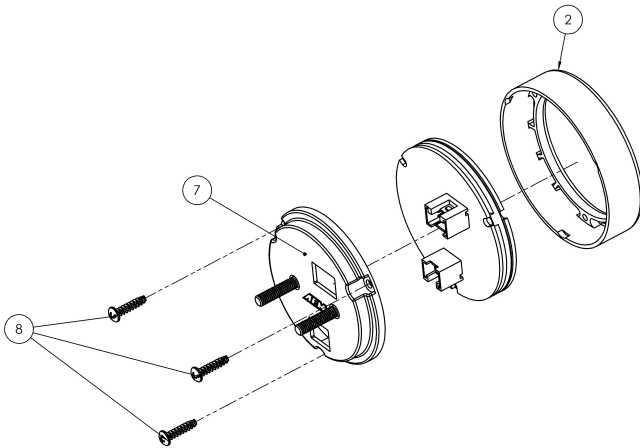

STEP 1 - Remove the three assembly screws (8) using a #1 Phillips head screwdriver. Separate the bezel (2) and cup (7) from the rest of the assembly. If you have purchased the optional accessory kit, the silver bezel may be replaced for the existing bezel at this time

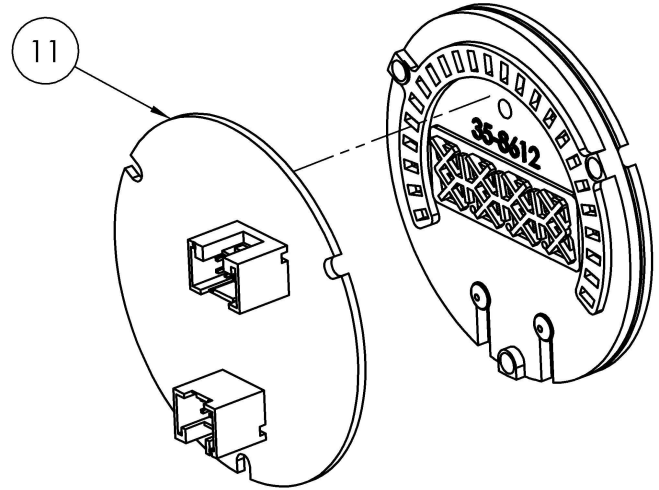

STEP 2 - Separate the PCB (11) from the remaining components

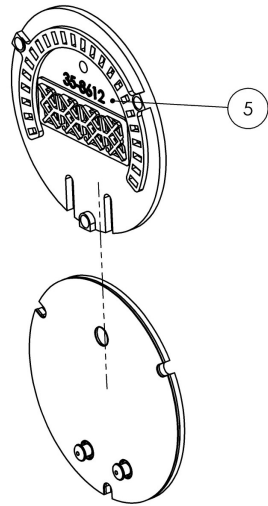

STEP 3 - Slide the light guide (5) upward to remove it, the buttons may fall out at this time - take care not to lose them

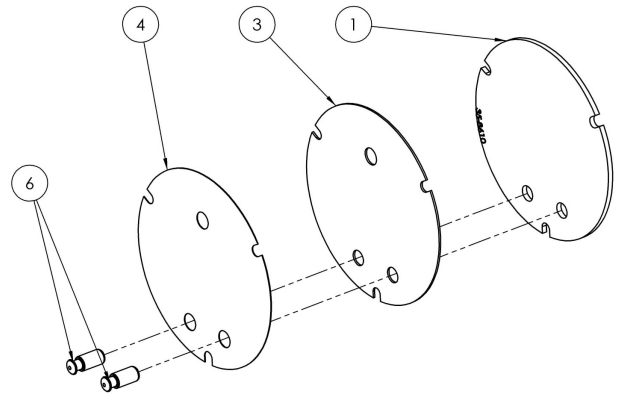

STEP 4 - As you separate the remaining components, diffuser (4), faceplate (3), lens (1), note the order in which they were assembled. The faceplate (3) may now be reversed to display an alternate scaling or replaced for a different color as included in the optional accessory kit

Gauge Assembly

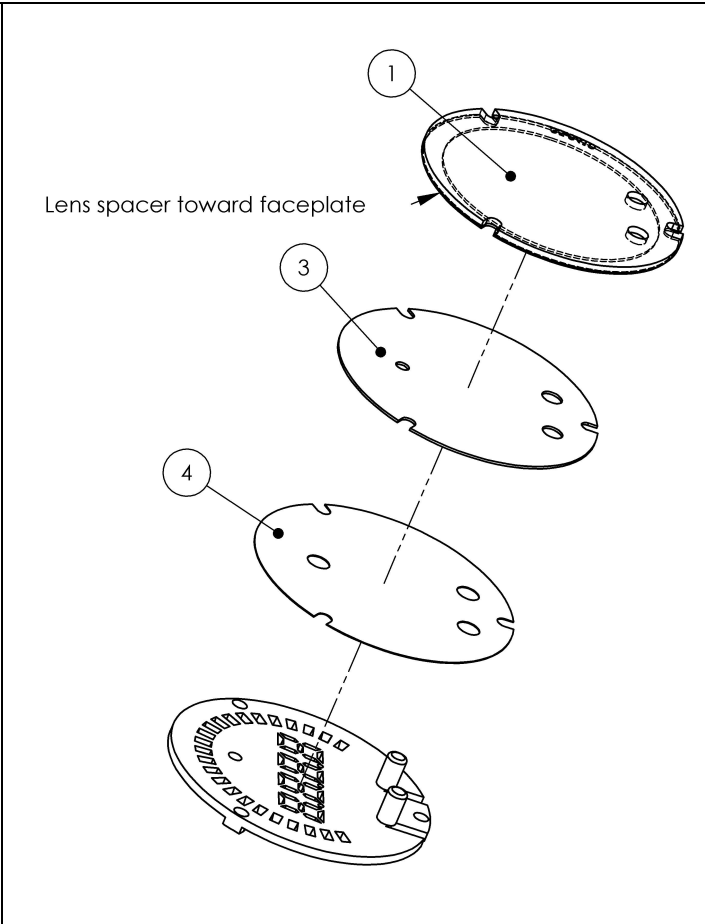
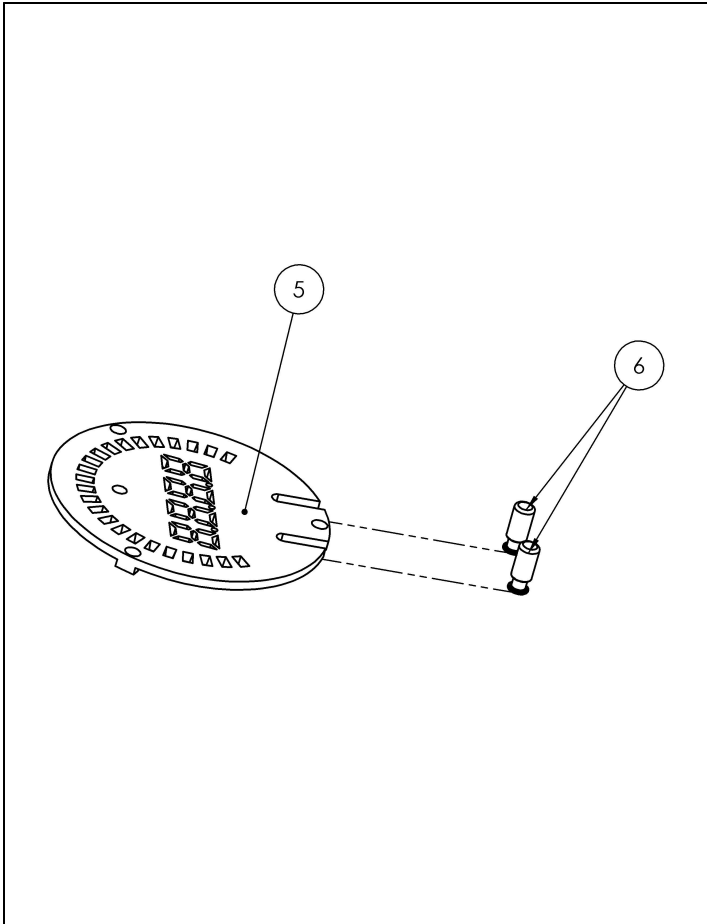

STEP 1 - Place the light guide (5) on a flat surface (black side up) and slide the buttons (6) into the slots

STEP 2 - Stack the diffuser (4), faceplate (3), and lens (1) in order, over the buttons, and on to the light guide

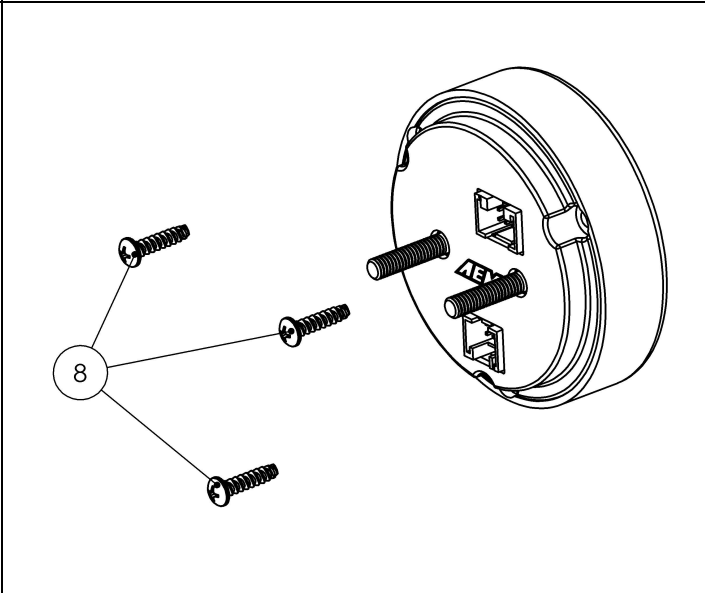
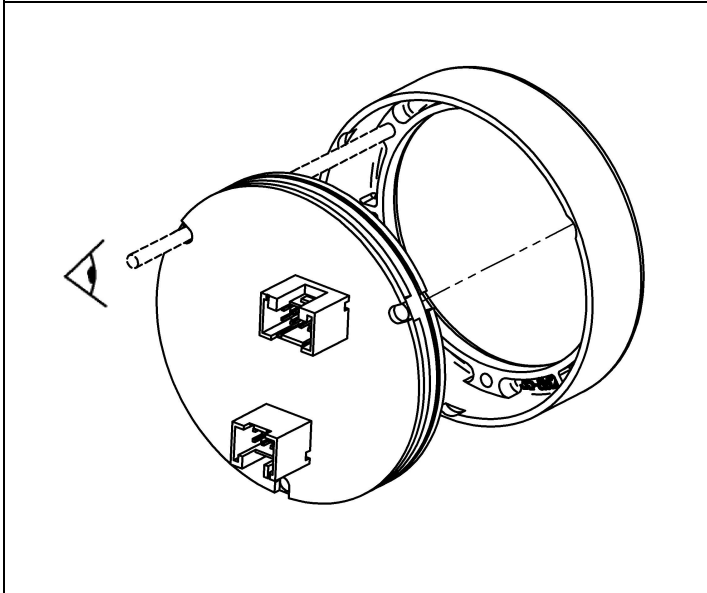

STEP 3 - Reassemble the PCB and display stack with the bezel, making sure screw holes are aligned through the entire assembly

STEP 4 - Reassemble and tighten screws to 2 in-lb (previously assembled bezel) or 3 in-lb (new bezel). **Do not over-tighten!**

Gauge Installation

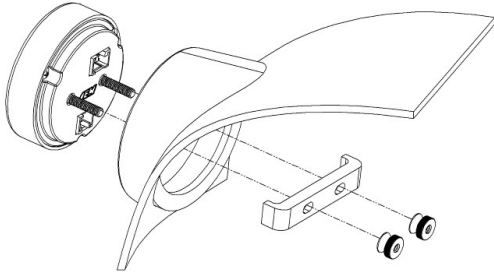

Installation using supplied bracket

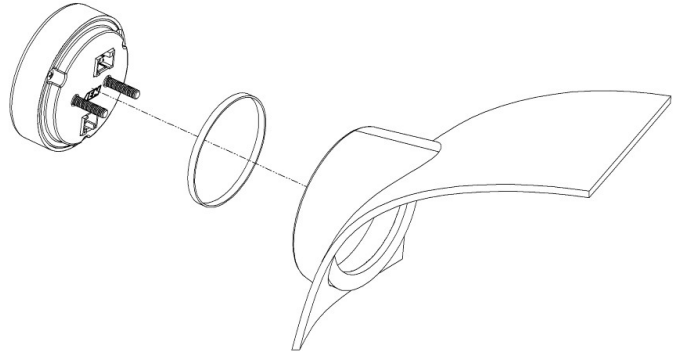

Installation without bracket, using rubber band

A 2-1/6" (52mm) hole is required to mount the X-Series gauge. A bracket and thumbscrews are provided to facilitate installation into a panel or gauge pod. In some cases, the gauge cup may be pushed into a mounting hole causing an interference fit strong enough to retain the gauge; the supplied rubber band may be fit to the gauge to create a tighter fit in mounting holes slightly larger than 52mm. It is, however, recommended that gauges be mounted securely using the supplied bracket to ensure they never become loose and cause a hazard during vehicle operation.

Note: The gauge is not water-proof and should not be installed in a location with exposure to water or snow. Damage caused by water ingress will not be covered under warranty.

AEMnet (CAN bus) Output

WHITE WIRE WITH BLACK STRIPE = AEMnet+ / CANH

GREEN WIRE WITH BLACK STRIPE = AEMnet- / CANL

The AEMnet output is suitable for output to AEM devices such as the AQ-1 data logger or Infinity ECU. The following CAN configuration and message definition information is provided below to facilitate interface with third-party devices.

Bus Termination

All AEMnet/CAN networks must be terminated to have an equivalent of approximately 60 Ohms of resistance. Generally, this means a 120 Ohm resistor connected in parallel to AEMnet+/AEMnet- (or CANH/CANL) at both physical ends of the bus run. The X-Series device does not have any internal termination and is intended to be connected to a pre-existing, properly terminated network. Please refer to the Bosch CAN2.0B specification for further detail.

bit rate	500	kb/sec
format	29	bit ID
transmit rate	20	hz
terminating resistor	none	
endianness	big / Motorola	
DLC	8	

Message ID	0x000A0000
-------------------	-------------------

100ms continuous (10hz)

Byte	Bit	Bitmask	Label	Data Type	Scaling	Offset	Range
0-3	-	-	Latitude (deg)	32 bit float	WGS-84 datum, North is positive	0.0	+90 North to -90 South
4-7	-	-	Longitude (deg)	32 bit float	WGS-84 datum, East is positive	0.0	+180 East to -180 West

Message ID	0x000A0001
-------------------	-------------------

100ms continuous (10hz)

Byte	Bit	Bitmask	Label	Data Type	Scaling	Offset	Range
------	-----	---------	-------	-----------	---------	--------	-------

30-0313 - GPS SPEEDOMETER

0-1	-	-	Ground Speed	16 bit unsigned	0.01 mph/bit	0	0 to 655.35 MPH
2-3	-	-	Altitude	16 bit signed	1 ft/bit	0	-32,768 to 32,767 Feet
4-5	-	-	True Course	16 bit unsigned	0.01 deg/bit	0	0 to 655.35 degrees
6	-	-	Satellites in Use	8 bit unsigned	1	0	0 to 255 Satellites
7	-	-	GPS Valid	8 bit unsigned	0 = N/G, 1 = OK	0	0 to 255

Message ID

0x000A0002

200ms continuous (5hz)

Byte	Bit	Bitmask	Label	Data Type	Scaling	Offset	Range
0	-	-	GPS Valid	8 bit unsigned	1	0	0-255
1	-	-	UTC Year	8 bit unsigned	1	0	0-255 Years
2	-	-	UTC Month	8 bit unsigned	1	0	0-255 Months
3	-	-	UTC Day	8 bit unsigned	1	0	0-255 Days
4	-	-	Reserved	8 bit unsigned	1	0	0-255
5	-	-	UTC Hours	8 bit unsigned	1	0	0-255 Hours
6	-	-	UTC Minutes	8 bit unsigned	1	0	0-255 Minutes
7	-	-	UTC Seconds	8 bit unsigned	1	0	0-255 Seconds

FAQ / Troubleshooting

My gauge just displays just shows "GPS"

"GPS" will be displayed when the GPS receiver is not connected or the gauge is not receiving any data from the GPS receiver. A green LED will be illuminated on the side of the GPS receiver when it is receiving power from the gauge and operational.

My gauge just displays just shows "SA"

"SA" will be displayed when the gauge is receiving data from the GPS receiver but there are fewer than three satellites acquired. It may take up to 35 seconds for a "cold" start.

What pins are used in the connector?

To populate optional extras, use JST P/N SPUD-001T-P0.5 terminals for 22-26 AWG wire.

For support, contact AEM Technical Support at 1-800-423-0046 or gentech@aemelectronics.com.

Specifications

Dimensions	diameter (bezel)	2.40	in
	diameter (cup)	2-1/16	in
	depth (incl. bezel)	0.825	in
	depth (cup only)	0.200	in
Supply Voltage	min	10	VDC
	max	18	VDC
Supply Current (13.8V)	nominal	50.0	mA
Operating Temperature	min	-4 / -20	degF / degC
	max (16V Supply)	185 / 85	degF / degC
GPS	Channels	66	
	Frequency (GPS)	(L1) 1,575	MHz
	Horizontal Position Accuracy	< 3.0 m CEP (SA off)	
	<i>Time To First Fix - TTFF*</i>		
	Hot start	< 1	sec
	Warm	< 34	sec
	Cold	< 35	sec
Notes	*=theoretical minimum values; values in real world may differ		

12 Month Limited Warranty

Advanced Engine Management Inc. warrants to the consumer that all AEM High Performance products will be free from defects in material and workmanship for a period of twelve (12) months from date of the original purchase. Products that fail within this 12-month warranty period will be repaired or replaced at AEM's option, when determined by AEM that the product failed due to defects in material or workmanship. This warranty is limited to the repair or replacement of the AEM part. In no event shall this warranty exceed the original purchase price of the AEM part nor shall AEM be responsible for special, incidental or consequential damages or cost incurred due to the failure of this product. Warranty claims to AEM must be transportation prepaid and accompanied with dated proof of purchase. This warranty applies only to the original purchaser of product and is non-transferable. All implied warranties shall be limited in duration to the said 12-month warranty period. Improper use or installation, accident, abuse, unauthorized repairs or alterations voids this warranty. AEM disclaims any liability for consequential damages due to breach of any written or implied warranty on all products manufactured by AEM. Warranty returns will only be accepted by AEM when accompanied by a valid Return Merchandise Authorization (RMA) number. Product must be received by AEM within 30 days of the date the RMA is issued. UEGO oxygen sensors are considered wear items and are not covered under warranty. Please note that before AEM can issue an RMA for any electronic product, it is first necessary for the installer or end user to contact the EMS tech line at 1-800-423-0046 to discuss the problem. Most issues can be resolved over the phone. Under no circumstances should a system be returned or a RMA requested before the above process transpires. AEM will not be responsible for electronic products that are installed incorrectly, installed in a non-approved application, misused, or tampered with. Any AEM electronics product can be returned for repair if it is out of the warranty period. There is a minimum charge of \$50.00 for inspection and diagnosis of AEM electronic parts. Parts used in the repair of AEM electronic components will be extra. AEM will provide an estimate of repairs and receive written or electronic authorization before repairs are made to the product.