

GFB DV+

Installation Instructions

Part #T9381



+61 2 9534 0099

sales@gfb.com.au

www.gfb.com.au

facebook.com/GFBturbo

instagram.com/gofastbits



TURBO MANAGEMENT SYSTEMS



PERFORMANCE WITHOUT COMPROMISE

IMPORTANT! All GFB pistons are checked for fitment and tolerance before shipment. Please do not drop the GFB piston onto a hard surface as this may cause (invisible) damage that could result in boost leaks or sticking.

WICHTIG! Alle Kolben wurden vor Versand auf Freigängigkeit geprüft. Bitte achten Sie bei der Montage darauf, dass *der Kolben nicht auf den Boden fällt*, da dieser schon bei kleinster (evtl. Nicht sichtbarer) Beschädigung zur Undichtigkeit oder Kolbenklemmen führen kann!

INSTALLATION

Locate the factory diverter valve. It will either be mounted directly on the turbo compressor cover, or it can be mounted remotely at the front of the engine bay on cars like the Mk6 Golf R.

Unclip the wiring connector () from the top of the solenoid coil – note there is a small locking tab that needs to be pulled in the same direction (as indicated by the white arrow opposite) as you pull the connector to release it.



Unscrew the 3 mounting screws and remove the factory diverter valve from the car.

Hold the piston of the DV+ assembly with your finger, then remove and discard the plastic assembly tab. With this tab removed, take care not to drop the piston, as it could fall out of the body if tipped up.

Apply some engine oil to the piston skirt (NOT grease or other heavy lubricants). Note that regular maintenance or re-lubrication is NOT required after installation.

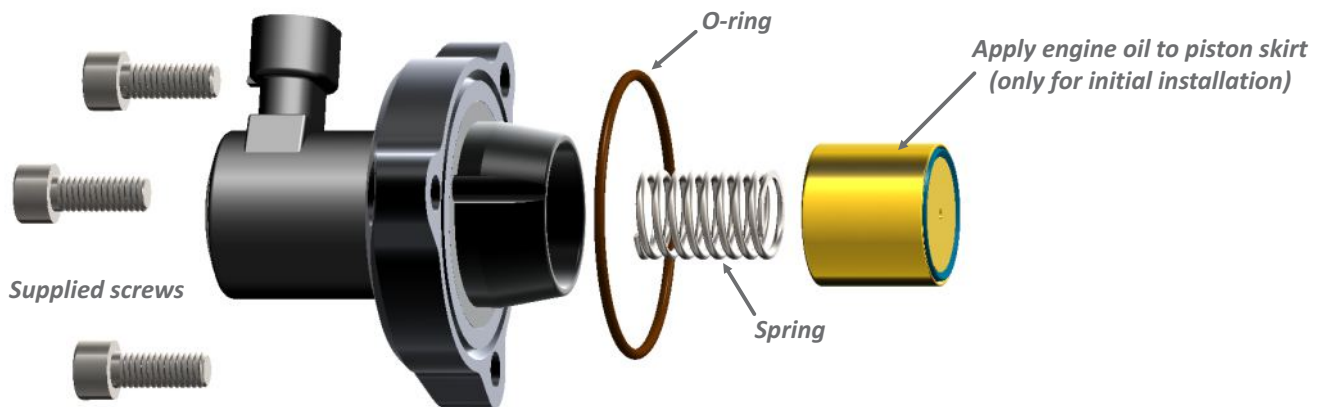

Assemble the DV+ as shown above, then install onto the factory mounting location using the supplied screws, **making sure to hold the piston during this process to prevent it from falling out.**

The bolt pattern on the DV+ body is symmetrical, so you are free to choose whichever orientation you prefer, and the solenoid can be rotated by hand to allow connector to face the most appropriate direction for your application.

Use the supplied “plug-and-play” adaptor loom to connect the DV+ to the vehicle’s diverter valve connector, and ensure the loom is protected from abrasion and heat.

Replace any other parts that were removed during installation.



WHAT TO EXPECT FROM YOUR DV+

Sound:

The DV+ is NOT an atmosphere-venting blow off valve and is not designed to make a “blow-off” sound. It fully recirculates the vented air to the turbo intake in the same way as the OEM diverter. The venting sound may differ slightly from the factory diverter under some conditions, but if you hear a loud fluttering sound when lifting off the throttle from full boost, that indicates the valve is not opening correctly and you should contact our tech support using the details on the next page.

Maintenance:

There are many online discussions on the topic of regular maintenance or lubrication of a DV+. The fact is that periodic maintenance or re-lubrication of the DV+ for correct operation or longevity is NOT required! Simply install it and forget about it.

Similar to an engine breaking in, once the DV+ has been used for about a week the microscopic machining high spots are flattened and smoothed, after which it will continue operation almost indefinitely without wear, irrespective of lubrication.

Longevity:

The DV+ will outlast any version of the factory diverter, especially on tuned engines. If you've ever replaced a factory diverter, chances are it won't be your last. Fitting a DV+ is good insurance and pays for itself after one or two factory diverter replacements.

Boost holding:

There are a number of revisions of factory diverter valves, each with their shortcomings. The diaphragm types typically seal well, until they begin to fail - which is almost assured on a tuned engine. The piston-type revision D and later model C valves are not as fragile, but their ability to seal ranges dramatically from average to terrible, even when brand new.

The DV+ will seal properly even up to 50psi, ensuring all of your hard-earned boost gets to the engine. Of course, the performance benefits you notice from the driver's seat will depend entirely on the condition of the factory diverter you replace. For example, if your factory valve is not (yet) leaking significantly, there will be no change to your peak boost.

However, if your factory diverter is leaking only a small amount, a DV+ may show the same peak boost, but with an improvement in the amount of boost held to redline. If your factory valve is leaking significantly, fitting the DV+ will result in higher peak boost pressure, as well as less drop-off at high RPM.

Throttle response:

Unlike the factory diverter, when you lift off the throttle the DV+ piston only opens as much as required to vent the resulting pressure spike. Once that's done, the DV+ piston will progressively begin to close to preserve as much residual boost pressure as possible. This means that when you re-open the throttle soon after lifting off, the DV+ can help recover boost faster.

TECH SUPPORT

Just installed your shiny new DV+ and something doesn't seem right? Do you have a question about the product? Have you heard conflicting information and need some clarity?

We want you to get the best advice, first time. No-one has as much experience with these products as our own engineers, so make us your first point of contact!

Head to www.gfb.com.au/contact-us to get in touch, or use the QR code:



WARRANTY

WARNING:

GFB recommends that only qualified motor engineers fit this product. GFB products are engineered for best performance, however incorrect use or modification may cause damage to or reduce the longevity of the engine/drive-train components.

GFB LIFETIME WARRANTY:

Our commitment to quality means that when we put our name to something, we are also staking our reputation on it. That's why we back our products with the best warranty in the business!

You should expect a lifetime of use from a well-engineered product, so if your GFB product fails as a result of defective materials or faulty workmanship whilst you remain the original owner, we will repair or replace it (limited only to the repair or replacement of GFB products provided they are used as intended and in accordance with all appropriate warnings and limitations. No other warranty is expressed or implied).

If a fault occurs as a result of usage outside of the terms of the warranty, or you are not the original owner, fear not, we can still help you. You should never need to throw a GFB product away, as spare parts are available and won't cost the earth.