

GFB Hybrid

Part #T9210



+61 2 9534 0099

sales@gfb.com.au

www.gfb.com.au

facebook.com/GFBturbo

instagram.com/gofastbits

GFB
GO FAST BITS

TURBO MANAGEMENT SYSTEMS



PERFORMANCE WITHOUT COMPROMISE

Installation

1) Access to the factory diverter valve is made easier with the removal of the airbox. To do this, remove the two plastic clips on the intake (press the centre pin in to release ⇨⇨), hose clamp (⇨⇨), and the 3 bolts (⇨⇨). Carefully remove it from the car and set aside.

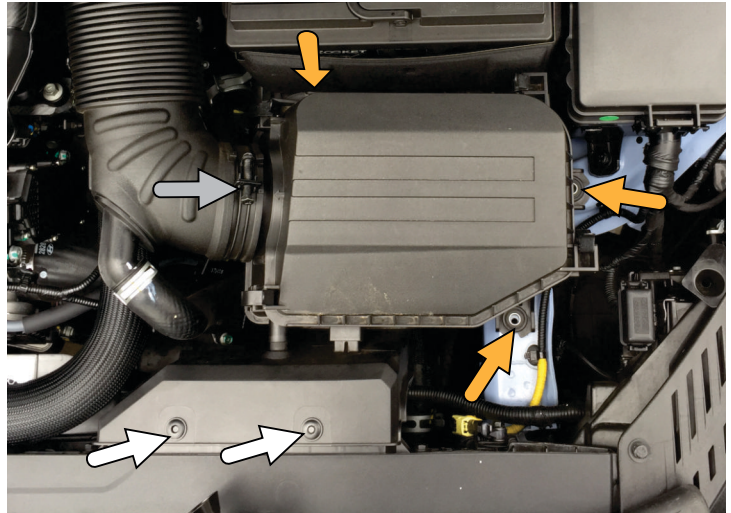

2) Before unbolting the factory valve, it is easiest to first remove the recirc hose while the valve is still solidly mounted (this hose is quite tight and needs some wiggling persuasion). Then remove the factory valve from the car using a 10mm socket for the 4 screws.

3) Ensure the brown o-ring is installed in the groove on the underside of the Hybrid valve, then install it back in the factory location using the supplied longer screws and 5mm hex key.

4) Fit the recirc and vacuum hoses onto the Hybrid, and replace the clamps.

5) Re-install the airbox in the reverse order of removal.



Adjusting the Spring Pre-Load

The spring pre-load **DOES NOT** need to be adjusted to suit different boost pressure. **All GFB valves will stay shut** under full throttle conditions **regardless** of boost pressure or spring pre-load.

Because Hyundai uses an ECU-controlled solenoid valve to switch the top port of the BOVs from boost to vacuum when it requires them to open, the conditions under which the BOVs vent are largely determined by the ECU. However, the duration of the sound and how easily they blow off is controlled by the spring pre-load.

The ECU typically triggers the solenoid immediately on throttle lift off (even if the throttle is only slightly lifted), but usually only above a certain RPM and load. Therefore, the valves may appear to vent at odd times, or at low load it may appear not to vent at all, this is normal and is determined by the ECU.

Since there is no MAF sensor on these cars, the ECU is completely unaffected by atmosphere venting or spring pre-load, and therefore the spring pre-load can simply be set to your preference to control how easily the valve blows off when you lift off the throttle.

The screw in the centre of the Hybrid cap is the spring adjuster, which requires a 5mm hex key (supplied). The softest spring setting is achieved when the top of the adjustment screw is 3mm above the head of the valve as shown opposite. Do not set the screw to a position higher than this.

A good starting position for the spring pre-load is to set the screw level with the top of the valve. Take the car for a drive, and take note of how easily the valve vents when you lift off. Making the spring softer will allow the valve to open easier and vent longer, and increasing the pre-load means you will need to drive the car harder (i.e. more boost) before you start to hear the valve venting, and the blow-off sound will be shorter in duration.

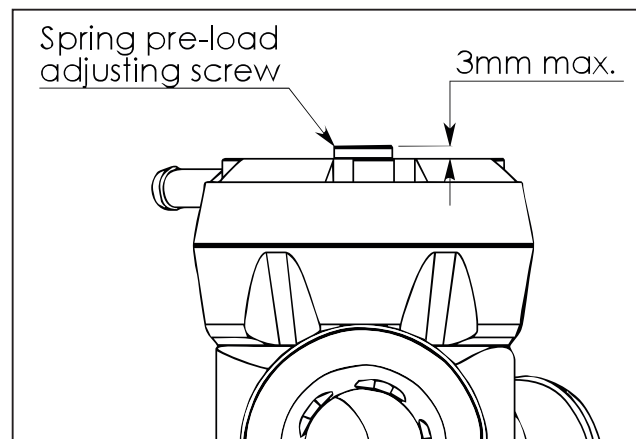

Changing the Sound

The GFB Hybrid is supplied with a plug set that allows you to configure the valve in 3 different ways, depending on your preference.

Because these cars have no MAF sensor, the ECU is completely unaffected by atmosphere venting, so you can set the valve up however you like.

For silent, fully recirculated operation, leave the recirc hose connected and swap the trumpet for the threaded plug.

For full atmosphere venting and maximum noise, plug the recirc hose with the supplied hose plug, and install the screw-in plug in place of the Hybrid recirc outlet.

For 50/50 venting and a moderate sound, keep the recirc hose connected and the trumpet installed.

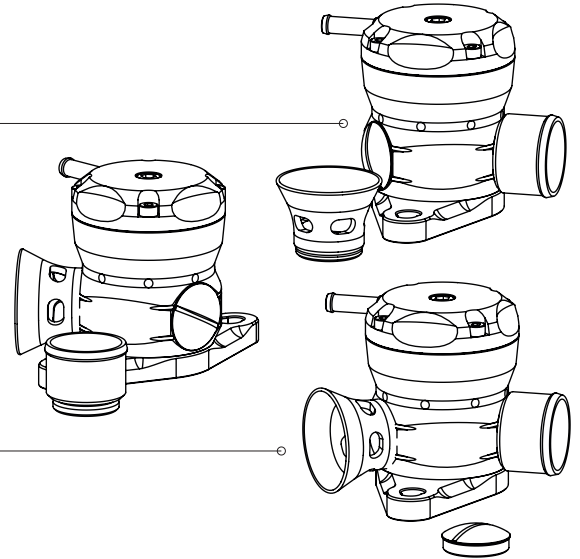

Leak Testing

If you or your tuner pressure test your car's intake system as part of routine maintenance, or to troubleshoot a problem, please note that it is common to detect a false leak from a Hybrid BOV (or indeed any type of dual-port BOV), which does not necessarily indicate a fault or boost leak. This is due to the test method (even when done "correctly") and is explained in detail in the tech articles and video below:

www.gfb.com.au/tech/tech-articles/15-smoke-testing-boost-leaks

www.gfb.com.au/images/tech-articles/GFB_DP_Diverter%20leak.pdf

WARNING: GFB recommends that only qualified motor engineers fit this product. This product is intended for racing use only, and it is the owner's responsibility to be aware of the legalities of fitting this product in his or her state/territory regarding noise, emissions and vehicle modifications. GFB products are engineered for best performance, however incorrect use or modification of factory systems may cause damage to or reduce the longevity of the engine/drive-train components.

GFB Limited Lifetime Warranty:

We live in a throw-away society, conditioned by cheap products and built-in obsolescence to expect eventual failure and discard something when it stops working or is superseded. However, pride in workmanship and our commitment to quality means that when we put our name to something, we are also staking our reputation on it.

That is why we back our products with the best Warranty in the business! You should expect a lifetime of use from a well-engineered product, so if your GFB product fails as a result of defective materials or faulty workmanship whilst you remain the original owner, we will repair or replace it (limited only to the repair or replacement of GFB products provided they are used as intended and in accordance with all appropriate warnings and limitations. No other warranty is expressed or implied).

If a fault occurs as a result of usage outside of the terms of the warranty, or you are not the original owner, fear not, we can still help you. You should never need to throw a GFB product away, as spare parts are available and won't cost the earth.