

GFB Respons

Part #T9019



+61 2 9534 0099

sales@gfb.com.au

www.gfb.com.au

facebook.com/GFBturbo

instagram.com/gofastbits



TURBO MANAGEMENT SYSTEMS



PERFORMANCE WITHOUT COMPROMISE

Configuring Your Valve

The T9019 Respons kit is intended for custom installations where the valve is to be rigidly mounted to your aluminium or stainless steel intercooler piping using a v-clamp system.

PLEASE NOTE: This kit comes with only the valve and v-clamp. To finish the installation, you will need to purchase the appropriate weld-on flange to suit your intercooler pipe material, and an outlet fitting to suit your recirc hose internal diameter.

Weld on flanges available:

Part #5352 - 6061 Aluminium, suits aluminium intercooler piping

Part # 5353 - 304 Stainless Steel, suits steel or stainless steel intercooler piping

Outlet sizes available:

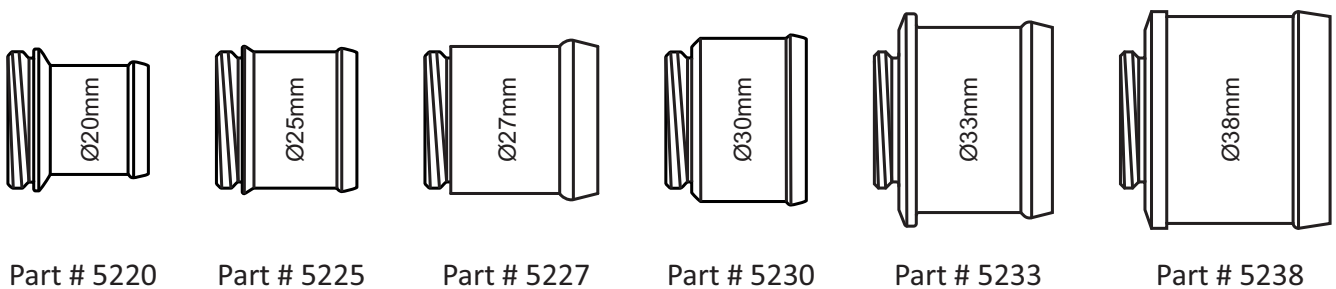

Installation

1) Find a suitable location for the Respons on the intercooler piping between the turbo outlet and the throttle body.

NOTE: it is possible to mount the valve on either side of the intercooler, there is no measurable performance difference between either location.

2) Ensure you have the correct v-clamp flange to suit your intercooler pipe material, then weld it into place.

3) Clamp the Respons onto the flange, then connect the recirc hose (if fitted) to the Respons outlet.

4) Connect the vacuum nipple on the top of the Respons to a suitable manifold vacuum source (after the throttle body), using vacuum hose of at least 4mm I.D. It is preferable to use a single, dedicated vacuum source for the Respons, with a hose as short as practical to ensure rapid response from your GFB BOV. DO NOT CONNECT THE BOV VACUUM HOSE TO BOOST CONTROL, FUEL PRESSURE REGULATOR OR BRAKE BOOSTER HOSES.

5) If necessary, the cap can be rotated so the vacuum nipple points in a different direction. Simply unscrew the 4 cap screws and rotate the cap to a new position, then reinstall the screws.

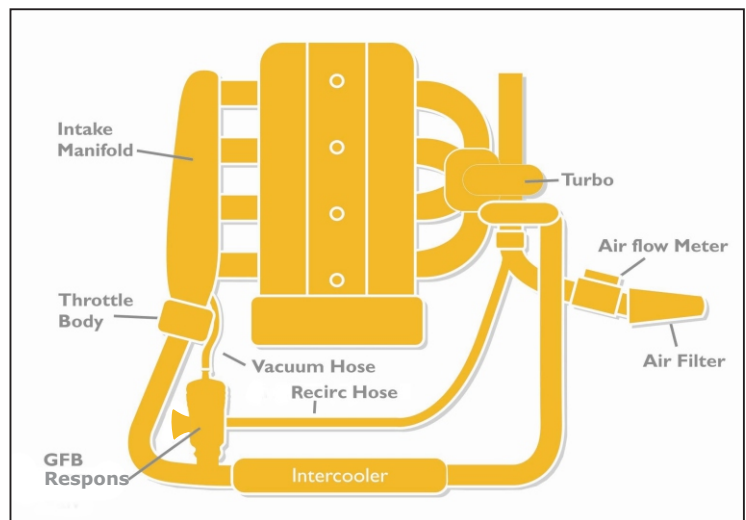

Adjusting the Spring Pre-Load



Scan the QR code for a video tutorial of setting the spring pre-load:

The spring pre-load DOES NOT need to be adjusted to suit different boost pressure. All GFB valves will stay shut under full throttle conditions regardless of boost pressure or spring pre-load.

Rather, the spring pre-load affects how easily the valve opens when you lift the throttle, and how long it stays open when it vents.

The screw in the centre of the head is the spring adjuster. Use the supplied 5mm hex key to make adjustments.

The softest spring setting is achieved when the top of the adjustment screw is 3mm above the head of the valve (shown opposite). Do not exceed this setting as you run the risk of the screw working loose and falling out.

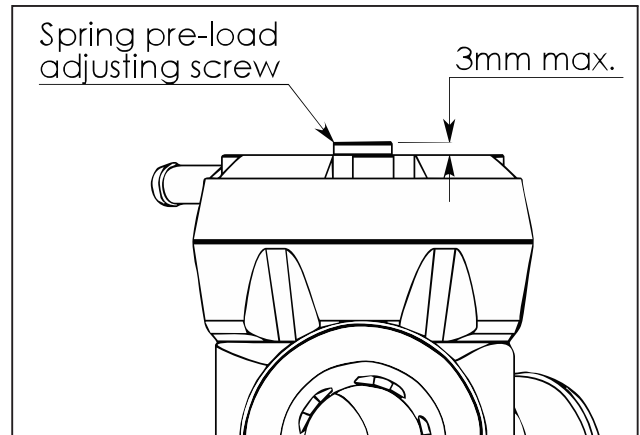

The following steps will guide you to the optimum spring range. For cars with a MAF sensor, it is important to find the correct setting to prevent idling issues. There is no magic setting that suits every car, and some cars may be happy within a large range of spring adjustment, others may need a little more experimentation to find their happy place.

Do not be afraid to experiment with the spring pre-load adjustment, you can't cause any damage by doing so, and getting the setting right to suit your car can help to optimise throttle response.

Put simply, if the car has idle or stalling issues, backfires or hesitates, the spring is too soft. If fluttering is heard when lifting off from medium to high boost, the spring is too hard.

- Set the spring to the softest setting, and move the noise adjusting ring to at least 50% atmosphere venting so you can hear when the valve vents
- With the engine warm and A/C off, give it a good hard rev. The valve should blow off with a short "whoosh"
- If the engine stumbles, stalls, or generally struggles to return smoothly to idle, it means the valve is venting too long. Turn the adjustment screw clockwise one turn at a time until the engine returns smoothly to idle after revving
- Now take the car for a drive. Accelerate enough to build some boost, then lift off and clutch in, letting the engine come back to idle. This is the driving condition most likely to cause the idle to dip, so make any further increases in spring pre-load to ensure no idle issues under these conditions.
- If the spring pre-load alone is not able to ensure smooth idle, reduce the venting bias so that more air is recirculated (see next page)
- If a loud flutter is heard when lifting off sharply after accelerating hard at high RPM, wind the adjustment screw in the "-" direction one turn at a time until the noise disappears. Note that it is not uncommon to hear a slight fluttering at low RPM under certain conditions. This is a result of the different way in which this valve operates compared to the factory unit, and is perfectly normal and is not detrimental

Adjusting the Sound

The unique patented venting bias adjustment feature on the GFB Respons lets you vary the amount of air vented to atmosphere or recirc, thereby changing the volume of the sound.

Turning the venting bias adjuster fully clockwise opens the trumpet port and gives the loudest sound, whilst setting it fully anti-clockwise results in 100% recirculation venting, which is the same as the stock valve and is the quietest

operation (you may still hear the recirc venting if you have an aftermarket intake fitted). You can set the adjustment anywhere in between for a variable venting ratio and to control the sound volume.

If you want a different sound, the GFB Whistling trumpet (part #5702) can be purchased separately. It changes the venting sound from a “whoosh” to a high-pitch whistle.

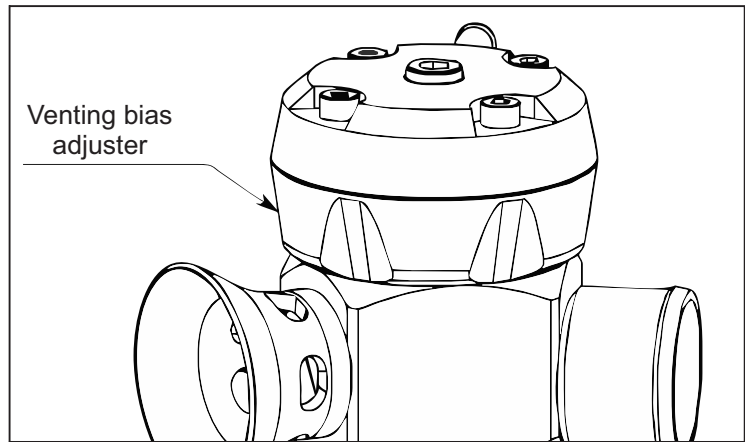

Warranty

WARNING:

GFB recommends that only qualified motor engineers fit this product. GFB products are engineered for best performance, however incorrect use or modification may cause damage to or reduce the longevity of the engine/drive-train components.

GFB LIFETIME WARRANTY:

Our commitment to quality means that when we put our name to something, we are also staking our reputation on it. That's why we back our products with the best warranty in the business!

You should expect a lifetime of use from a well-engineered product, so if your GFB product fails as a result of defective materials or faulty workmanship whilst you remain the original owner, we will repair or replace it (limited only to the repair or replacement of GFB products provided they are used as intended and in accordance with all appropriate warnings and limitations. No other warranty is expressed or implied).

If a fault occurs as a result of usage outside of the terms of the warranty, or you are not the original owner, fear not, we can still help you. You should never need to throw a GFB product away, as spare parts are available and won't cost the earth.

TECH SUPPORT:

We want you to get the best advice, first time. That's why our engineers are available to answer any technical questions you may have.

Head to www.gfb.com.au/contact-us to get in touch.