

# E-WM05-0000116

## MOUNTING INSTRUCTION



### IMPORTANT! READ THIS FIRST!

Installation of shock absorbers or other suspension components requires special tools and expert knowledge. Accordingly, installation of all BILSTEIN products must be performed by a professional automotive suspension technician.

When replacing other brands, BILSTEIN shock absorbers or other suspension components should always be installed as a set. All BILSTEIN products must only be used for the specific, intended application as indicated in the application guide. **Any use of any BILSTEIN product other than for its intended use may result in serious bodily injury or death.**

Always use a chassis hoist for the installation of BILSTEIN products and make certain that the raised vehicle is securely attached to the hoist and/or supported to prevent the vehicle from slipping, falling, or moving during the installation process.

**If you install any BILSTEIN product without the necessary special tools, expertise, and chassis hoist, you may subject yourself to the risk of serious bodily injury or death.**

BILSTEIN shock absorbers are gas-filled and are highly pressurized.

- Never place any BILSTEIN shock absorbers in a vise or use a clamp on any BILSTEIN shock absorber.
- Never apply heat near any BILSTEIN shock absorber.
- Never attempt to open or repair any BILSTEIN product, in order to prevent **serious bodily injury or death.**

Any attempt to misuse, misapply, modify, or tamper with any BILSTEIN suspension product voids any warranty and **may result in serious bodily injury or death.**

While installing any BILSTEIN product:

- Do not use impact tools for loosening or tightening fasteners, because this may destroy the screw threads.
- Self-locking fasteners must only be used **once!**
- Reuse original equipment components only if they are in good condition, otherwise replace them with new components.
- Never remove the slight film of oil on the shock absorber piston rod and seal.
- All mounting fasteners for shock absorbers and other suspension components must be securely tightened before tension is placed on the suspension system, unless otherwise specified in the manufacturer's service manual or in this instruction.

After installing any BILSTEIN product:

- The suspension caster and camber must be checked and/or adjusted to comply with the vehicle manufacturer's specifications.
- The (load dependent) brake compensator and the anti-lock brake system must be checked and/or reset to comply with the vehicle manufacturer's specifications.
- The headlight aim must be checked and adjusted. Or, if applicable, adaptive headlights must be checked and recalibrated to comply with the vehicle manufacturer's specifications.
- If applicable, any/all Advanced Driver Assistance Systems (ADAS) must be checked and recalibrated to comply with the vehicle manufacturer's specifications.

### **CAUTION for COILOVER TYPE SUSPENSIONS!!!**

**If disassembling a coilover type suspension, refer to the vehicle manufacturer's service manual for proper procedures. The coil spring is preloaded and must be compressed with a spring compressor to release load before the upper mount is disassembled. Failure to follow the vehicle manufacturer's procedures may cause serious injury or death, and may damage the vehicle.**

### **IMPORTANT!!!**

**This BILSTEIN product may or may not be compatible with non-BILSTEIN aftermarket products and/or vehicle modifications. It is the responsibility of the professional automotive suspension technician performing the installation to identify any non-OEM components and/or modifications on the vehicle that may interact with the suspension system. These must be evaluated for any potential physical static or dynamic interference with and/or effect on the function of this BILSTEIN product.**

# E-WM05-0000116 MOUNTING INSTRUCTION



This instruction is for both front left (driver) 41-322673 and front right (passenger) 41-322697 B8 8112 shocks. A step by step process is shown with images of the right front. The left front is a mirror image of the right front. Skip to the end to see final result. A bill of materials of the included mounting part kits are shown below and on the following page.

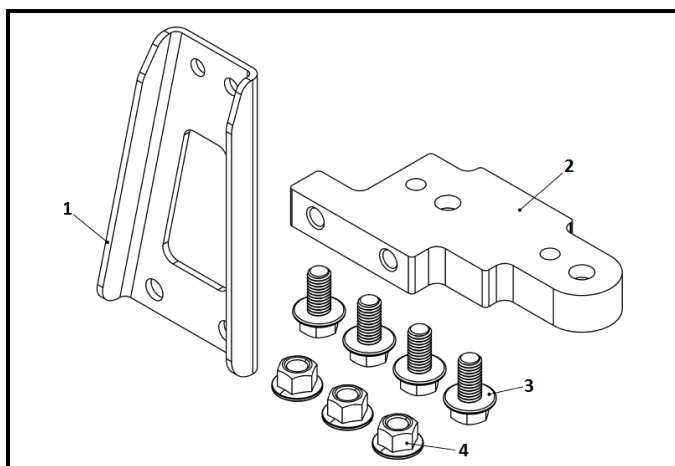

### Bill of Materials

Item #	Description	Qty
1	Reservoir Support Plate, Left	1
2	Sway Bar Spacer, Left	1
3	Flange Head Cap Screw, M10x1.5, L=20mm, 15mm Hex Head	4
4	NUT, M10x1.5mm, 15mm Hex Head	3

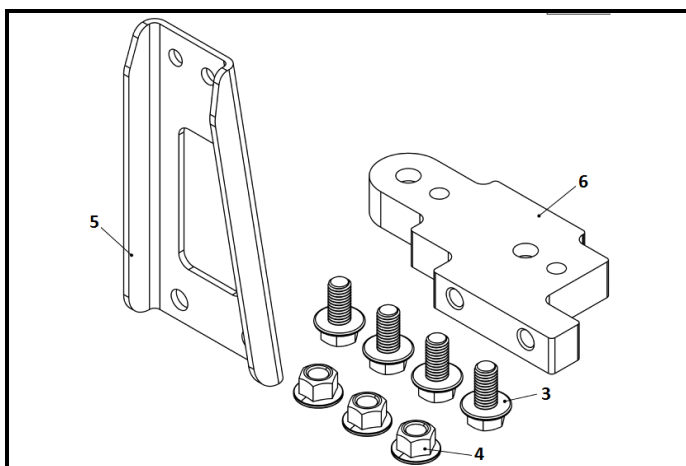

### Bill of Materials

Item #	Description	Qty
5	Reservoir Support Plate, Right	1
6	Sway Bar Spacer, Right	1
3	Flange Head Cap Screw, M10x1.5, L=20mm, 15mm Hex Head	4
4	NUT, M10x1.5mm, 15mm Hex Head	3

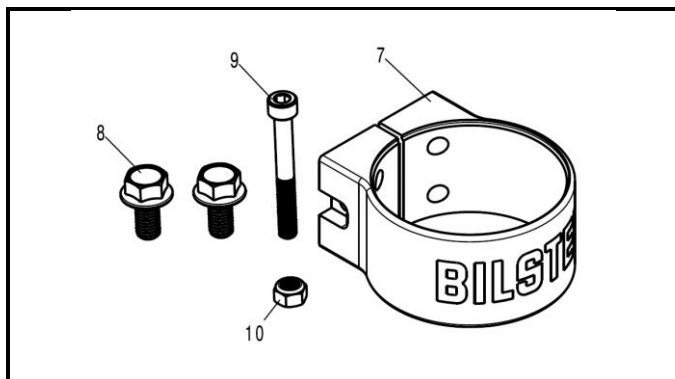

### Bill of Materials

Item #	Description	Qty
7	Reservoir Clamp	1
8	Flange Head Cap Screw, M8x1.25, L=16mm, 13mm Hex Head	2
9	SS Socket Head Cap Screw, M6x1, L=50mm, 5mm Hex	1
10	Nylock Nut, M6x1	1

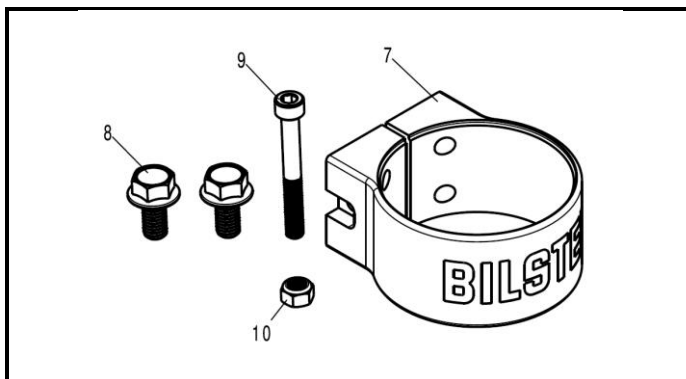

### Bill of Materials

Item #	Description	Qty
7	Reservoir Clamp	1
8	Flange Head Cap Screw, M8x1.25, L=16mm, 13mm Hex Head	2
9	SS Socket Head Cap Screw, M6x1, L=50mm, 5mm Hex	1
10	Nylock Nut, M6x1	1

# E-WM05-0000116 MOUNTING INSTRUCTION

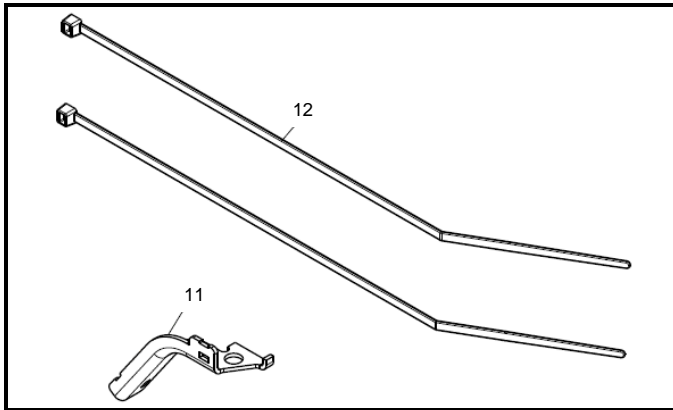

<b>Bill of Materials</b>		
Item #	Description	Qty
11	ABS Relocation Bracket, Left	1
12	Zip Tie	2

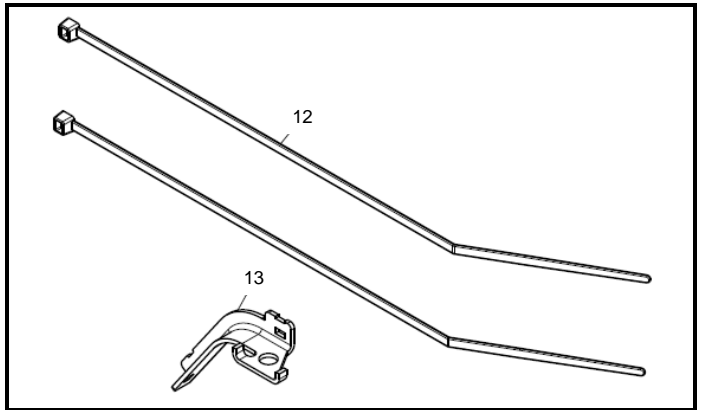

<b>Bill of Materials</b>		
Item #	Description	Qty
13	ABS Relocation Bracket, Right	1
12	Zip Tie	2

# E-WM05-0000116

## MOUNTING INSTRUCTION



It is normal to hear a slight audible clicking noise during compression and rebound strokes in the B8 8112 shocks, most notably during low velocity events. This is due to the internal pistons engaging each other creating the position sensitive compression and rebound zones.

### **B8 8112 shock installation procedure:**

- A. Remove the existing shock module from the vehicle following all procedures in the vehicle manufacturer's service manual. Save the lower shock bolt and nut as they will be used later.
- B. Before installing the B8 8112 shocks on the vehicle check if they are set at the desired lift height. The pre-set lift heights are different for each drive-type, engine, cab, bed, and year range. Use the tables below to determine if the pre-set lift height is what is desired:

4WD V6, Double Cab, 6' Bed	
2016+	2005-2015
1.4" lift	1.9" lift

4WD V6, Double Cab, 5' Bed	
2016+	2005-2015
1.5" lift	2.2" lift

4WD V6, Access Cab	
2016+	2005-2015
1.6" lift	2.1" lift

4WD 4cyl, Access Cab
2016+
1.6" lift

RWD, 6 lug, V6, Double Cab, 6' Bed	
2016+	2005-2015
1.7" lift	2.1" lift

RWD, 6 lug, V6, Double Cab, 5' Bed	
2016+	2005-2015
2" lift	2.3" lift

RWD, 6 lug, V6, Access Cab	
2016+	2005-2015
2.2" lift	2.6" lift

RWD, 6 lug, 4cyl, Access Cab
2016+
Do not use

Note that the pre-set lift height is too high for a 2016+ RWD, 6 lug, 4cyl, Access Cab and must be adjusted before installing on vehicle. Proceed to Step D for instructions on how to lower spring seat.

- C. If the lift height listed above is not what is desired, proceed to Step D. Otherwise, go to Step K.
- D. Break the spring seat lock ring loose with the supplied spanner wrenches. Refer to Figure 1 on the next page.
- E. Note the clocking of the lower mount relative to the studs on the upper mount (important for reassembly).
- F. Using an appropriate spring compressor, compress the spring until it can be rotated freely by hand. Then, spin the spring seat up or down depending on what the desired lift height is. Note that the right side (passenger) should always be approximately 5/16" lower than the left side (driver) to compensate for the inherent vehicle lean. The following tables show what the allowable lift height ranges are for each truck configuration and give a few points of reference for the relationship between the amount of exposed thread and the estimated lift height. They are listed for stock weight vehicles.

# E-WM05-0000116 MOUNTING INSTRUCTION

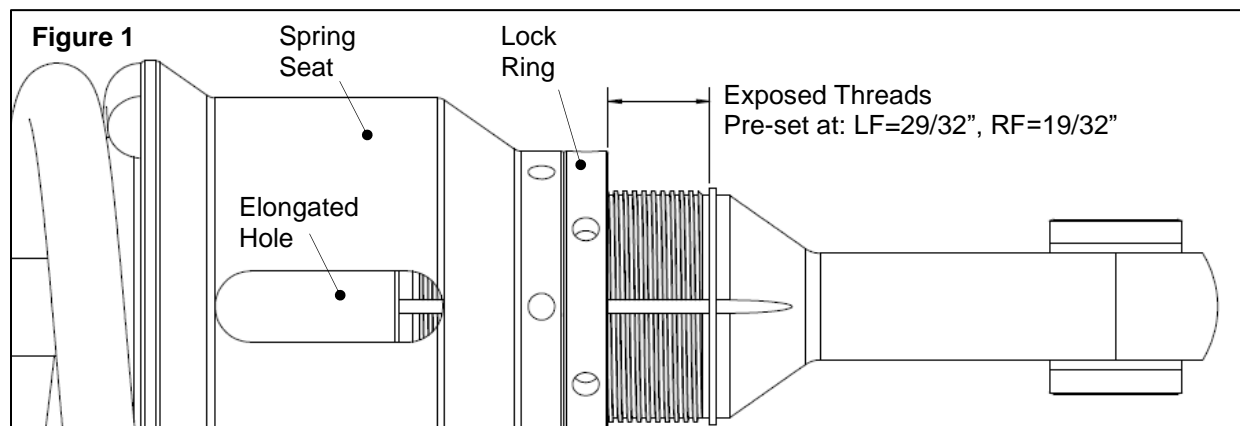

**DO NOT EXCEED MAX LIFT HEIGHT LISTED FOR YOUR VEHICLE**

4WD V6, Double Cab, 6' Bed			
Exposed Threads		B8 8112 Typical Lift Heights**	
Left Front	Right Front	2016+	2005-2015
1 9/32" (very top)	31/32"	2" lift	2.5" lift
31/32"	21/32"	1.5" lift	2" lift
5/8"	11/32"	1" lift	1.5" lift
5/16"	0"	0.4" lift	0.9" lift

4WD V6, Double Cab, 5' Bed			
Exposed Threads		B8 8112 Typical Lift Heights**	
Left Front	Right Front	2016+	2005-2015
1 7/32"	29/32"	2" lift	2.6" lift
29/32"	19/32"	1.5" lift	2.2" lift
5/8"	5/16"	1" lift	1.7" lift
5/16"	0"	0.5" lift	1.3" lift

4WD V6, Access Cab			
Exposed Threads		B8 8112 Typical Lift Heights**	
Left Front	Right Front	2016+	2005-2015
1 1/8"	13/16"	2" lift	2.5" lift
7/8"	9/16"	1.5" lift	2" lift
19/32"	9/32"	1" lift	1.5" lift
5/16"	0"	0.6" lift	1.1" lift

4WD 4cyl, Access Cab		
Exposed Threads		B8 8112 Typical Lift Heights**
Left Front	Right Front	2016+
1 1/8"	13/16"	2" lift
7/8"	9/16"	1.5" lift
19/32"	9/32"	1" lift
5/16"	0"	0.6" lift

RWD, 6 Lug, V6, Double Cab, 6' Bed			
Exposed Threads		B8 8112 Typical Lift Heights**	
Left Front	Right Front	2016+	2005-2015
1 3/32"	25/32"	2" lift	2.4" lift
27/32"	17/32"	1.6" lift	2" lift
9/16"	1/4"	1.2" lift	1.6" lift
5/16"	0"	0.8" lift	1.2" lift

RWD, 6 Lug, V6, Double Cab, 5' Bed			
Exposed Threads		B8 8112 Typical Lift Heights**	
Left Front	Right Front	2016+	2005-2015
1"	11/16"	2.2" lift	2.5" lift
21/32"	11/32"	1.6" lift	2" lift
5/16"	0"	1" lift	1.5" lift

RWD, 6 Lug, V6, Access Cab			
Exposed Threads		B8 8112 Typical Lift Heights**	
Left Front	Right Front	2016+	2005-2015
29/32"	19/32"	2.2" lift	2.6" lift
5/8"	5/16"	1.7" lift	2.2" lift
5/16"	0"	1.2" lift	1.7" lift

RWD, 6 Lug, 4cyl, Access Cab		
Exposed Threads		B8 8112 Typical Lift Heights**
Left Front	Right Front	2016+
19/32"	9/32"	2.2" lift
5/16"	0"	1.7" lift

# E-WM05-0000116

## MOUNTING INSTRUCTION



\*\* Lift heights indicated are typical. Actual lift height is influenced by which factory suspension the vehicle is equipped with and its condition; optional equipment and accessories on your vehicle, and other vehicle modifications such as replacement coil springs, wheel and tire combinations, etc.

Modifying/lifting the suspension to your vehicle may raise its center of gravity and may make it more susceptible to loss of control and/or rollover, which may result in death or serious injury. We strongly recommend that you offset the loss of rollover resistance as much as possible by increasing tire track width, and that you equip the vehicle with a functional roll bar and cage system.

Wear seat belts and shoulder harnesses at all times, and avoid situations where a side rollover may occur.

NOTE: if you exceed the recommended spring seat adjustment range (exposed thread dimension) for your vehicle, make sure to measure the shock at ride height as shown below after the install. This is needed to ensure there is at least 2" of droop travel from static ride height and so the stiffer rebound zone is not being engaged at ride height.

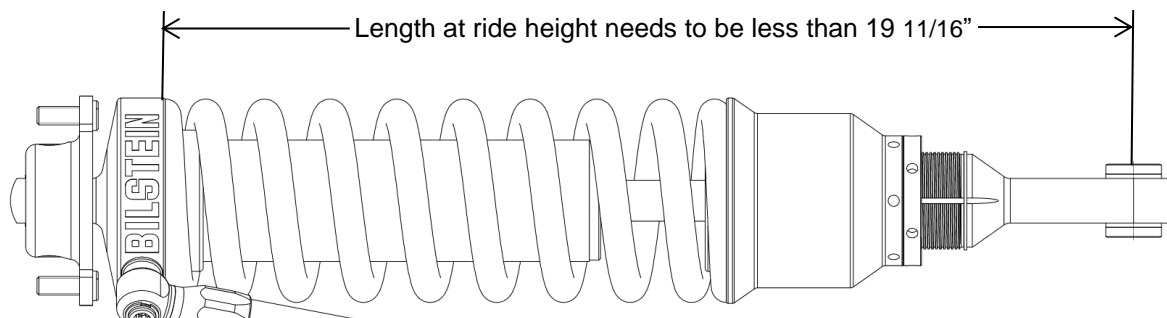

Left Front (driver) depicted

- G. Before finalizing the desired lift height, position the elongated hole in the spring seat so it will face inboard once installed on the vehicle.
- H. Once the desired lift height is set, tighten lock ring against spring seat using supplied spanner wrenches.

**Torque lock ring to spring seat 37 ft-lb (50 Nm).**

- I. Rotate the lower shock mount so it is aligned with the upper mount studs as noted in step E.
- J. Slowly release the spring compressor.

# E-WM05-0000116 MOUNTING INSTRUCTION



- K. Disconnect the sway bar bolts holding sway bar to frame (2 per side) with a 14mm socket and drop the sway bar as shown in the images below. Save these bolts as they will be used to mount the new sway bar spacers later.



- L. Install the shocks onto the vehicle as shown in the image below. Use the 6 supplied nuts and a 15mm socket to attach the upper mount (3 per side, BOM item #4). Leave reservoir hanging temporarily. **Torque supplied upper mount nuts to 33 ft-lb (45 Nm).**



- M. Attach the lower shock mount with the OE shock bolt and nut that was removed in Step A (1 per side). **Torque lower OE shock bolt and nut to service manual specification.**

# E-WM05-0000116

## MOUNTING INSTRUCTION



- N. Apply non-permanent thread locker on the end of each of the screw threads of the OE sway bar bolts that were removed in Step K. Then place these bolts (2 per side) through the counterbored holes in the supplied sway bar spacer (BOM item #6) and thread into the threaded holes in the frame using a 14mm socket as shown in the image below.  
**Torque OE sway bar bolts to service manual specification.**





# E-WM05-0000116 MOUNTING INSTRUCTION



- O. Apply non-permanent thread locker on the end of each of the screw threads of the 4 supplied M10 Flange Head Cap Screws (BOM item #3). Then place these screws (2 per side) through the holes in the OE sway bar bracket and thread into the threaded holes in the supplied sway bar spacer with a 15mm socket as shown in the 2 images below.  
**Torque supplied M10 Flange Head Cap Screws to 37 ft-lb (50 Nm).**



# E-WM05-0000116

## MOUNTING INSTRUCTION



- P. Apply non-permanent thread locker on the end of each of the screw threads of the 4 supplied M8 Flange Head Cap Screws (BOM item #8). Then place these screws (2 per side) through the holes in the supplied reservoir support plate (BOM item #5) and thread into the threaded holes in the supplied reservoir clamp (BOM item #7) as shown in the depictions below using a 13mm socket (2 per side). **Torque supplied M8 Flange Head Cap Screws to 18 ft-lb (25 Nm).**
  
- Q. Place the Socket Head Cap Screw (BOM item #9) (1 per side) up through the pinch bolt hole in the reservoir clamp as shown in the depictions below and thread into the M6x1 Nylock Nut (BOM item #10) (1 per side). Thread it in enough so the Socket Head Cap Screw and Nylock Nut won't fall out, but loose enough so you can still slide the clamp onto the reservoir in the next step.

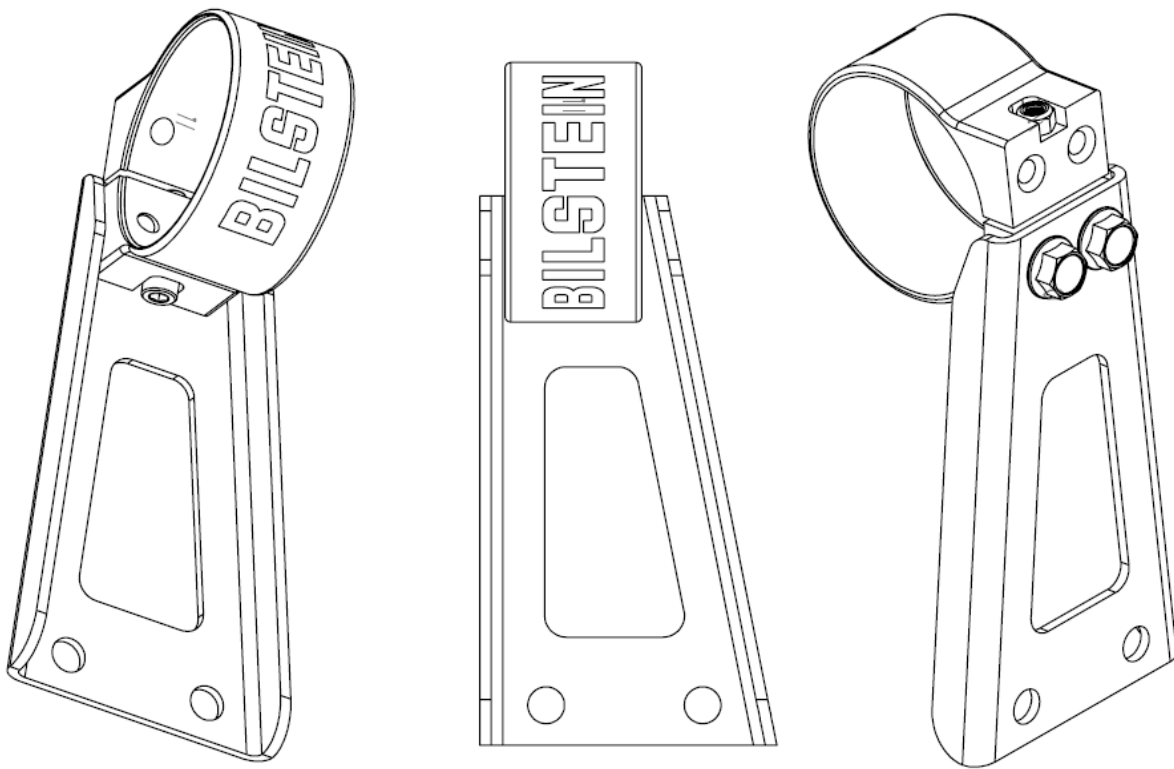

# E-WM05-0000116 MOUNTING INSTRUCTION



R. Slide reservoir clamp (with support plate attached) over the reservoir in the direction shown in the image below.



# E-WM05-0000116 MOUNTING INSTRUCTION



- S. Apply non-permanent thread locker on the end of each of the screw threads of the 4 supplied M10 Flange Head Cap Screws (BOM item #3). Then install the reservoir support plate assembly to the sway bar spacer as shown in the image below by placing these screws (2 per side) through the holes in the reservoir support plate and threading them into the threaded holes in the sway bar spacer with a 15mm socket.  
**Torque supplied M10 Flange Head Cap Screws to 37 ft-lb (50 Nm).**
- T. Slide the reservoir into the reservoir clamp until the clamp is right next to the decal as shown below.
- U. Tighten the Socket Head Cap Screw that was partially threaded in on Step Q with a 5mm hex key.  
**Torque Socket Head Cap Screw to 6 ft-lb (8 Nm).**



- V. Re-attach and torque outer tie rod, control arm to knuckle ball joint nut, and sway bar link according to service manual specifications.

### **ABS Line Relocation Bracket Installation**

- W. Clip and remove the OE zip tie shown in the image below (circle #1) and remove ABS line from bracket (circle #2). Be careful to not damage the ABS line during this process.



- X. Remove OE ABS line bracket by removing the hex head cap screw with a 10mm socket.
- Y. Install the ABS Line Relocation Bracket (BOM item #11 and #13) as shown below with the same hex head cap screw that was removed in the previous step. Secure ABS line with two zip ties (BOM item #12) as shown below. Trim excess zip tie length after installation.



**FRONT VIEW**



**BACK VIEW**

- Z. Once the ABS line has been relocated as shown above, the installation is complete.
- AA. Check wheel alignment and adjust to the vehicle manufacturer's specifications.

E-WM05-0000116  
MOUNTING INSTRUCTION



Final front right (passenger) B8 8112 shock installed on vehicle:



Aftermarket Bilstein upper control arm is pictured. The B8 8112 system will also work with OE upper control arms.

E-WM05-0000116  
MOUNTING INSTRUCTION



Final front left (driver) B8 8112 shock installed on vehicle:



Aftermarket Bilstein upper control arm is pictured. The B8 8112 system will also work with OE upper control arms.